



HEALTH AND SAFETY
AUTHORITY



**2020
Updated
Version**

Safe Quarry

Guidelines to the Safety, Health and Welfare at Work
(Quarries) Regulations 2008

(S.I. No. 28 of 2008) as amended

Our Vision: Healthy, safe and productive lives and enterprises



Published in April 2020 by the Health and Safety Authority.

© All rights reserved. No part of this publication may be reproduced, stored in a retrieval system, or transmitted in any form or by any means, electronic, mechanical, photocopying, recording or otherwise, without the prior permission of the Health and Safety Authority.

Acknowledgments



These Guidelines on the Safety, Health and Welfare at Work (Quarries) Regulations 2008 were developed with the assistance and advice of a Working Group on Quarrying Safety, representative of a wide range of interests in the quarrying industry.

The Health and Safety Authority wishes to express its grateful appreciation to the members of the Group.

The Authority also wishes to record its appreciation to the Mineral Engineering Department, Athlone Institute of Technology, for the assistance and facilities afforded the Group during its work.

Members of Working Group on Quarrying Safety

Mr Nigel Foley-Fisher (Chairman), Mineral Engineering Department, Athlone Institute of Technology

Mr Macarten McGroder and Mr Tommy Weir, Irish Mining and Quarrying Society (IMQS)

Mr Dermot Carey and Mr Justin Molloy, Construction Industry Federation (CIF)

Mr Paul Kelly, Irish Business and Employer's Federation (IBEC)

Mr Christy Cullen, The Services, Industrial, Professional and Technical Union (SIPTU)

Mr Reddy Morley, Mr Michael Keating and Mr Anthony Moran, Irish Concrete Federation (ICF)

Mr John Sheils, Institution of Engineers of Ireland (IEI)

Mr Stephen Harney, Mineral Engineering Department Athlone Institute of Technology

Mr Pat Griffin, Mr Manus Tiernan and Mr Jim Holmes, HSA Inspectors

Ms Aoife Guerin, HSA (Secretary)

This document was amended in 2020 by the Quarry Safety Partnership to take account of legislative amendments and current best practice

CONTENTS

Section	Title	Related Regulations	Page No
PART 1 INTERPRETATION AND GENERAL			
	INTRODUCTION	(Regulation 1)	8
1	WHAT IS A QUARRY?	(Regulation 3)	10
PART 2 SAFETY AND HEALTH MANAGEMENT			
2	APPOINTMENT OF OPERATOR	(Regulation 6)	12
3	OPERATOR TO BE APPOINTED BEFORE WORK COMMENCES	(Regulation 7)	13
4	NOTIFICATION TO AUTHORITY	(Regulation 8)	13
5	GENERAL DUTIES OF OPERATOR	(Regulation 9)	15
6	CONTRACTOR	(Sections 7 & 21 of 2005 Act)	16
7	MANAGEMENT STRUCTURE	(Regulation 10)	16
8	THE SAFETY STATEMENT	(Regulation 11)	18
9	CO-ORDINATED MEASURES	(Regulation 12)	20
10	SAFETY INDUCTION,COMPETENCE AND SKILLS CERTIFICATION	(Regulation 13)	20
11	INSTRUCTIONS, RULES AND OPERATING PROCEDURES	(Regulation 14)	21
12	PERMITS TO WORK	(Regulation 15)	22
13	DUTIES OF PERSONS AT WORK	(Regulation 16)	23
14	CONSULTATION	(Regulation 17)	24
15	RECORD KEEPING	(Regulation 18)	25
PART 3 GENERAL SAFETY PROVISIONS			
16	INSPECTION, MAINTENANCE AND TESTING	(Regulation 19)	26
16.1	IMMINENT RISKS		29
16.2	RECORDS OF INSPECTION AND MAINTENANCE		29
17	SAFETY EQUIPMENT	(Regulation 20)	32
18	BENCHES AND HAUL ROADS	(Regulation 21)	32
19	SAFEGUARDING EDGES OF EXCAVATIONS AND LAGOONS	(Regulation 22)	34
20	VEHICLES AND TRAFFIC RULES	(Regulation 23)	35
21	DANGER AREAS	(Regulation 24)	41
22	TRAFFIC ROUTES	(Regulation 25)	43
23	OUTDOOR WORK STATIONS	(Regulation 26)	44
24	PROTECTION FROM FALLING OBJECTS AND PROVISION OF SAFETY HELMETS	(Regulation 27)	45
25	PREVENTION OF DROWNING	(Regulation 28)	46
26	ESCAPE AND RESCUE FACILITIES	(Regulation 29)	47
27	SAFETY DRILLS	(Regulation 30)	48
28	FIRE AND EXPLOSION HAZARDS	(Regulation 31)	48
29	EXPLOSIVE OR HARMFUL ATMOSPHERES	(Regulation 32)	49
30	LIGHTING	(Regulation 33)	50
31	PREVENTION OF UNAUTHORISED ENTRY	(Regulation 34)	51

Section	Title	Related Regulations	Page No
PART 4 SAFETY PROVISIONS FOR ANCILLARY ACTIVITIES AND INSTALLATIONS			
32	APPLICATION OF THIS PART	(Regulation 35)	52
33	STABILITY AND SOLIDITY	(Regulation 36)	52
34	FLOORS,WALLS,AND CEILINGS AND OF ROOMS	(Regulation 37)	52
35	ROOM DIMENSIONS AND AIR SPACE IN ROOMS ETC	(Regulation 38)	54
36	WINDOWS AND SKYLIGHTS	(Regulation 39)	54
37	DOORS AND GATES	(Regulation 40)	55
38	VENTILATION	(Regulation 41)	56
39	TEMPERATURE IN ROOMS	(Regulation 42)	57
PART 5 EXPLOSIVES			
40	APPLICATION OF PART FIVE	(Regulation 43)	59
41	APPOINTMENTS OF EXPLOSIVE SUPERVISORS, SHOTFIRERS AND STOREKEEPERS	(Regulation 44)	59
41.1	EXPLOSIVES SUPERVISOR		60
41.2	APPOINTMENT OF SHOTFIRER		60
41.3	BLASTING CONTRACTORS		60
42	STORAGE,TRANSPORT, USE AND DISPOSAL OF EXPLOSIVES	(Regulation 45)	61
42.1	CUSTODY OF EXPLOSIVES		61
42.2	ON SITE SECURITY OF EXPLOSIVES		61
42.3	USE OF VEHICLES TO TRANSPORT EXPLOSIVES AT THE QUARRY		61
42.4	PROVISION AND MAINTENANCE OF EQUIPMENT		62
42.5	DISPOSAL OF SURPLUS AND DETERIORATED EXPLOSIVES		62
43	SHOTFIRING RULES	(Regulation 46)	63
44	BLASTING SPECIFICATION	(Regulations 47)	63
45	SHOTFIRING OPERATIONS	(Regulation 48)	65
46	DUTIES OF EXPLOSIVES SUPERVISOR AND SHOTFIRER	(Regulation 49)	65
47	MISFIRES	(Regulation 50)	67
48	PROHIBITED ACTIVITIES	(Regulation 51)	67
PART 6 SAFETY OF EXCAVATIONS (INCLUDING QUARRY FACES), TIPS AND LAGOONS			
49	INTRODUCTION		69
50	GENERAL DUTY TO ENSURE SAFETY OF EXCAVATIONS,TIPS AND LAGOONS	(Regulation 52)	69
50.1	DESIGN OF EXCAVATIONS,TIPS AND LAGOONS		69
50.2	WORKING EXCAVATIONS,TIPS,AND LAGOONS		71
51	OPERATING PROCEDURES FOR EXCAVATION,TIPS AND LAGOONS	(Regulation 53)	71
52	APPRAISAL AND SITE INVESTIGATION OF EXCAVATIONS, TIPS AND LAGOONS	(Regulation 54)	72
53	GEOTECHNICAL ASSESSMENT	(Regulation 55)	77
53.1	OPERATOR'S DUTIES IN RELATION TO EXCAVATIONS,TIPS AND LAGOONS WHICH ARE A SIGNIFICANT HAZARD		80

Contents cont'd

Section	Title	Related Regulations	Page No
53.2	OPERATORS DUTIES IN RELATION TO EXCAVATIONS, TIPS AND LAGOONS WHICH ARE NOT A SIGNIFICANT HAZARD		80
PART 7 AIR RECEIVERS			
54	APPLICATION	(Regulation 56)	81
55	SAFETY PRECAUTIONS	(Regulations 57)	81
56	MAINTENANCE AND EXAMINATION	(Regulation 58)	82
PART 8 GENERAL HEALTH HAZARDS			
57	HEALTH HAZARDS	(Regulation 59)	84
58	ATMOSPHERIC INFLUENCES	(Regulation 60)	84
59	DISPOSAL OF WASTE	(Regulation 61)	85
60	STATIONARY INTERNAL COMBUSTION ENGINES AND EXHAUST GASES	(Regulation 62)	85
61	HEALTH SURVEILLANCE	(Regulation 63)	85
PART 9 WELFARE			
62	SHELTERS AND ACCOMMODATION FOR CLOTHING AND FOR TAKING MEALS	(Regulation 64)	87
63	CHANGING ROOMS AND LOCKERS	(Regulation 65)	88
64	WASHING FACILITIES	(Regulation 66)	88
65	SANITARY CONVENIENCES	(Regulation 67)	89
66	SAFE ACCESS TO PLACES WHERE FACILITIES ARE PROVIDED	(Regulation 68)	90
67	PREGNANT WOMEN AND NURSING MOTHERS	(Regulation 69)	90
68	PERSONS WITH DISABILITIES	(Regulation 70)	90
69	REST ROOMS	(Regulation 71)	91
APPENDIX			
Appendix 1	Quarries Skills Certification Scheme Schedule 1		93
Appendix 2	Machinery subject to Regulation 23 (2) (e) Schedule 2		94
Appendix 3	Geotechnical Assessments Schedule 3		95
Appendix 4	Air Receivers Schedule 4		97
Appendix 5	Guidance Documents and Information Sheets		98
Illustrations & Photographs			
PART 2: SAFETY AND HEALTH MANAGEMENT			
Figure 1	Notification of Commencement or Abandonment of Quarrying Operations or Change of Operator		14
Figure 2	Sample management structure		18
PART 3: GENERAL SAFETY PROVISIONS			
Figure 3	Sample daily inspection record for a quarry		28
Figure 4	Crushed by Face Collapse		29
Figure 5	Sample inspection form for periodic inspection		30
Figure 6	Recommended haul road width (single vehicle)		32

ILLUSTRATIONS, DIAGRAMS & TABLES

Section	Title	Related Regulations	Page No
PART 3: GENERAL SAFETY PROVISIONS			
Figure 7	Recommended haul road width (two-way traffic)		32
Figure 8	Grade as a percentage		33
Figure 9	Grade as an angle		33
Figure 10	Comparison percent v degrees		33
Figure 11	Excessive gradients		33
Figure 12	Vehicle over running an edge		34
Figure 13	Edge protection less than 1.5 metres or the radius of the largest vehicle		34
Figure 14	Boulders or blocks of stone used as edge protection that can be easily pushed aside.		35
Figure 15	Consolidated bank of material large enough to absorb a vehicles momentum		35
Figure 16	Rocks with heapings of scalplings between and behind the rocks		35
Figure 17	Responsibilities for ensuring safe operation of vehicles		36
Figure 18	Unsafe tipping point		36
Figure 19	Safe tipping point		36
Figure 20	Excavator with falling object protection provided		37
Figure 21	Improved all round visibility provided by CCTV system		37
Figure 22	Photo montage of a large dumper truck fitted with CCTV and mirrors to improve visibility from the driving position		37
Figure 23	Two means of supporting a tipper body by CCTV system		38
Figure 24	Wheel handling equipment		39
Figure 25	Control measures for reversing operations		40
Figure 26	Overhead cable protection at a traffic route		41
Figure 27	Signage, bunding and rescue equipment at a sand & gravel lagoon		42
Figure 28	Face Edge Bunding system in Operation		42
Figure 29	Installing quarry face edge protection		42
Figure 30	Installing quarry face edge protection		42
Figure 31	Customer collection area		44
Figure 32	Warning signs		46
Figure 33	Operating a quarry using artificial lighting		51
Figure 34	Protecting the boundary of a quarry from inadvertent access		51
PART 5: EXPLOSIVES			
Figure 35	Survey instruments		60
Figure 36	Damage caused by Fly-rock		64
Figure 37	Drilled face		66
PART 6: SAFETY OF EXCAVATIONS (INCLUDING QUARRY FACES), TIPS AND LAGOONS			
Figure 38	Horizontally bedded strata		70
Figure 39	Steeply dipping strata		70
Figure 40	Flowchart of the appraisal & assessments of excavations, tips and lagoons		74
Figure 41	Significant Hazard – loose blocks above working area		75
Figure 42	Significant Hazard – unstable stockpile recovery face		75
Figure 43	Criteria for significant hazards		76
Figure 44	Illustration of the terms 'overall face angle', 'individual face', 'toe' and 'crest'		77
Figure 45	Tables of provision of sanitary facilities		91

Regulation 1*Citation and commencement.*

1. (1) *These Regulations may be cited as the Safety, Health and Welfare at Work (Quarries) Regulations 2008.*
- (2) *Subject to paragraph (3), these Regulations shall come into operation on 1 May 2008.*
- (3) *Regulations 13(c) and 16(b) shall come into operation on 1 November 2009.*

Introduction

These Quarry Regulations 2008 are made under the Safety, Health and Welfare at Work Act, 2005 and came into effect on the 1st May 2008. These regulations apply to all quarries. Throughout this guidance document the text of the regulations and schedules is in italic type, as above, and followed by brief non-exhaustive guidance.

Following this guidance is not compulsory and operators are free to establish and follow other equal or higher standards. However, if you do follow this guidance you will normally be doing enough to comply fully with the quarries regulations.

Other health and safety legislation apply to work at quarries such as many parts of the General Application Regulations 2007, Construction Regulations, Chemicals Regulations, etc. and must be applied as and when applicable. Further guidance is available from the Health and Safety Authority on those regulations. www.hsa.ie

Regulation 2*Interpretation.*

2. (1) *In these Regulations -*
“Act” means the Safety, Health and Welfare at Work Act 2005 (No.10 of 2005);
“appoint”, in relation to a person, means appoint in writing with a written statement summarising his or her responsibilities and duties;
“blast specification” means a blast specification prepared under Regulation 47;
“detonator” means an initiator for explosives that contains a charge of high explosive fired by means of a flame, spark, electric current or shock tube;

“excavation” means any place at a quarry where minerals are being or have been extracted and includes the ground, faces or sides of that place and any other incline;
“exploder” means a device designed for firing detonators;

“explosives” means Class 1 explosives as classified in the manual published by the United Nations Organisation and entitled “Fifteenth Revised Edition of the Recommendations prepared by the United Nations Committee of Experts on the Transport of Dangerous Goods” (ISBN 92-1-139120-6) or a later edition thereof that is in substitution for, and not an alternative to, that edition;

“explosive substance” means a solid or liquid substance (or a mixture of those substances) that is, by itself, capable by chemical reaction of producing gas at such temperature, pressure and speed as could cause damage to its surroundings;

“explosives store” means any of the following:

- (a) *a magazine licensed under sections 6 to 8 of the Explosives Act 1875,*
- (b) *a store licensed under section 15 of that Act,*
- (c) *premises registered in accordance with section 21 of that Act;*

“explosives supervisor” means a person appointed under Regulation 44 to organise and supervise all work involving explosives;

“geotechnical specialist” means a professional engineer or professional geologist competent to carry out a geotechnical assessment under Part 6;

“lagoon” means any natural or artificial pond (including any water-filled excavation) used in connection with quarrying operations and includes -

- (a) *such a pond that treats waste water utilising sunlight, bacterial action and oxygen to purify that water, and*
- (b) *a place at a quarry where waste water, sludge and liquid waste accumulate or are stored;*

“minerals” means any natural deposit, including stone, slate, clay, gravel and sand, and includes products of minerals, but does not include petroleum within the meaning of Part II of the Petroleum and Other Minerals Development Act 1960 (No.7 of 1960) or peat;

"Member State" has the meaning assigned to it in the Professional Qualifications Regulations;

"misfire" means an occurrence in relation to the firing of shots where -

(a) testing before firing reveals broken continuity that cannot be rectified, or

(b) a shot or any part of a shot fails to explode when an attempt is made to fire it;

"operator", in relation to a quarry, means an employer or other person who has been appointed under Regulation 6 by a quarry owner;

"preparation for sale" includes the crushing, screening, washing, drying and bagging of minerals;

"Professional Qualifications Regulations" means the European Union (Recognition of Professional Qualifications) Regulations 2017 (S.I. No. 8 of 2017);"

"prospecting" means the activity of searching for minerals or mineral deposits;

"public road" means a road over which a public right of way exists and the responsibility for the maintenance of which lies on a local authority within the meaning of the Local Government Act 2001 (No. 37 of 2001);

"QQI" means Quality and Qualifications Ireland;,"

"quarry" has the meaning given to it by Regulation 3;

"quarry manager" means an individual appointed under Regulation 10 to manage the operation of a quarry;

"quarry owner" means the owner of a quarry, or part of a quarry;

"registration card" means a quarries skills registration card issued by SOLAS pursuant to paragraph (3) and Schedule 1 under the Quarries Skills Certification Scheme;

"safety fuse" means a cord that contains an internal burning medium by which fire is conveyed at a continuous and uniform rate for the purpose of firing detonators or blackpowder, without initiating burning in a similar fuse that may be in lateral contact alongside;

"shot" means a single shot or a series of shots fired as part of one blast;

"shotfirer" means a person appointed under Regulation 44 to be responsible for shotfiring operations;

"shotfiring operations" includes any of the following:

(a) checking to ensure that the blast specification is still appropriate for the site conditions at the time the blasting is to take place,

(b) checking the geometry of shotholes,

(c) mixing explosives,

(d) priming a cartridge,

(e) charging and stemming a shothole,

(f) linking or connecting a series of shots,

(g) withdrawal and sheltering of persons,

(h) inspecting and testing a shotfiring circuit,

(i) firing a shot,

(j) checking for misfires,

(k) destroying surplus explosives;

"shotfiring rules" means rules made under Regulation 46;

"SOLAS" means An tSeirbhís Oideachais Leanúnaigh agus Scileanna

"storekeeper" means a person appointed under Regulation 44 to be responsible for the safe operation of an explosives store;

"tip" means an accumulation or deposit of minerals used in connection with quarrying operations and includes -

(a) overburden dumps, backfills, spoil heaps, stock piles and any wall or structure that retains or confines a tip, and

(b) a tip that had been used during previous quarrying or mining operations and from which minerals are being extracted for further use or for sale;

"trainee shotfirer" means a person appointed under Regulation 44 for the purpose of undergoing training in shotfiring operations under the close personal supervision of a shotfirer;

"vehicle and traffic rules" means rules made under Regulation 23;

"workstation" means any location at a quarry where work or work-related activities are undertaken.

(2) Where, under these Regulations, a person is required to make instructions, rules, operating procedures or schemes, such instructions, rules, operating procedures or schemes, as the case may be, shall be set out in writing and reasonable in the context of duty that the person is required to carry out.

(3) Taking account of the Professional Qualifications Regulations, SOLAS is responsible for the issue of valid registration cards, with photographic identification, under Schedule 1 and for the maintenance of a register of the cards issued.

The above establish many new definitions within the quarry regulations which are essential to the interpretation and meaning of the regulations.

1. WHAT IS A QUARRY?**(Regulation 3)****Meaning of "quarry"**

3. (1) In these Regulations "quarry" means, subject to paragraph (2), an excavation or system of excavations for the purpose of, or in connection with, the surface extraction of, or prospecting for, minerals and includes any of the following:
- (a) so much of the area (including works thereon and ancillary surface installations such as buildings and other premises and structures providing accommodation, rest and sanitary facilities) adjacent to or surrounding quarrying operations as is occupied for the purpose of, or used in connection with -
 - (i) those operations,
 - (ii) the storage or preparation for sale of the minerals extracted from the quarry, or
 - (iii) the removal from the quarry of any substance extracted from the quarry;
 - (b) a tip;
 - (c) a lagoon;
 - (d) a reclamation site -
 - (i) from which materials are being extracted for further use or for sale, and
 - (ii) where that extraction forms part of the process whereby that site is restored for agricultural, industrial, leisure or domestic use;
 - (e) a railway line or siding at the quarry.
- (2) Notwithstanding paragraph (1), "quarry" does not include any of the following:
- (a) a mine within the meaning of section 3 of the Mines and Quarries Act 1965 (No. 7 of 1965);
 - (b) a place where any of the following operations are carried out:
 - (i) extraction of minerals through drilling by boreholes,
 - (ii) prospecting with a view to such extraction,
 - (iii) preparation for sale of such extracted materials;
 - (c) an excavation or system of excavations made in the carrying out of construction work within the meaning of the Safety, Health and Welfare at Work (Construction) Regulations 2013 (S.I. No. 291 of 2013);

- (d) a public road;
- (e) an area of a quarry at which any manufacturing process (including the processing of minerals) is carried out;
- (f) an area of a quarry that is being used exclusively for a work activity unconnected with the extraction of minerals, or the preparation for sale of minerals.

A quarry is an excavation or series of excavations made for the purpose of, or in connection with, the surface extraction of minerals (whether in their natural state or in solution) or products of minerals.

A quarry includes:

- ▶ All the surface mineral workings and excavations;
- ▶ Tips (even if they are outside the site boundary);
- ▶ Storage of minerals (including stockpiles);
- ▶ Lagoons (natural or man made);
- ▶ Areas used for preparation of extracted minerals for sale (this includes crushing, screening, washing, drying, bagging and loading areas);
- ▶ Quarry roadways and railways;
- ▶ Buildings and structures at the quarry used for the working of the quarry; and
- ▶ Any reclamation site or disused tips (where the minerals are being extracted for sale or further use).

The activities covered are:

- (a) Preparation for the extraction of minerals;
- (b) Work activities where mineral extraction or preparation takes place;
- (c) Work to prevent water or other material flowing into an adjacent quarry; (even after quarrying has finished); and
- (d) Abandonment of a quarry including reclamation and landscaping work.

A quarry does not include an excavation or system of excavations made for the purpose of, or in connection with, the extraction of such minerals or products of minerals where the exclusive purpose of that extraction is to enable the minerals or products of minerals so extracted to be used for the purpose of carrying out any building work, civil engineering or engineering construction work on the site at which the extraction has taken place. However borrow pits

outside the area where construction will take place are covered by these quarry regulations.

A quarry does not include a mine; a public road; or a railway line. Also a quarry does not include prospecting, extraction or preparation for sale of minerals extracted by boreholes such as oil and gas.

Demarcation

Dividing a quarry into areas where the Quarries Regulations apply and other areas where they do not, may, in some cases, cause confusion. In such cases the operator may find it more convenient to treat the whole quarry site as being subject to the Quarries Regulations. Demarcation is at the discretion of the operator, however additional legal requirements may also be applicable to some activities and must be considered.

Areas that the operator deems that the Quarries Regulations do not apply should be clearly marked on a site plan and the plan should be included in the safety statement and arrangements for co-ordinating safety and health between the operator and the occupants of any excluded areas should be explained in the safety statement.

The Quarries Regulations apply to sites while minerals are extracted for a further use as part of another process, such as reclamation.

Rail lines operated by a railway company are not legally part of a quarry; however, any part of a railway system that a quarry operates itself forms part of the quarry.

Application

(Regulation 4)

- (1) Subject to paragraph (2), these Regulations apply to all quarries.
- (2) These Regulations do not apply to a quarry in relation to which -
 - (a) notice of permanent cessation of quarrying operations has been given to the Authority in accordance with Regulation 8, and
 - (b) all work relating and incidental to that cessation has been completed, including work for the purpose of preventing the escape from that quarry of water or other substance that flows when wet.
- (3) The relevant statutory provisions apply to all quarries, without prejudice to more stringent or specific provisions contained in these Regulations.

Amendment of Safety, Health and Welfare at Work (Extractive Industries) Regulations 1997.

(Regulation 5)

The Safety, Health and Welfare at Work (Extractive Industries) Regulations 1997 (S.I. No. 467 of 1997) are amended by inserting after Regulation 3 the following Regulation:

"Non-application to quarries

3A. Notwithstanding Regulations 2(1) and 3, these Regulations shall not apply to a quarry within the meaning of the Safety, Health and Welfare at Work (Quarries) Regulations 2008."



2. APPOINTMENT OF OPERATOR (Regulation 6)

6.

- (1) *Before the commencement of operations at a quarry, or part of a quarry -*
 - (a) *the quarry owner shall appoint a competent person who has sufficient resources to be the operator of the quarry, or part of the quarry, as the case may be, or*
 - (b) *where the quarry owner is competent and has sufficient resources to do so, he or she may appoint himself or herself as operator of the quarry, or part of the quarry and shall make a record of the appointment.*
- (2) *Where the quarry owner under paragraph (1)(a) appoints another person to be the operator of the quarry, or part of the quarry, both parties shall the record and the quarry owner shall provide a copy of the signed record to the operator.*
- (3) *The original record and a signed copy of it shall be kept by the quarry owner and the operator, respectively, for a period of 6 years from the termination of the operator's appointment as operator of the quarry, or part of the quarry.*
- (4) *The quarry owner shall provide the operator with any relevant information available to him or her, which might affect the safety, health and welfare of persons at work at the quarry.*
- (5) *Where the quarry owner appoints different operators for different parts of his or her quarry, he or she shall -*
 - (a) *appoint one of them to be the common operator for the purposes of Regulation 12, and*
 - (b) *demarkate the different parts of the quarry.*

The person entitled to work the quarry is the person who has legal ownership of the land where the quarry is to be worked. As they are the owners they have a legal duty in relation to the land and to how it is developed and any subsequent reclamation works upon completion of extraction work. In most cases this person (the owner) will also be the operator as described below but in some circumstances, where the land is leased out to an individual or a corporate body or the quarry is worked on behalf of the person entitled to work the quarry this would not be so.

Examples would be where a farmer leased a field to an individual or a corporate body to extract sand or where a landowner seeks to develop his or her land as a quarry but does not have the expertise or equipment to do so and he or she hires a contractor to work the quarry on his or her behalf.

Where the person entitled to work the quarry agrees that someone else will operate the quarry, he/she must be satisfied that the proposed operator has enough resources to enable the quarry to be worked safely, such as enough experienced and, where necessary, qualified staff. The agreement must be recorded in writing and both parties must keep a signed copy. In most cases of this type there will be a written contract setting out the agreement and this would form a suitable record. Both parties must keep signed copies of this agreement whilst it remains in force.

The person entitled to work the quarry must also pass to the operator any information relevant to working the quarry safely, for example, geological information, geotechnical reports, and details of previous mine or quarry workings and information about minerals or other materials deposited on site.

In a very small number of cases, such as where there is joint ownership of the land, there may be more than one person entitled to work the quarry. In such cases they should either reach agreement that there will be one operator in overall control, or the site should be clearly divided into clearly defined areas, each area being a separate quarry with its own operator.

3. OPERATOR TO BE APPOINTED BEFORE COMMENCEMENT OF QUARRYING OPERATIONS (Regulation 7)

7. *No person shall be deployed to carry out quarrying operations at a quarry unless an operator has been appointed under Regulation 6.*

This in effect means that no person should be required to carry out any quarrying related work prior to the written appointment of an operator who takes charge of all work activity at the quarry. This is aimed at ensuring that persons assigned work come under the control and responsibility of a competent operator.

The duties imposed on the operator do not relieve individual employers of their duty to comply with statutory duties. For example, a contractor at a quarry supplying and using vehicles for use by his or her employees at the quarry still has duties to provide and maintain safe plant and equipment and safe systems of work under Section 8 of the Safety, Health and Welfare at Work Act 2005. However, a contractor must also co-operate with the operator to ensure that the operator can carry out his or her statutory duties and observe the quarry rules and safe operating procedures.

4. NOTIFICATION TO AUTHORITY (Regulation 8)

- 8.
- (1) *The operator shall ensure that written notice in an approved form is given to the Authority not later than 14 days following the occurrence of any of the following events in respect of the quarry:*
- his or her appointment as operator;*
 - the commencement of quarrying operations;*
 - the permanent cessation of quarrying operations.*
- (2) *The quarry owner shall, not later than 14 days after the appointment of a common operator under Regulation 6(5), give written notice of that appointment in an approved form to the Authority.*

Notification must be sent to the Health and Safety Authority within 14 days of:

- ▶ The Appointment of an Operator (including a change in the name of the appointed operator or quarry)
- ▶ The Commencement of Quarry Operations (such operations to include putting in roads, clearing topsoil or building offices or workshops);
- ▶ The Permanent Cessation of Quarry Operations.

Notification should be posted to, e-mailed to wcu@hsa.ie or sent by fax to the Head Office of the Health and Safety Authority (A sample notification form is shown in figure 1.)

On opening a quarry notification must be in writing and must include:

- ▶ The name, address, telephone and fax number of the operator;
- ▶ The name and address of the quarry including Ordnance Survey grid references;
- ▶ The telephone and fax number of the quarry;
- ▶ A brief description of the quarry and the mineral to be extracted; and
- ▶ The date when extraction of minerals is to start/finish.

In addition to notifying the Health and Safety Authority when the name of the quarry changes, operators should also notify the utility companies of any changes. Delays have occurred during emergencies when the power to a quarry needed to be isolated, but the name for the quarry used by the quarry personnel and the electricity supplier was different from that notified.

When a quarry closes, any remaining excavations or tips must be left in a safe condition. In the case of abandoned tips, the notification needs to include the information gathered through geotechnical assessments.

Safety, Health and Welfare at Work (Quarries) Regulations 2008

Figure 1: Notification of Commencement or Abandonment of Quarrying Operations or Change of Operator

Regulation 8	NOTIFICATION OF APPOINTMENT OR CHANGE OF OPERATOR OR COMMENCEMENT OR PERMANENT CESSATION OF QUARRYING OPERATIONS
I hereby give notice of (delete as appropriate)	Appointment/Change of Operator Commencement of Quarrying Operations Permanent Cessation of Quarrying Operations
Name of Person or Company under which the business is carried on	_____
Name of Operator	_____
Signature of or on behalf of Operator	_____
Date	_____
Address	_____ _____
Telephone Number:	_____ Fax Number: _____
Email Address	_____
Name of Quarry	_____
Place where Quarry is situated	_____ _____
State townland and	_____
Nearest Post town and	_____
Ordnance Survey Grid References:	_____
Date when operations are to Commence/Cease	_____
or	
Change of Operator is to take affect	_____

5. GENERAL DUTIES OF OPERATOR (Regulation 9)

9.

(1) The operator shall, so far as is reasonably practicable, ensure that -

- (a) the quarry and any machinery, tool or other article used at work there are, as appropriate, selected, designed, constructed, installed, equipped, commissioned, protected, operated and maintained in such a way that persons at work can perform the work assigned to them without endangering the safety, health and welfare of themselves or others,
- (b) if any of the articles referred to in subparagraph (a) is located in an area of the quarry within which risk of fire or explosion from ignition of gas, vapour or volatile liquid exists, or is likely to exist, that article is -
 - (i) suitable for use in that particular area, and
 - (ii) if necessary, fitted with suitable protective devices and fail-safe systems,
- (c) mechanical equipment and plant at the quarry is of adequate strength and free from patent defect and suitable for the purpose for which it is intended, and
- (d) electrical equipment and plant at the quarry is of sufficient capacity for the purpose for which it is intended.

(2) The operator shall ensure, as regards that quarry, that -

- (a) work is planned taking into account the elements of the safety statement that concern the risks of falls, movements or slips of ground and, in particular, that -
 - (i) the height and slope of overburden

stripping and extraction faces is appropriate to the nature and stability of the ground and the methods of working,

- (ii) benches and haul roads are stable enough for the plant used and are constructed and maintained in such a way that plant can be moved safely,
- (iii) before the start or restart of work, stripping and extraction faces above work areas or haul roads are checked for loose ground or rocks and scaling is carried out where necessary, and
- (iv) faces and tips are not worked in such a way that instability is created,
- (b) it is organised so as -
 - (i) to provide adequate protection against hazards,
 - (ii) to be kept in good order, with any hazardous substances or deposits removed, and
 - (iii) not to endanger the safety and health of persons at work,
- (c) workstations are designed and constructed according to ergonomic principles taking into account the need for persons at work to carry out their work safely and without risk to health at their workstations,
- (d) a sufficient number of persons with the requisite competence to perform the tasks assigned to them are present,
- (e) where a workstation is occupied by a person on his or her own, the necessary supervision or means of communication is provided, and
- (f) in the event of the permanent cessation of quarrying operations there, the quarry is left, so far as is reasonably practicable, in a safe condition.

² "Competent person" is defined in Section 2(2) of the Safety, Health and Welfare at Work Act 2005 as follows -

"(2) (a) For the purposes of the relevant statutory provisions, a person is deemed to be a competent person where, having regard to the task he or she is required to perform and taking account of the size or hazards (or both of them) of the undertaking or establishment in which he or she undertakes work, the person possesses sufficient training, experience and knowledge appropriate to the nature of the work to be undertaken.

(b) Account shall be taken, as appropriate, for the purposes of paragraph (a) of the framework of qualifications referred to in the Qualifications (Education and Training) Act 1999."

The operator is in overall control of the quarry. Most of the statutory duties fall on the operator.

As outlined in Section 2 (the owner) the person entitled to work the quarry, if competent, could and, in the majority of cases, would be the operator. In any other circumstances, he or she must appoint the operator, normally a company, in writing.

There can only be one operator for each quarry, and it is very important that this role is clearly allocated.

If there are several employers who could be the operator, or it is not clear which of them is in overall control, then they must agree among themselves who will take overall control, or divide the excavation into several quarries, each with its own operator.

It is important that everybody who works at a quarry knows who the operator is, who manages the quarry and how he or she can be contacted. This can be achieved by displaying a notice at a suitable place at the quarry setting out the operator's name, the management structure and relevant addresses and telephone numbers.

The quarry operator manages the safety and health of all operations to ensure that risks are properly controlled in a pro-active and co-ordinated manner.

The operator has overall responsibility for planning, co-ordinating and overseeing all work at the quarry, including the work of contractors. The operator must ensure that contractors have correctly identified hazards and control measures by carrying out risk assessments.

The operator is responsible for any buildings and structures at the quarry even if they are temporary.

The operator is responsible for ensuring that the quarry is left in a safe condition following permanent cessation of quarrying activities or abandonment.

The proper planning of a quarry will not eliminate all safety and health risks, but it can make a major contribution, with priority being given to measures that safeguard the maximum number of people.

6. CONTRACTORS

(See Sections 7 & 21 of the Safety, Health and Welfare at Work Act 2005)

Irrespective of the duties of the operator each contractor at a quarry remains responsible for complying with relevant safety and health legislation. Contractors may also be legally liable if, by their acts or omissions, they cause the operator to commit an offence. For the purpose of this guidance a contractor can be an employer and/or a self-employed person.

The Health and Safety Authority have prepared guidance entitled **Client and Contractor Code of Conduct at Quarrying Locations** which is copied in Appendix 5 of this document

7. MANAGEMENT STRUCTURE (Regulation 10)

10.

- (1) *The operator shall establish a management structure that includes the appointment of -*
 - (a) *a competent individual as quarry manager to -*
 - (i) *manage the operation of the quarry at all times when persons are working in the quarry, provided that where the operator is an individual and is competent he or she may appoint himself or herself,*
 - (ii) *advise the operator as to the observance of the requirements of the relevant statutory provisions, and*
 - (iii) *exercise a general supervision of the observance of those requirements and the promotion of the safe conduct of work generally,*
 - (b) *persons appointed under Regulation 44, and*
 - (c) *an adequate number of competent persons -*
 - (i) *to enable the quarry to be operated and managed safely and in accordance with the safety statement,*
 - (ii) *to supervise persons at the quarry engaged in work activities involving serious risk to safety and health as identified in the safety statement, and*
 - (iii) *to visit occupied workstations at the quarry at least once during each shift, where this is specified as necessary under the safety statement.*
- (2) *The operator shall ensure that the management structure is reviewed regularly and revised where necessary and, in particular, if the quarry undergoes significant changes (including natural changes), extensions or conversions.*
- (3) *The operator shall ensure that each person who forms part of the management structure is provided with a copy of those parts of the safety statement that describe that person's authority and duties.*

The operator must set up a management structure that ensures that there are a sufficient number of competent people to manage the quarry safely. This structure and the competencies required should meet

the needs identified during the risk assessments and planning activities already referred to. It must also include any sub-contractors who have significant roles in the management of the quarry. The management structure must be set out in writing and included in the safety statement.

A competent person must be appointed as quarry manager to manage the operation of the quarry at all times when work is being undertaken. If the operator is a competent individual he or she could also be the quarry manager. There is no requirement to notify the Authority of the appointment of the quarry manager. Arrangements should be in place for cover during absences of the quarry manager and other key personnel, for example, during sick leave, holiday leave etc. Everyone working at the quarry needs to know who the manager is. The quarry manager is the operator's representative at the quarry and it is his or her role to advise and assist the operator to fulfil all legal requirements. The appointment of a quarry manager does not take away the legal duty of the operator to fulfil his or her statutory functions but provides for a point of contact to the contractors, self-employed persons at the quarry and the operator's employees. The quarry manager and other persons in the management structure can be held accountable for their acts or omissions, or any offence committed with their consent, connivance or neglect under the Safety, Health and Welfare at Work Act 2005 (See Sections 80 & 81 of that Act).

The entire workforce needs to understand their responsibilities and authority in relation to safety and health. They also need to know how their responsibilities interrelate with those of others. It is normally best if the key responsibilities are summarised in the management structure with more detail being provided in the individual job descriptions.

It is particularly important that managers and supervisors properly understand their safety and health responsibilities and authority. They must also be competent to do their job so that others are not put at risk. The type and degree of competence will vary from quarry to quarry and from job to job. In some cases particular qualifications are needed, for example, where explosives are used.

The management structure should include any senior managers off-site who are responsible for safety and health, as well as managers and supervisors working at the quarry. Where the operator is also the quarry manager, then the management structure may be very simple. In other companies the structure may be more complex, but the structure should always make it clear where responsibilities lie.

The management structure must be reviewed routinely and, in particular, where the work or people change significantly, to ensure that it remains appropriate. Operators need to inform the workforce about the management structure. The legal responsibility for the overall control of the quarry rests on the operator and not on an individual manager or supervisor appointed to take charge on site – unless that individual is the operator.

A sample management structure for a reasonably large quarry operation is shown overleaf in Figure 2 "*Sample management structure*".

Figure 2: Sample management structure

HSA STONE PRODUCTS LIMITED ORGANISATION CHART FOR QUARRY

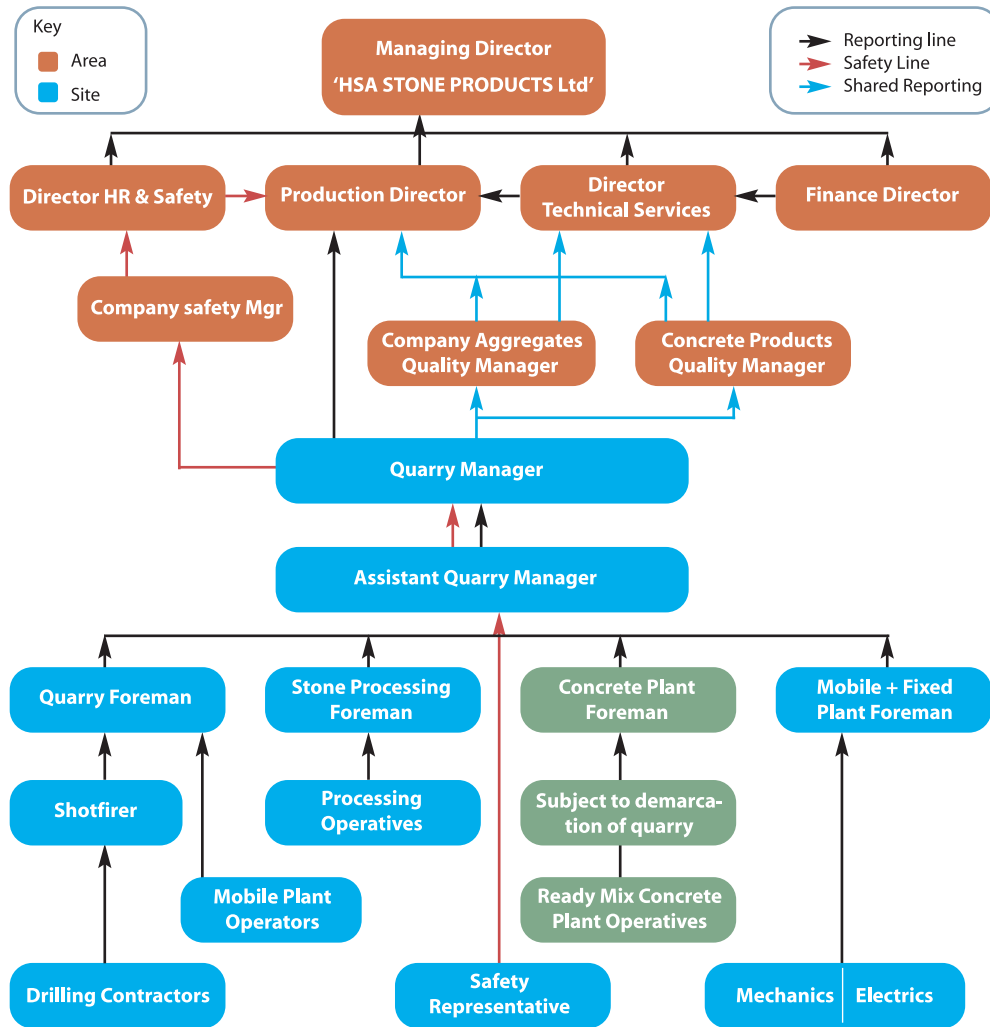

8. SAFETY STATEMENT (Regulation 11)

- 11.
- (1) The operator shall ensure that the safety statement, prepared in compliance with section 20 of the Act, includes details of the -
- (a) management structure referred to in Regulation 10 setting out the duties and responsibilities of each person in the management structure,
 - (b) operating procedures and instructions required by Regulation 14(a), relating to the safety and health of persons at work at the quarry in both normal and critical situations there,

- (c) arrangements for the review of safety measures in accordance with section 20 of the Act,
- (d) system of permits to work, if required by Regulation 15,
- (e) inspection, maintenance and testing schemes prepared in accordance with Regulation 19,
- (f) vehicles and traffic rules required by Regulation 23,
- (g) instructions required by Regulation 29(c),
- (h) precautions taken to protect against, detect and combat the outbreak and spread of fire required by Regulation 31,

- (i) *arrangements made and the equipment and measures necessary to prevent explosions required by Regulation 31,*
 - (j) *shotfiring rules made under Regulation 46,*
 - (k) *operating procedures for excavations, tips and lagoons required by Regulation 53,*
 - (l) *conclusions of any appraisal, site investigation or geotechnical assessment of an excavation, tip or lagoon undertaken pursuant to Regulations 54 and 55, and*
 - (m) *arrangements for health surveillance required by Regulation 63.*
- (2) *In addition to the matters referred to in paragraph (1), the safety statement shall, where appropriate, also include -*
- (a) *a plan detailing the equipment and measures required to protect persons at work at the quarry from the risk of explosion or fire in compliance with Regulations 31 and 32(1),*
 - (b) *where toxic gases are or may be present in the atmosphere at the quarry in such concentration that the atmosphere may be harmful to the health of persons at work, a plan detailing the protective equipment and measures required to protect persons at work at the quarry from the harmful atmosphere in compliance with Regulation 32(2), and*
 - (c) *a diagram of the quarry indicating those areas to which these Regulations do not apply by virtue of Regulation 3(2).*

All quarries are required to have in place a site specific safety statement by virtue of Section 20 of the Safety, Health and Welfare at Work Act 2005, based on an identification of hazards and a written risk assessment prepared in accordance with Section 19 of the Act. The basic purpose of the safety statement is to set out how the safety, health and welfare of the employees will be secured and managed at the quarry.

The safety statement should be communicated appropriately so that all those on whom it places responsibility understand their duties.

The safety statement should be reviewed to ensure it meets all requirements. It should be drawn up before the work starts, and in the case of a new quarry at the design stage. It should be continuously developed

to keep it up to date as more is learned about the geology of the site, or as management systems or working methods change.

To be of use the safety statement must be a working document providing practical information to people at the quarry about safety and health measures and their role in implementing them. Consultation processes and the involvement of the workforce are needed to produce an effective document.

In some cases the safety statement will not be a single document, but a collection of documents. Existing material does not need to be re-written as long as all of the requirements are addressed, and the composite document is properly cross-referenced and indexed.

The document must set out a management structure and explain each person's authority and the duties of those in that structure. This needs to include relevant off-site staff such as area managers, geologists, engineers and surveyors. Where managerial responsibilities are given to sub-contracted staff they must also be included in the structure.

The level of detail recorded should be in proportion to the degree of risk and complexity of the operations. Some quarries probably only need simple documentation, while large quarries are likely to need something more detailed.

The document must contain enough information to demonstrate that the risks have been properly assessed and that adequate measures have been taken to safeguard the safety and health of people at work at the quarry and others that might be affected under normal and abnormal conditions.

Operators must ensure that all the measures specified in the safety statement are taken and that any plans are followed in practice. This involves putting in place appropriate monitoring arrangements.

A copy of the safety statement should be held on site and must be available to every employer and all who work at the quarry, so that they can understand the risks and the control measures relating to their work. A copy of the whole document need not be given to everybody, but everyone needs to have copies of those parts that may affect him or her and with which they have to comply.

The safety statement needs to address how information is communicated to, and how the impact of quarrying operations upon the public,

such as those living in neighbouring properties, is minimised. It should set out procedures for items such as the notification of blasts, instruction to drivers on respecting speed limits on roads close to the quarry entrance. It is unnecessary to bring the contents of the safety statement to the attention of the public but keeping people informed will assist in maintaining good relations with neighbours.

9. CO-ORDINATED MEASURES (Regulation 12)

12. Without prejudice to section 21 of the Act, where an operator has been appointed under Regulation 6(1) or where a common operator has been appointed under Regulation 6(5), that operator or common operator shall co-ordinate the implementation of all measures relating to the safety, health and welfare of persons at work at the quarry.

This regulation should be considered by all operators and common operators. In many quarries some of the work is carried out by contractors, such contractors may be large or small companies or self-employed individuals.

Section 21 of the Safety, Health and Welfare at Work Act 2005 requires every employer and self-employed person involved in sharing a place of work with another employer or self-employed person to co-operate in implementing any safety, health, welfare and occupational hygiene provisions considered necessary. Every employer and self-employed person must extend this co-operation to the operator of the quarry.

Section 12 of the Safety, Health and Welfare at Work Act 2005 extends the duty of care on all employers and self-employed persons to carry out their undertaking in such a way as to ensure that persons not in their employment are not exposed to risks to their safety and health.

Good co-operation and co-ordination is crucial to ensuring safety and health and for the operator to fulfil his or her duties to:

- ▶ compile a safety statement;
- ▶ manage the quarry in a co-ordinated way which ensures safety and health; and
- ▶ ensure that the safety and health arrangements described in the safety statement work in practice.

The development of the safety statement and its effective implementation depend on the flow of information and co-operation between the operator, the contractors and the workforce.

Contractors are required to notify the Health and Safety Authority of any injuries or dangerous occurrences that are reportable under the Safety, Health and Welfare (General Application) Regulations 2007 as amended in 2016 and they should also bring any such notification to the attention of the operator.

10. SAFETY INDUCTION, COMPETENCE AND SKILLS CERTIFICATION (Regulation 13)

13. The operator shall ensure that no person shall undertake any quarrying operations unless that person -

- (a) has received appropriate site-specific safety induction instruction,
- (b) is either competent to do that work, or does it under the instruction and supervision of some other person who is competent to give instruction in, and supervise the doing of, that work for the purpose of training that person, and
- (c) if engaged in any of the tasks specified in Schedule 1, has been issued with and is in possession of a current registration card in respect of the Quarries Skills Certification Scheme

Everyone working at a quarry must be competent for the work they are required to do. They, and their managers, need to know the limits of their competence.

Suitable site specific induction arrangements need to be made for all recruits who are new to a site; this is particularly important for young persons and those who are new to the industry including non-Irish nationals who may be unfamiliar with Irish quarry work practices and safety signage.

This induction training needs to cover all matters and be site-specific. This includes relevant aspects of the safety statement, outcome of risk assessments, the arrangements for first aid, fire, evacuation and blasting procedures. Further training is likely to be needed whenever:

- (a) someone takes on substantial new responsibilities; or

- (b) there is a significant change in work equipment or systems of work.

A person's competence will decline if skills are not used regularly. Training may, therefore, need to be repeated periodically to ensure continued competence in the skills that are not often used. Information from personal performance, safety and health monitoring, accident investigation and near-miss incidents can help identify a need for additional training.

People working at a quarry must not undertake any work for which they are not competent – except under the careful instruction and supervision of a competent instructor or supervisor. Operators of equipment and mobile plant as listed in Schedule 1, such as loading shovel drivers, or crane operators etc, must receive accredited training as detailed in the Schedule and a copy of the relevant certificate or registration card should be held at the quarry.

A person shall be deemed to be competent where, having regard to the task he or she is required to perform and taking account either of the size or the hazards, or both, of the undertaking or establishment in which he or she undertakes work, he or she possesses sufficient training, experience and knowledge appropriate to the nature of the work to be undertaken.

In short, competency is the ability to apply knowledge, understanding, practical and thinking skills to achieve efficient and safe performance to the standards required in employment. This includes solving problems and being sufficiently flexible and skilled to meet changing demands.

Everyone who works at a quarry must be properly trained and have appropriate experience and knowledge to enable them to do their work safely. A few will need other qualities such as management or interpersonal skills, or formal qualifications, for example, geotechnical specialists, shotfirers and explosives supervisors. Management training must, where appropriate, include training in safety management, risk assessment and developing and using safe systems of work.

The risk assessments and occupational standards should help to determine the safety and health competencies for particular jobs. By comparing the competencies needed against those that people already have, managers can determine what additional skills are required, and how these can be

achieved, for example, through training and coaching. Care should be taken when using existing workers for training. Such training can be useful, but may also lead to bad practices and attitudes being passed on to a new generation of workers, for example, concerning the use of personal protective equipment. Safety and health training is an important way of developing competence and helps to encourage safe working practices. It can contribute positively to the safety and health culture, and is needed at all levels, including top management.

Safety representatives selected and appointed in accordance with Section 25 of the Safety, Health and Welfare at Work Act 2005 must be allowed reasonable time off from their duties to acquire knowledge and skills to discharge their functions adequately.

11. INSTRUCTIONS, RULES AND OPERATING PROCEDURES (Regulation 14)

14. *The operator shall -*

- (a) *ensure that suitable instructions and operating procedures are in place at the quarry with a view to securing the safe use of work equipment,*
- (b) *ensure that copies of all instructions, rules and operating procedures required to be made under these Regulations are kept at the quarry and given to any person at work at the quarry to whom they apply, and*
- (c) *take all reasonable measures to ensure that each person at work at the quarry understands the instructions, rules and operating procedures made under these Regulations that apply to that person.*

The operator is required to prepare instructions, rules and safe operating procedures. The aims of any rules or operating procedures are to ensure the safety and health of the quarry workforce and others that may be at risk. These rules should be prepared where there is a safety and health need, for example, those regarding the wearing of safety helmets, and the implementation of control measures based on risk assessment.

The Quarry Regulations explicitly require written rules such as those in relation to the use of vehicles, shotfiring operations, etc.

All rules need to be communicated to, and understood by, those who have need to enforce or follow them.

Safety and health measures need to be systematically and routinely monitored and reviewed to ensure they are working as intended. They may fail because people are unaware of them, are too busy to follow them, or don't consider them to be important. They may also fail because the measures are out of date or flawed. Such failings will only become evident if the measures are regularly reviewed and monitored. Action should be taken immediately to remedy any failings which have been identified and to ensure that everyone follows the safety and health requirements in future.

The arrangements for review need to address safety procedures and current practices, as well as physical safeguards. This helps to identify procedures and practices that are not effectively controlling a risk. For example, a machinery guard which is regularly left off may indicate a need to explain the risk, or to modify the guarding, the system of work or supervision, to ensure that the safe way of working is also the easiest.

The findings of any review should be used to update and revise the safety and health measures. This feedback loop ensures continued effectiveness and contributes to a progressive improvement in safety and health.

Reviews are likely to be required when equipment or working practices change significantly, when new technology is introduced and after accidents including 'near-misses'. Such incidents provide opportunities to identify weaknesses and change peoples' attitudes for the better. This opportunity should not be missed. But it is also important to identify the causes of an incident in any investigation. Learning from experience like this is known as reactive monitoring. Although this is very important, it is essential that there are also procedures for checking the systems and procedures are working without waiting for something to go wrong or an incident to occur. This is known as active monitoring.

The operator should advise those who work at the quarry of their duty to notify their manager, or some other designated person, of any shortcomings in the safety and health arrangements, even when no immediate danger exists. This provides valuable information which contributes to the review process.

12. PERMITS TO WORK (Regulation 15)

15. *The operator shall ensure that -*

- (a) *based on an assessment of the risks, a system of permits to work is introduced for the carrying out of -*
 - (i) *hazardous activities, and*
 - (ii) *activities which, when carried out in conjunction with other activities, may cause serious risks to the safety, health and welfare of persons at work, and*
- (b) *a permit to work referred to in paragraph (a) is issued by a competent person before the particular activity concerned commences and specifies the conditions to be fulfilled and protective measures to be taken before, during and after the carrying out of the activity.*

A safe system is required for all work activities, but particularly for hazardous maintenance activities. A large proportion of serious and fatal accidents occur during maintenance operations. A permit to work system is a formal procedure to ensure that the system of work is properly planned and implemented for jobs which have a significant risk. Permits are most often required for maintenance work where normal safeguards cannot be used, or where new hazards are introduced by the work. They should not generally be used for low-risk operations, as this tends to devalue the system.

A permit to work should not be confused with giving someone permission to work on site; nor is it an excuse to carry out a task without eliminating hazards or minimising risks. Issuing a permit does not, by itself, make a task safe. That can be achieved only by the diligence of those preparing, supervising and carrying out the work. The system does, however, provide a formal procedure to determine, systematically, what precautions are required, how this should be communicated, recorded and monitored and how work should be authorised.

In some high-risk situations, simple systems of work such as isolation or locking off procedures are sufficient by themselves to ensure safety. Such systems are generally appropriate when there is only a single source of risk, which can be eliminated by, for example, removing a fuse and locking off an electrical isolator switch. In more complicated cases, for example, where

there are several sources of risk or where the risk is more severe, such as with high voltage systems, or where complex procedures are needed before it is safe to start work, a permit to work is usually appropriate.

The aim of the permit to work system is to ensure that the task is carried out in accordance with the carefully considered conditions specified in a permit drawn up and independently verified by competent individuals. As well as setting out the steps which must be taken before and during the task, permits should state any conditions to be met after the work is completed, i.e., the procedure for handing back the plant or area in a safe condition for normal operations.

The Permit to Work System

Permits to work are required whenever there is a significant risk to safety and health during an operation, and where precise preparation of the site or plant and clear, unambiguous communications of procedures is needed to control the risk. A permit to work system should set out:

- (a) what work requires permits;
- (b) who is authorised to issue and accept permits, including any limitations to their authority;
- (c) how the safety of a proposed system of work and any risks it might create for others is checked (this may include cross referencing with other permits);
- (d) how information about the hazards and the work to be carried out is communicated;
- (e) the maximum time a permit may be valid;
- (f) hand-over arrangements if work involves more than one team, e.g. over a shift change;
- (g) the hand-back/suspension arrangements in cases where:
 - (i) the permit is found to be flawed or unsuitable – for example because assumptions upon which it was based are incorrect;
 - (ii) more time is needed to carry out the work than the permit allows;
- (h) arrangements for the display of the permit at the work site;
- (i) arrangements for hand-over on completion of work; and
- (j) arrangements for monitoring and revising the system and its operation.

Examples of work at a quarry that may require a permit include:

- ▶ entry into confined spaces or other high risk areas;
- ▶ entry into machinery where isolation or locking-off procedures are insufficient to ensure the safety of workers; and
- ▶ work on high voltage systems.

Issuing a Permit

Two people are responsible for each permit: the person issuing the permit (normally the manager responsible for the plant or location where the work is to be performed) and the person accepting it. These two people should independently consider the risks and precautions, as this substantially reduces the chance of overlooking important issues. Expert advice may also be required to identify the hazards and risks and to decide what precautions are required. Such experts must have sufficient experience and knowledge to carry out their tasks properly.

Communication and training

All staff involved with permits to work need to understand the hazards and the controls taken to reduce the risks. This cannot be achieved by simply giving everyone a copy of the permit. There needs to be appropriate formal briefing to ensure that everyone understands exactly what is required and why. The use of plans and diagrams may help with some work. Those involved also need to know when work covered by the permit begins and whether there are any time constraints.

Monitoring

Suitable arrangements for monitoring the operation of the permit to work system are essential. They typically involve testing a sample of permits to ensure that they are completely correct and that the precautions are appropriate to protect people from risk and that they were followed in practice.

13. DUTIES OF PERSONS AT WORK (Regulation 16)

16. Every person at work to which these Regulations apply shall -

- (a) comply with all applicable instructions and rules

- and operating procedures, and*
- (b) *show his or her registration card when requested by the person's employer, the operator, or if applicable, the common operator.*

This should be read in conjunction with Sections 13 and 14 of the Safety, Health and Welfare at Work Act 2005.

The Health and Safety Authority have produced detailed guidance for quarry workers entitled '**Safe Quarry - A Guide for Quarry Workers**' which is available electronically on the Health and Safety Authority website or a hard copy can be ordered from wcu@hsa.ie

Safety and health at work can only be achieved if everyone understands that their safety and the lives of others are in their hands. All those working at the quarry have a part to play, and are required to carry out their duties with reasonable care and comply with all relevant rules and regulations.

Anyone who identifies a significant risk, for example, because procedures or rules are not followed or where safeguards are missing or inadequate, must take appropriate action, normally by reporting it to a supervisor. Any reports of such defects and remedial actions taken should be recorded on the daily inspection sheet.

14. CONSULTATION (Regulation 17)

17. *Every operator and employer at a quarry shall consult at the quarry with their safety representatives and employees, as the case may be, in relation to the requirements of these Regulations and section 26 of the Act, taking account of the need, whenever necessary, for co-operation and co-ordination among -*
- (a) *operators and employers,*
- (b) *employees and other persons at work, and*
- (c) *the safety representatives, in order to promote and develop measures for protecting the safety, health and welfare of persons at work at the quarry and to monitor the effectiveness of such measures.*

This should be read in conjunction with Sections 25 and 26 of the Safety, Health and Welfare at Work Act 2005.

The involvement of the entire workforce in identifying and controlling risks is crucial to the reduction of the high accident/incident rate associated with quarrying. The establishment of active safety representation and/or a safety committee is a highly effective way of encouraging the co-operation and participation of the whole workforce in the safe management of the quarry and to improve standards of safety and health. To be successful, the safety representative and/or the committee must be seen by all parties as being effective.

Safety representatives and/or committee members should have suitable practical experience of quarry work, and may represent any section, or in the case of a committee, a representative cross section of the workforce at the quarry. Whilst a safety representative may be adequate for some locations others may require a committee covering the whole quarry or a small group of quarries to be successful. In a small quarry the committee may involve every member of the workforce.

Site inspections

Site inspections provide a way in which the workforce can be actively involved in practical site safety. Their detailed knowledge of the site and working practices can lead to significant improvements in safety and health. Site inspections may involve independent inspections by management and/or safety representatives. Inspections are best carried out jointly by a team representing the management and those working in the quarry including their elected safety representatives. Findings should be discussed and minuted at safety committee meetings.

Encouraging active participation

The team approach to safety and health can also be fostered by actively involving people in managing the hazards associated with their work. For example, it is best to include those affected when developing new systems; their involvement in equipment trials helps identify the best solution.

Discharging functions as a safety representative

Safety representatives selected and appointed in accordance with Section 25 of the Safety, Health and Welfare at Work Act 2005 must be allowed reasonable time off from their duties to acquire the knowledge necessary and/or discharge their functions as a safety representative without loss of remuneration.

15. RECORD KEEPING (Regulation 18)

18.

(1) *The operator shall ensure that -*

- (a) *every report, notification or other record required to be made under these Regulations is in an approved, or otherwise appropriate, form and kept at the quarry or other suitable place, but when quarrying operations have permanently ceased at the quarry the record shall be kept -*
 - (i) *at the registered office of the operator, or*
 - (ii) *where the operator is an individual, at his or her place of business for a period of 6 years, unless the provision concerned imposes a different period, and*
- (b) *a copy of the written statement of duties of all persons appointed at the quarry under these Regulations is kept at the quarry or other suitable place for at least one year from the date of termination of the person's employment.*

(2) *Subject to paragraph (1), where under these Regulations records, reports, or other documents are required to be made, it is sufficient compliance with the requirement if the operator and, where appropriate, other person concerned -*

- (a) *make and maintain the record, report or other document by electronic means, and*
- (b) *duly authenticate it as soon as is practicable afterwards.*

(3) *Without prejudice to section 64 of the Act, any person having custody of the records required by the Act or these Regulations shall -*

- (a) *ensure that the records are open to inspection by an inspector, and*
- (b) *forthwith send to an inspector such extracts from them or copies of them as the inspector may from time to time require in accordance with section 64 of the Act.*

The information contained in records required to be kept by the quarry operator must be kept available for six years. This provides data from which operators can identify and monitor trends and make judgements, for example, about plant maintenance. The retention of records also enables them to be examined by Health and Safety Authority Inspectors.

The way in which records are made and stored is left to the discretion of the operator, but the information needs to be stored accurately and to be easily retrievable. Records may be kept electronically (with suitable back up arrangements) or on paper.

The records may be kept at the quarry or other suitable place, provided that anyone who has a right to see them can readily obtain them, for example, by electronic transmission. Records required include:

- ▶ Notifications to the Authority required by these regulations
- ▶ Daily and periodic inspection records;
- ▶ Examinations for flammable/explosive atmospheres;
- ▶ Appointments of
 1. Quarry manager;
 2. Manager, supervisors, etc;
 3. Explosives supervisors;
 4. Shotfirers, storekeepers, etc.
- ▶ Blasting specifications, including drilling logs, and any face profile results;
- ▶ Any misfires including details of remedial action taken;
- ▶ The conclusion of geotechnical appraisals, site investigations and assessments;
- ▶ Reports of thorough examination of any lifting gear or lifting appliance;
- ▶ Reports of thorough examination of any compressor, air receiver or steam boiler;
- ▶ Results of vehicle brake tests;
- ▶ Records of inspection and maintenance of equipment;
- ▶ Copies of any relevant certificate or registration card issued by a recognised bodies for any person operating equipment or carrying out operations listed in Schedule 1 to the Regulations;
- ▶ Certification of inspection of electrical installations;
- ▶ Copies of permit to work documentation.

Other documents are also required which are to be included in the safety statement such as the management structure, instructions, rules and safe operating procedures, shotfiring rules, vehicle rules, and emergency procedures. These are required to be available and up to date.

16. INSPECTION, MAINTENANCE AND TESTING (Regulation 19)

19.

- (1) *The operator shall, with a view to securing, so far as is reasonably practicable, the safety, health and welfare of persons at work in the quarry -*
 - (a) *prepare and keep up to date suitable schemes for the systematic inspection, maintenance and, where appropriate, testing of -*
 - (i) *all parts of the quarry,*
 - (ii) *all buildings (whether temporary or permanent) at the quarry, and*
 - (iii) *any plant and work equipment at the quarry,*
 - (b) *ensure that suitable records are made of inspections, maintenance and tests carried out in pursuance of subparagraph (a) and that each such record lists any significant defects and the steps taken, or to be taken, to remedy them and is -*
 - (i) *signed by the person making it, and*
 - (ii) *countersigned by an appropriate person in the management structure under Regulation 10, and*
 - (c) *ensure that a sufficient number of competent persons are appointed to undertake the activities referred to in subparagraphs (a) and (b).*
- (2) *Without prejudice to the generality of subparagraphs (1)(a) and (b), the scheme shall specify that on every working day -*
 - (a) *the faces above every workstation at the quarry and every road used by persons at work at the quarry for the purpose of their work or of getting to or from their place of work are inspected for loose ground or loose rocks,*
 - (b) *faces, sides and any overburdens of the quarry that may cause danger at any place (including any road) are inspected,*
 - (c) *all external parts of all machinery and all appliances forming part of the equipment of the quarry are inspected, and*
 - (d) *where, during an inspection under subparagraph (a) or (b), conditions are observed that constitute a significant hazard,*

or a potential significant hazard, the provisions of Regulation 54 are carried out.

- (3) *The operator shall ensure that appropriate remedial measures are taken following an inspection under this Regulation.*
- (4) *The operator shall ensure that a record is made of each inspection carried out under paragraph (2) and the appropriate remedial measures taken under paragraph (3).*
- (5) *In this Regulation "inspection" means such visual or more rigorous inspection by a competent person as is appropriate for the purpose.*

A scheme is required for the inspection and maintenance of the whole quarry and its plant. The operator should design and implement a site specific inspection scheme for all parts of the quarry. The scheme should include all, roads, excavations, overburden, bunding, edge protection, tips and lagoons, along with any buildings and work equipment. The focus should be on identifying dangerous or potentially dangerous situations and correcting them before incidents occur. The inspection scheme should also take account of the inspection and maintenance schemes for periodic thorough examination required by other legislation and not as a substitute for them.

Work equipment being brought onto site from another location should be accompanied by evidence that it has been properly inspected and is safe for use. The scheme will be sufficient if these records are checked at appropriate intervals as long as they are found to be satisfactory.

An inspection may vary from a simple visual inspection to a thorough examination, involving some dismantling and/or testing. The level of detail needs to be sufficient to ensure that no one is likely to be put at risk. Where a visual examination is adequate for this purpose, dismantling or testing is not required.

The scheme needs to particularly target those areas of the quarry and its plant which are liable to create significant risks, including off-site risks, if conditions deteriorate. (Off-site risks are risks affecting areas outside the quarry boundary such as dwellings, schools, roads or other places of work arising from quarrying operations or geological failures such as potential instability of tips, lagoons and stockpiles, and dangers from blasting operations.) These areas

should have been identified in the safety statement as a result of hazard identification, risk assessments, and geotechnical appraisals or assessments.

The detail of the scheme for the quarry will also depend on the work activities, the nature of the materials, face and tip heights and weather conditions. For example, periods of heavy rain may result in loose materials, failures of tips and faces, and roads being washed away.

The scheme needs to include information on the frequency and level of detail of inspection, and the experience and any qualifications required by the people involved. It should, where necessary, include practical advice as to what defects are significant and on action to be taken if defects are found, particularly in cases of imminent risk. It is particularly important that the scheme covers:

- (a) vehicles;
- (b) machinery guarding;
- (c) safety devices such as reversing aids, interlocks and trip wires and emergency equipment;
- (d) quarry electrical equipment;
- (e) pressure systems including air receivers on vehicles;
- (f) pedestrian routes, roadways and edge protection;
- (g) excavations, tips and lagoons;
- (h) buildings or other structures where a significant reduction in the structural integrity, for example by corrosion, decay, overloading or impact damage, is foreseeable;
- (i) any barriers that are required around the quarry; and
- (j) any equipment required to carry out shotfiring operations.

It is likely that the scheme will take the form of a general inspection to which more detailed schedules for different types of plant and areas are attached.

Faces above working places must be inspected to ensure that loose ground or rocks do not create significant risks. In other cases where the risk of deterioration is high, inspection will also be required at least once per shift. These inspections may identify a need for maintenance work, such as scaling, or influence the frequency of future inspections.

In all cases, the frequency of inspection needs to be reviewed in the light of experience but a daily inspection must be carried out by a competent person and a record of each daily inspection made.

The daily inspection must include the inspection of:

- ▶ Working quarry faces, sides and overburden;
- ▶ Every road used by persons at work are to be inspected for loose ground or loose rock; and
- ▶ All external parts of all machinery and appliances.

There is no generic record form for daily inspections and one must be prepared according to the operations carried out at the quarry or at least in line with company procedures but it must at least address the matters listed above. A sample inspection record is shown overleaf:

Figure 3: Sample Daily Inspection Record for a Quarry

QUARRY		DAILY INSPECTION		DATE	WEATHER
Area	Condition of Face	Comments			
West Face	Some loose at upper part of face	From last blast (01/05/08), to push down with excavator today.			
East Face	Good – No Loose	Not worked for 2 Months			
South Face	OK	Drilling to commence today, holes position marked up			
		Condition of Haul Road			
West Haul Road	Requires improvement on Ramp	Height of Edge Protection to be raised with scalplings - Ongoing			
East Haul Road	OK	Direction Arrow Signs to be installed, on Order			
South Haul Road	Some Potholes to be filled	Ongoing			
		Observations			
Mobile Plant	Reversing Siren not working on Articulated Dumptruck	Electrician to check out			
	Idler Roller guard missing on Mobile Crusher	Fitter making new guard			
Fixed Plant	Checked all Pull-wires OK	Checked all Pull-wires OK			
	All Guards in place	All Guards in place			
Other Matters					
<i>John Smith attending Excavator Driver Training Today</i>					
Person making this report & position;				Signature;	
<i>A. Foreman Asst Quarry Manager</i>				<i>A Foreman</i>	

16.1 Imminent Risks

If an imminent risk of serious injury is discovered during an inspection, the scheme must require immediate action to safeguard those at risk. This may include, for example, suspension of work in the area or the taking of an item of plant out of use. Situations where such action is likely to be appropriate include:

- ▶ loose ground or overhanging rocks above a loading point, roadway or workplace;
- ▶ a vehicle with inefficient brakes or faulty steering;
- ▶ missing edge protection on roads, benches, ramps and tipping points;
- ▶ machinery with missing guards or faulty safety devices, etc.

Figure 4: Crushed by Face Collapse



16.2 Records of Inspection and Maintenance

Records, which may be computerised with digital signatures, should be kept for all inspections, unless this would involve disproportionate effort, for example, where small tools are inspected by their user before use and the time taken to carry out the inspections is less than the time to record it. Records will always be required, however, where significant defects are found, unless the tool is immediately scrapped. Records are also required for any third party periodic inspections carried out, for example, by an insurance engineer, an electrician, etc.

Records must show when the inspection was carried out, details of any significant defects found and any remedial action taken. Significant defects are those which:

- ▶ create a significant risk; or
- ▶ may indicate the existence of a significant design or maintenance problem.

The report must be signed by the person making it, and countersigned by an appropriate manager or supervisor. This needs to be someone who can judge whether proposed remedial measures are appropriate and authorise them. Types of defect which need to be brought to the personal attention of the quarry manager, or other designated person, should be identified in the scheme.

Sometimes equipment is inspected by, or on behalf of, the operator although it belongs to another person, for example, a hire company or a contractor. In such cases, the owner of the equipment should be informed of any defects found.

Anyone who notices a hazard related to the condition of the quarry or its equipment should bring it to the attention of the supervisor or manager without unreasonable delay.

A sample checklist and report form is shown overleaf at Figure 5. It is a model which should be tailored to the needs of a particular quarry. It is not intended to be used exclusively as it is presented.

Figure 5: Sample inspection form for periodic inspection

Quarry	Weather	Last Inspected		Date
Condition of excavated face/tip/lagoon	Feature observed		Details of condition and location	
Crests	Yes	No	Details	
Lowering of ground surface at or behind the crest of the overall slope/bench				
Cracking behind the crest of the overall slope/bench				
Water running over the crest of the overall slope/bench				
Water entering cracks behind the crest of the overall slope/bench				
Surcharging of ground behind the crest of the overall slope/bench				
Face	Yes	No	Details	
Bulging at the slope face				
Settlement of the slope face				
Displacement across joints/bedding planes etc				
Open structural features inclined > 10 degrees out of the face				
Open structural features inclined steeply > 70 degrees out of the face				
Loose material on the face				
Irregular slope gradient				
Irregularities in plan of the slope face				
Water issuing from the face				
Drainage blankets blocked				
Toe	Yes	No	Detail	
Ground movements at or in front of the toe of the overall slope/bench				
Water issuing from or in front of the toe of the overall slope/bench				
New accumulation of water at the toe of the overall slope/bench				
Excavations at or near toe of structure not as per design of quarry/tip				
Water courses/lagoons behind crest	Yes	No	Details	
Wave erosion of embankment/bank erosion				
Inflow, outflow or storm overflow impeded.				
Is freeboard less than specified in the tipping rules				
Signs of damage due to animals				
Escape of material in suspension or solution				
Indications of silting				
Impending or partial blockages				

Quarry	Weather	Last Inspected	Date
<input type="text"/>	<input type="text"/>	<input type="text"/>	<input type="text"/>
Condition of excavated face/tip/lagoon		Feature observed	Details of condition and location
Other observations		Yes	No
Adverse drainage from access roads			
Indication of recent ground movements			
Construction varying from plan or tipping rules			
Instruments damaged, recording movements or rises in water level			
Recent or active rockfall			
Recent or active slope failures			
Unexpected geological conditions appeared since last inspection.			
Other changes in slope condition or features of note.			
Indications of burning			
Variations from design			
Benches and haul roads		Yes	No
Are the benches and haul roads stable and without signs of failure.			
Any changes in the quarry geology or slope conditions affecting stability			
Are haul roads of adequate width and safe gradient?			
Are there excessive ruts, potholes or bumps?			
Is edge protection adequate?			
Has the approved excavation procedure been followed?			
Are quarry loading areas of adequate size			
Comments		Action required	
<input type="text"/>		<input type="text"/>	
Safety and stability of the excavated slopes/tips			
Recommendations for immediate action			
Signed.....		Date.....	
Recommendations agreed or varied			
Signed.....		Date.....	
Action taken to remedy defects			
Signed.....		Quarry Manager	

**17. SAFETY EQUIPMENT
(Regulation 20)**

20. *The operator shall ensure that adequate safety equipment is maintained, ready for use and in good working order at all times and such maintenance is undertaken with due regard to ongoing activities.*

This is a general requirement on employers to provide and maintain safety equipment that may be needed by employees in the course of their normal work and/or during work involved in adjustments or maintenance. A particular example would be; ensuring safe access when working at a height. Where for instance an employee has to work at a height a safe means of access such as stairs or other means should be provided. The means of access must be of sound construction, properly maintained and securely fixed. However such safe means of access may not always be in place and other equipment may be required.

Where safety equipment such as harnesses and fall arrest devices are used, secure anchorage points must be provided, safety lines should be short enough to prevent injury from falls. Arrangements must be put in place to ensure that such safety equipment is readily available and used when required. Safety equipment must be properly maintained and stored for future use.

**18. BENCHES AND HAUL ROADS
(Regulation 21)**

21. *The operator shall ensure, so far as is reasonably practicable, that -*

- (a) *benches and haul roads are designed, constructed and maintained so as to allow vehicles and plant to be used and moved upon them safely, and*
- (b) *where there is a risk of vehicles or plant accidentally leaving any bench or haul road, adequate precautions are taken by the installation of barriers or otherwise to control such risks.*

The proper design of benches and haul roads is essential. They must be suitable for the type and size of machinery and loads used on them. Vehicles must be able to move safely and without risk of accidentally leaving the bench or from any instability of the face or bench. The operator also needs to consider the effect of vibration on the bench or haul road from the use of any explosives. The minimum width of a haul road is dependent on the width of the largest vehicle that

passes along it and if there is to be single or two-way traffic. Recommended haul road widths are given below, however it is accepted that these may not be always achievable in some instances.

Figure 6: Recommended haul road width (single vehicle).

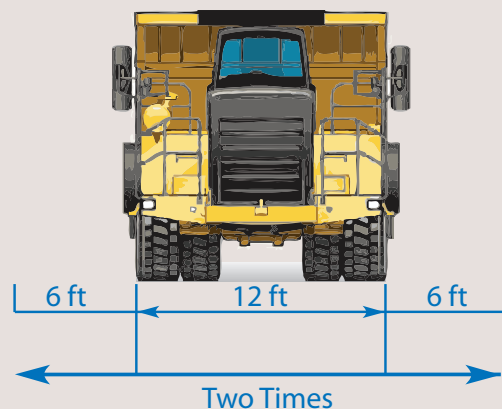

First identify the width of the widest vehicle that will use that road. For example, this one is 12 feet (3.7 metres) wide. If we want a one-lane road we begin with 12 feet (3.7 metres) for that lane. Now to make that lane safe we would add half of the width of the truck, in this example 6 feet (1.85 metres), for an open area on each side of the 12-foot (3.7 metres) lane. This results in a 24-foot (7.4 metres)-wide lane. So the recommended width for one lane of traffic is twice the width of the widest

Figure 7: Recommended haul road width (two-way traffic)

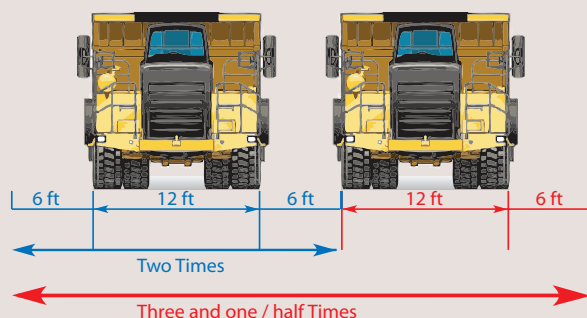

Now if we have traffic going both ways (as we usually do) we would take the width of the widest vehicle, and have a lane for it. Again we would have 6 feet (1.85 metres) on each side for a 12-foot (3.7 metres)-wide vehicle. Now the area in the middle, 6 feet (1.85 metres) in this circumstance, can be shared. So for a two lane road you would have to have a road 3½ times the width of the widest vehicle (42 feet (12.9 metres) wide in this case).

The minimum width of the bench, and the type of machinery, which can be safely used on it, should be considered during the design, appraisal and where appropriate, the geotechnical assessment of the excavation, tip or lagoon. They should be reviewed as the working methods and the excavation, tip or lagoon develop. Benches need to be wide enough for the type and volume of traffic using them and take account of the traffic systems in force, for example, one-way systems.

Benches and haul roads must be designed to avoid dangerous sharp bends and gradients. They must also be maintained so that they do not develop bumps, ruts or potholes that may make vehicles difficult to control or cause health problems due to whole-body vibration. The maximum gradient upon which vehicles can operate should be specified by the supplier but is also dependent on maintenance, the quality of the haul roads, the weather conditions and the condition of the braking system. As a rule of thumb, and to avoid excessive wear on vehicles, the grade should not exceed 10% (1 in 10) except for short periods.

Figure 8: Grade as a percentage

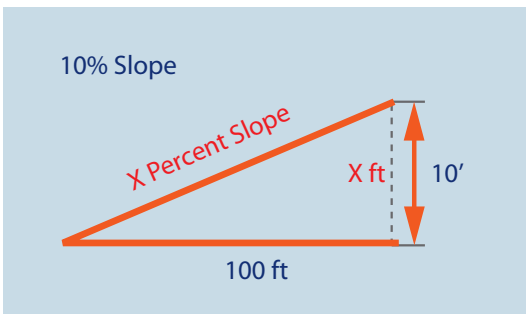
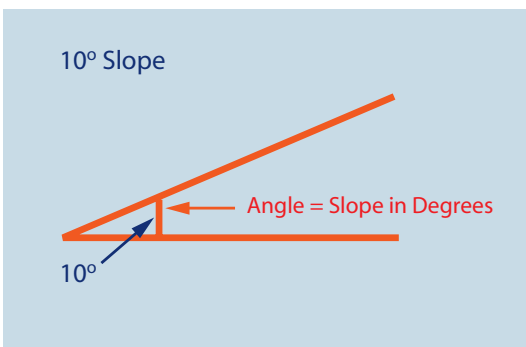

Figure 9: Grade as an angle



Adequate edge protection must be provided on haul roads where there is a drop, the potential for edge failure, a lagoon, excavation or other hazard which would put the driver, or others, at significant risk if the vehicle left the bench or roadway. The aim of the edge protection is to stop the largest, fully loaded vehicle crossing it when travelling at the maximum foreseeable speed and it should be constructed with this in mind.

Figure 10: Comparison percent v degrees

Percent Vs Degrees	
1.0	0.6
5.0	3.0
10.0	5.7
15.0	8.5
17.06	10.0
20.0	11.0

Figure 11: Excessive gradients



Edge protection may consist of purpose-made crash barriers or suitable bunds made from quarried material, for example oversized rock and scalplings.

On benches or roads used by heavy vehicles the minimum acceptable height of the edge protection is 1.5 metres or the radius of the largest wheel/tyre – whichever is the greater. Additional protection is needed in high-risk areas, such as sharp bends or

steep haul roads, where sand traps or other means should also be considered.

Bunds can deteriorate due to weathering and so must be properly inspected in accordance with section 16 of this guidance. Where necessary to ensure the drainage of surface water, gaps may be left in the bunds, or other drainage systems provided. Any gaps must not be wide enough to allow a vehicle to pass through.

Edge protection less than either 1.5 metres or the radius of the vehicle wheel or with sloping sides, makes an ideal ramp for a vehicle to run over and is totally ineffective. Blocks of stone or oversize rocks placed on their own along the edge of a bench, ramp or roadway, which may be easily pushed out of the way by a vehicle at speed, are not suitable for edge protection.

A bank of unconsolidated material like scalplings is suitable if it is big enough to allow the vehicles momentum to be absorbed. The impact face needs to be as vertical as possible and at least 1.5 metres or the radius of the largest wheel/tyre.

Rocks can be used if they can safely absorb the impact, for example, by heaping materials like scalplings between and behind the rocks to provide an adequate barrier. A violent stop due to impact would, of course, increase the risk to the driver, and of damage to the vehicle and so should be avoided.

19. SAFEGUARDING EDGES OF EXCAVATIONS AND LAGOONS (Regulation 22)

22. The operator -

- (a) shall ensure that material is not placed or stacked at the quarry near the edge of any excavation or lagoon, where it is likely to endanger persons at work,
- (b) shall not at the quarry -
 - (i) place or move, or
 - (ii) allow to be placed or moved, any load, vehicle, plant or equipment near the edge of any excavation or lagoon where it is likely to cause a collapse of the side of the excavation or lagoon and thereby endanger any person at work, and
- (c) where necessary, shall ensure that appropriate barriers are provided.

Materials placed or stacked at the edge of excavations or lagoons should not endanger the safety of persons at work.

Vehicles, plant or equipment or any loads should not be operated or placed close to the edge of excavations or lagoons that may endanger the vehicle operator or other persons working in that area. Appropriate barriers should be provided where necessary and where the excavation or lagoon is close to a haul road where vehicles operate then the edge protection shall be in accordance with the requirements of Regulation 21.

Figure 12: Vehicle over running an edge



Figures 13,14,15,16: Edge protection for vehicles at quarries

Figure 13: Edge protection less than 1.5metres or the radius of the largest vehicle

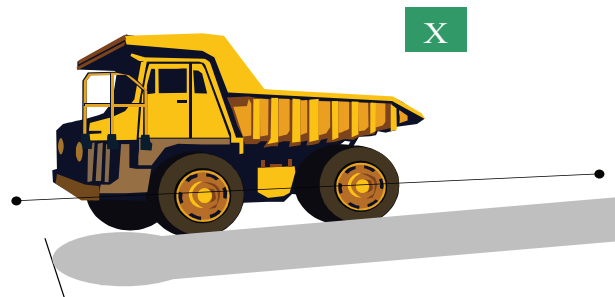

Figure 14:
Boulders or blocks of stone used as edge protection that can be easily pushed aside

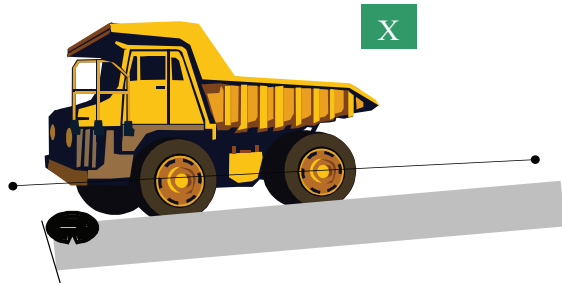

Figure 15:
Consolidated bank of material large enough to absorb a vehicles momentum

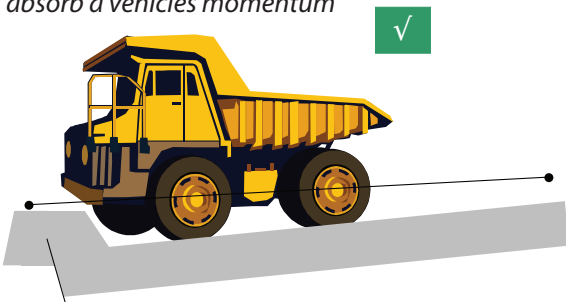
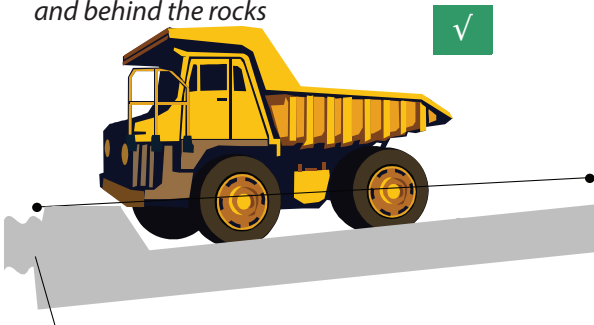

Figure 16:
Rocks with heapings of scalplings between and behind the rocks



20. VEHICLES AND TRAFFIC RULES (Regulation 23)

23.

- (1) *The operator shall make suitable vehicle and traffic rules in order to prevent, as far as reasonably practicable, the risks to persons arising from the use of vehicles at the quarry, including where machines or vehicles enter or leave the quarry.*

- (2) *The operator shall ensure that transport vehicles, earth-moving machinery, materials-handling machinery and locomotives used at the quarry, including those operated by another employer at the quarry -*
- (a) *are of good design and construction taking into account as far as possible ergonomic principles,*
 - (b) *are maintained in good working order,*
 - (c) *are properly used,*
 - (d) *are not operated otherwise than by -*
 - (i) *a competent person who has attained the age of 18 years, or*
 - (ii) *a person of 16 or 17 years under the close personal supervision of a competent person for the purpose of his or her training, and*
 - (e) *are provided, in the case of the earth-moving machinery and materials-handling machinery specified in Schedule 2, with appropriate devices which, where the visibility of the operator is restricted, remedy the hazards arising from inadequate direct vision..*

A large number of people have been killed both in Ireland and throughout the world in transport related accidents at quarries and many of these involve reversing or moving vehicles. It is, therefore, vitally important that the hazards associated with vehicles are identified and the risks controlled. Good, well enforced, vehicle rules can make a significant contribution to reducing deaths and injuries at quarries.

The procedures must deal with management of all vehicles and mobile machinery on site; rules, which only cover instructions for drivers, are not sufficient. The rules must cover contractors' and private vehicles as well as railway trains on private railways or sidings within the quarry.

The rules and procedures should be brought to the attention of those affected by them and reviewed as necessary. The rules should be set out in a way, which takes account of how risks vary from one part of the quarry to another. For example, rules for the excavation area might be irrelevant elsewhere and some vehicles may be banned from certain areas. In particular the rules need to cover:

- (a) how drivers are to be assessed for competence, and authorised to operate vehicles;
- (b) security arrangements, including control of keys;
- (c) any restrictions on where vehicles may be used, for example, due to height, width, gradient;
- (d) Any restrictions on reversing;
- (e) Speed limits;
- (f) Restrictions on traffic routes, for example, one-way arrangements;
- (g) Pedestrian safety;
- (h) Fitting and use of safety devices, including visibility aids, e.g. mirrors, CCTV, radar, lights, etc.;
- (i) Use of vehicles in adverse conditions, for example, fog, rain, mud, ice, etc.;
- (j) Precautions where quarry vehicles or trailers with tipping bodies or tipping gear are loaded, unloaded or sheeted;
- (k) Instructions to drivers concerning the reporting of defects;
- (l) Relevant cross-references to the scheme for inspection and maintenance of plant; and
- (m) The wearing of PPE and the use of suitable seat belts.

Vehicle safety in quarries

A multi-faceted approach is needed to significantly reduce the level of transport accidents in quarries and it must address all the risk factors involved as illustrated in the diagram below.

Figure 17: Responsibilities for ensuring safe operation of vehicles

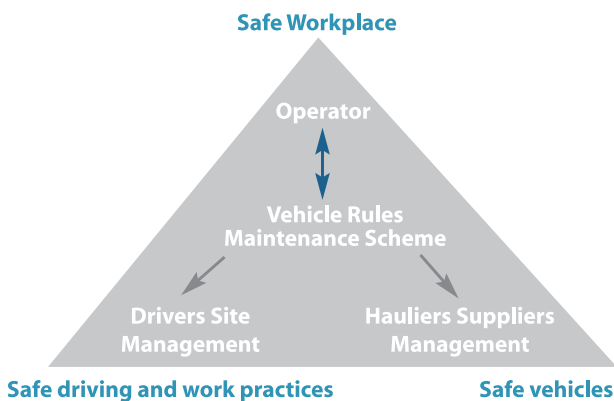

The key elements in improving vehicle safety are:

- ▶ designing the workplace to minimise the hazard;
- ▶ using vehicles which are suitable, and well maintained;
- ▶ establishing and following safe driving and working practices;
- ▶ trained, skilled and responsible drivers.

These issues can only be addressed if all parties involved co-operate in identifying and controlling hazards.

Safe Vehicles

Vehicles must be suitable for the place in which they are to be used and for the work they undertake. The selection of suitable work equipment can reduce or eliminate many risks at the quarry. It is generally much easier and cheaper to start with the right equipment than to modify it later. The following are important factors to consider when choosing a vehicle:

Figure 18: Unsafe tipping points



Figure 19: Safe tipping point



Figure 20: Excavator with falling object protection provided



- (a) The effectiveness of the braking system and engine torque, bearing in mind the slopes it is expected to operate on;
- (b) Adequate all round visibility for the driver;
- (c) Stability under all foreseeable operating conditions;
- (d) Protection for the driver and any passengers from falling objects (falling object protective structure) and overturning (roll-over protective structures and restraining devices);
- (e) Safe access to and from the cab and other areas to which access may be required;
- (f) Lights, windscreen wipers, horn and other warning devices;

- (g) Guarding of dangerous parts during use or maintenance work;
- (h) Protection for the drivers and any passengers from rain, high or low temperatures, noise, dust or vibration;
- (i) Suitable seating for the driver and any passengers; and
- (j) Adequate seatbelts or restraining devices for drivers and passengers.

Visibility

To manoeuvre safely the driver needs to be able to see all around the vehicle or to be automatically warned if there is a person or object in the danger area. Where necessary, vehicles should be designed to provide adequate visibility and be fitted with windows (including side windows), mirrors, closed circuit TV and sensing equipment as appropriate.

Many vehicles have substantial blind spots not only immediately behind the vehicle, but also alongside and immediately in front of it. Accidents occur when vehicles move off or turn while a pedestrian or vehicle is passing in blind spots. How to avoid these blind spots is illustrated in figures 21 and 22 below.

Even when the driver's visibility is considered adequate, pedestrians should, so far as is reasonably practicable, be kept out of the area where vehicles operate.

Significantly smaller vehicles may be at risk of being crushed. Like pedestrians, they should ideally be kept away from areas where large vehicles operate. If this

Figure 21: Improved all round visibility provided by CCTV system

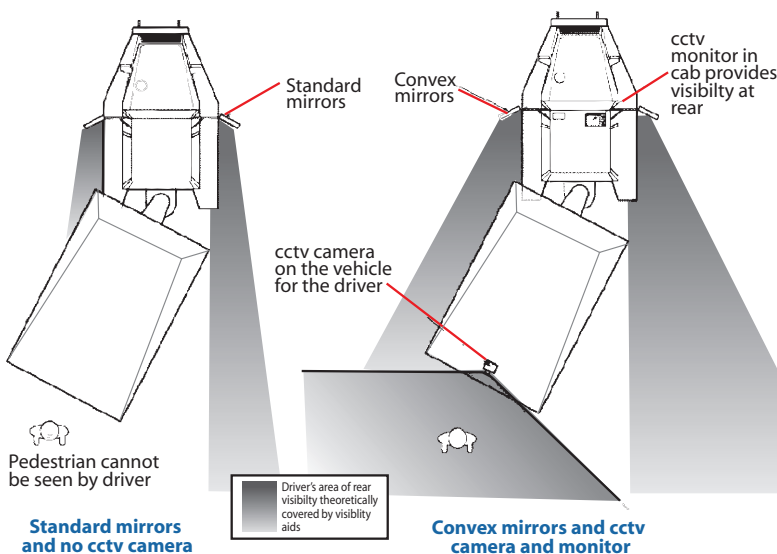
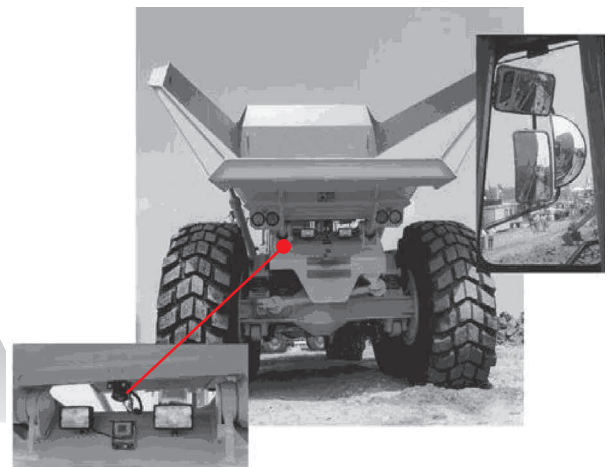

Figure 22: Photomontage of a large dumper truck fitted with CCTV and mirrors to improve visibility from the driving position



cannot be achieved small quarry vehicles should be painted with distinctive colours, fitted with flashing lights or otherwise made readily visible to drivers of other vehicles.

Restraining Systems

Many injuries are the result of vehicles overturning. All drivers and passengers, when reasonably practicable, should wear appropriate seat belts and, if necessary, the wearing of such seat belts should be required by the Quarry's Vehicle rules.

Seats

Vehicle seats should be maintained and adjusted to minimise the adverse affects of whole-body vibration on the driver, particularly where vehicles are used on rough terrain. Vehicle seats will generally not last as long as the vehicle itself and will need to be replaced a number of times during the lifetime of the machine.

Maintenance

(a) Brake Testing

A suitable inspection scheme is required to ensure brakes are in good condition on all loading shovels, dumper trucks and some other rubber tyred vehicles such as tractors operating in the quarry. Monitoring the braking capabilities of a quarry vehicle is an essential part of vehicle safety and is closely allied with brake maintenance. Any monitoring system must start with the participation of vehicle drivers, who should carry out a series of simple checks at the start of the working day or shift and record their observations in a daily vehicle inspection book or sheet. This should include if the braking is causing the vehicle to pull towards either side

The testing of the service brake only checks the effective use of the brakes. It may not identify other faults in the braking system. It is for this reason that maintenance of the whole of the braking system should be carried out in accordance with the manufacturer's recommendations.

Brake maintenance schedules will not only include adjustment, fluid levels, pressures etc., they will also contain the replacement of seals and other vital components in accordance with the manufacturer's recommendations.

Emergency braking systems should also be included in regular inspection and testing programmes. Contractors' vehicles working in quarries should be subject to the same brake testing schemes.

A driver's daily check is not a sufficient control measure on its own; it must be supported by regular instrumented tests completed by a competent person using an electronic brake efficiency meter.

The Health and Safety Authority have prepared an information sheet entitled **Quarry Vehicle Brakes Maintenance And Testing** which is copied in Appendix 5 of this document and this details the frequency and scope of the periodic brake testing of vehicles.

(b) Tipping Bodies

Suitable and adequate measures should be in place and/or vehicles should be fitted with devices to prevent tipping bodies from accidentally collapsing from the raised position during maintenance.

It is useful to put a notice on the vehicle to reinforce the use of the devices. Raised body alarms can reduce the risk of vehicles being 'tipped' and striking objects.

Figure 23: Two means of supporting a tipper body by CCTV system



Two Acceptable Methods of Supporting a Tipper Truck Body During Maintenance Operations

(c) Tyre Changing or repair

There are a number of hazards associated with tyre changing and repair and these should all be addressed prior to any work being carried out:

- (i) If a vehicle is to be raised to remove the wheel then the vehicle must be adequately supported to prevent any danger of collapse and the operation must be carried out on solid ground that will not fail resulting in collapse;
- (ii) Adequate lifting equipment and restraining equipment must be available to remove the wheel to be changed or removed and the wheel must never be left free standing where there is a danger of it falling and causing injury;
- (iii) Inflation of tyres should be carried out from a position of safety and where necessary a suitable tyre cage is required and the sidewall of the tyre should be inspected prior to inflation to ensure it is not defective;
- (iv) After changing or refitting of a wheel the wheel nuts or clamping devices must be correctly installed and tensioned;
- (v) Tyres and wheels which are to be taken off site for repair or disposal must be stored so that they will not endanger persons as a result of collapse; and
- (vi) Good standards of housekeeping should be maintained.

Figure 24: Wheel handling equipment



Dumper Wheel changing

- Modified forks - ideal kit
- Forklift, or better still, a *telehandler*, is an invaluable addition to any quarry

The Health and Safety Authority and the Health and Safety Executive for Northern Ireland have developed an information note entitled **Inflation of Quarry Vehicle Tyres** which is copied in Appendix 5 of this document and provides information on safe tyre inflation

(d) Controlling Exposure of Drivers to Dust at Quarries

Vehicles travelling around quarries will create, or cause, dust to be raised. This dust can be reduced at source by, for example, the use of water suppression at conveying and processing points. It can also be reduced by watering of haul roads using a vehicle with a bowser or similar equipment that will dampen the dust and prevent it becoming airborne. Drivers can reduce their exposure to airborne dust by ensuring that the windows of their vehicles remain closed whilst at the quarry and thereby prevent the access of the dust into the cab. Similarly, doors of vehicles should only be open for the minimum time required.

Most modern quarry specific vehicles have air conditioning systems which filter out any respirable dust before it enters the cab and they ensure a controllable climate so that windows do not need to be opened to reduce the temperature. Air conditioning systems must be maintained and the filters must be cleaned or changed at periods stated by the supplier. To prevent re-circulation of dust within the cab of the vehicle it is important to keep the cab free from dust by good housekeeping and, where necessary, by vacuuming of the cab to remove the dust.

Safe Practices**(a) Drivers of Quarry Vehicles**

Drivers should be competent to operate quarry vehicles and drivers need to be authorised, in writing by the appropriate manager. Training should be given by an accredited person as established under Schedule 1 of the Regulations. The need for refresher training should be considered.

The training required is not limited to the operation of the vehicle; it also needs to cover the hazards related to its use in the workplace and how these are controlled, for example, by the vehicle operating procedures. The driver should not be exposed to excessive noise, dust, or vibration. The driver should know who to contact and/or what action to take if he or she has any difficulties with the vehicle they are operating.

(b) Speed of Vehicles

The speed of vehicles should be appropriate for the conditions at the quarry site. Different speed limits may be needed in different parts of the quarry. These limits should be indicated by the use of suitable signs. If speed limits are being contravened consideration should be given to physical means of reducing the speed of vehicles by the use of speed ramps, sleeping policemen, artificial chicanes or other means.

(c) Reversing

Reversing is recognised as a significant driving hazard, particularly in confined areas. The risk involved can be reduced by:

- (i) minimising the need for reversing by the use of one-way systems and adequate turning areas;
- (ii) ensuring adequate visibility for the driver;
- (iii) providing safe systems of work;
- (iv) providing adequate supervision and training.

In areas where reversing is unavoidable there must be effective arrangements to ensure that it is safe to reverse. To reverse safely, the driver needs to be able to see the danger area at the rear of the vehicle, or receive automatic warnings of any obstruction. The area must

be clear of any pedestrians and other vehicles when reversing takes place. Where safe reversing relies on reversing aids, for example, closed-circuit television or radar, the vehicle should not be used if the devices are defective. When it is dark, the site lighting and vehicle lights should provide sufficient illumination for the driver to see clearly when reversing.

No single safeguard is likely to be sufficient on its own during reversing. All the relevant precautions need to be considered together as outlined in figure 25.

(d) Overhead Power Lines

Overhead power lines at a quarry are likely to pose a significant risk, unless vehicles are prevented from approaching them. Vehicles do not need to strike the overhead lines for injury to occur; electricity can arc through a surprising distance depending on the voltage and weather/atmospheric conditions. Precautions such as those illustrated in figure 26 are required if it is possible for a vehicle to reach the danger zone around the cables. Assessment of the risk must take account of the possibility of tipper trucks travelling when tipped.

Figure 25: Control measures for reversing operations

ELIMINATE THE NEED TO REVERSE	IMPLEMENT ONE-WAY SYSTEMS AROUND SITE AND IN LOADING AND UNLOADING AREAS. PROVIDE DESIGNATED TURNING AREAS
REDUCE REVERSING OPERATIONS	REDUCE THE NUMBER OF VEHICLE MOVEMENTS AS FAR AS POSSIBLE INSTRUCT DRIVERS NOT TO REVERSE, UNLESS ABSOLUTELY NECESSARY
ENSURE VISIBILITY IS ADEQUATE	FIT CCTV, RADAR, CONVEX MIRRORS ETC TO OVERCOME RESTRICTIONS FOR DRIVERS VISIBILITY FROM THE DRIVERS SEAT, PARTICULARLY AT THE SIDES AND REAR OF VEHICLES
ENSURE SAFE SYSTEMS OF WORK ARE FOLLOWED	DESIGN VEHICLE REVERSING AREAS WHICH: <ul style="list-style-type: none"> ▶ ALLOW ADEQUATE SPACE FOR VEHICLES TO MANOEUVRE SAFELY; ▶ EXCLUDE PEDESTRIANS ▶ ARE CLEARLY SIGNED; AND ▶ HAVE SUITABLE PHYSICAL STOPS, EG BUNDS OF MATERIAL OR BUFFERS, TO WARN DRIVERS THAT THEY HAVE REACHED THE LIMIT OF THEIR SAFE REVERSING AREA ENSURE EVERYONE ON SITE UNDERSTANDS THE VEHICLE RULES INSTRUCTIONS AND SAFE OPERATING PROCEDURES ENSURE ALL VEHICLES ON SITE ARE FITTED WITH APPROPRIATE WARNING DEVICES CHECK THAT THE PROCEDURES WORK IN PRACTICE AND ARE ACTUALLY BEING FOLLOWED.

If work needs to be carried out below power lines and it is possible that cranes, excavators or other vehicles, could reach into the danger zone, the lines should normally be isolated and earthed before work begins. If this is not possible, physical safeguards such as chains on the boom may be required to prevent vehicles reaching into the danger area. Guidance should be sought from the Electricity Supply Board (ESB).

Figure 26: Overhead cable protection at a traffic route

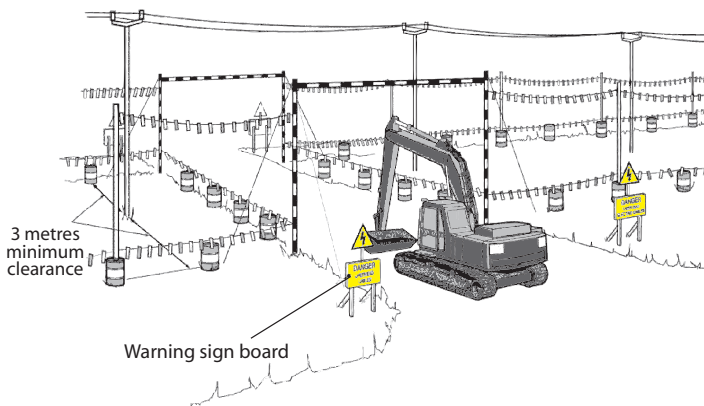

(e) Road Vehicles

These include all road vehicles used at a quarry, including those operated by hauling companies or owner-drivers, except for purely private vehicles. If the on-site risk is the same as when a vehicle is used on public roads then additional safeguards are unlikely to be needed. If, however, the risk is different or greater because of the way a vehicle is used or because of site conditions, additional precautions may be required. In such cases, these should be included in the vehicle operating procedures, for example, a requirement to have reversing lights or sirens or possibly CCTV and convex mirrors installed.

(f) Carrying Passengers

Passengers should never be carried on vehicles unless the vehicle has a designated passenger seat. Passengers should not be carried on the side of or the back of vehicles even if for only short distances. It is important that any contraventions of this are acted upon immediately and that the dangers from such actions are explained to both the driver and the person riding on the vehicle. The only acceptable exceptions to this would be when brake testing is carried out, as the person carrying out the test may need to be in the

cab alongside the driver, or when the driver is showing a maintenance person a particular fault that can only be observed inside the vehicle cab.

21. DANGER AREAS (Regulation 24)

24. (1) The operator shall ensure that -
- danger areas are clearly marked,
 - equipment or barriers are installed at any danger area to restrict inadvertent entry to that area by persons at work not authorised to enter,
 - where a person at work is authorised to enter a danger area, appropriate measures are taken to protect his or her safety, health and welfare.
- (2) In this Regulation "danger area" means an area of the quarry at which there is a significant risk to the safety, health or welfare of persons working there, due to the nature of the work being carried out there (including a risk of a person falling a distance likely to cause personal injury) or for any other reason.

All parts of quarries by their nature can contain a number of potential hazards and unauthorised entry should be discouraged by, for example, the placement of warning signs and barriers. Additionally, risk assessment should be used to identify particularly hazardous areas which merit being treated as danger areas.

Workers should only be authorised to enter hazardous danger areas if it is essential to do so and when appropriate safeguards have been adopted. A safe system of work is required for all work activities and in danger areas this may involve a permit to work system as detailed under Section 12 of this guidance.

Areas of the quarry where there are significant health hazards may also need to be identified and treated as danger areas, for example, where there are high noise or dust levels. It is always better, however, to control these risks at source.

Danger areas at a quarry where access is required and there is significant risk should be treated as hazardous areas and appropriate precautions taken.

Consideration needs to be given to:

- ▶ sections of the excavation, particularly where there are significant overhangs, which are liable to collapse;
- ▶ edges of excavations, particularly water-filled excavations, which are liable to collapse;
- ▶ places from which persons can fall from height;
- ▶ places where falling objects such as stones may fall from faces or sides;
- ▶ places that contain soft materials or deep water where a risk of drowning exists; and
- ▶ hazardous maintenance activities.

No barrier can totally prevent access by a determined person, but barriers should clearly identify the boundary of the danger area and be appropriate to the risk. Barriers can consist of tensioned ropes or straps. Fences or earth bunds, which provide equivalent protection, are also acceptable as well as anything which provides similar protection and this must be based on an assessment of risks.

The consequences of objects falling on workers, or persons falling from a height over quarry edges or through cat-walk or floor openings or into corrosive or poisonous liquid or into lagoons or settling ponds are so serious that high standards of protection are required.

Figure 27: Signage, bunding and rescue equipment at a sand & gravel lagoon



Figure 28: Face Edge Bunding system in Operation



Quarry Workers marking out drill holes with fall protection provided by bundled edge protection made from quarried Material.

The quarried material in the barrier should be in place before drilling commences. This is best achieved by placing the quarried material behind the last row of holes of the planned blast so that when the blast is taken the next barrier is in place.

Figure 29: Installing quarry face edge protection



In this system aluminium poles are inserted into pre-drilled holes approximately one metre deep. These holes are drilled behind the last line of blast holes so that they can be reinstalled immediately following blasting. Two tensionable fibre straps are connected between poles up to 20 metres apart.

Figure 30: Installing quarry face edge protection



Netting or intermediate bands can be used to maintain a constant distance between the straps. Straps are then tensioned to provide a strong fence at the working area up to any length. This temporary fencing can remain in place until the area is ready for blasting when it is removed to a place of safety until it is required to be re-erected.

Secure fencing should normally be provided to prevent people falling from edges, and the fencing should also be adequate to prevent objects falling onto people. Where fencing cannot be provided or has to be removed temporarily, other measures should be taken to prevent falls.

The Health and Safety Authority have produced an information sheet entitled **Fall Protection at the Top of the Quarry Face** which is available electronically on the Health and Safety Authority website and is copied in Appendix 5 of this document and provides information the provision of edge protection

22. TRAFFIC ROUTES (Regulation 25)

25. *The operator shall ensure that -*

- (a) *traffic routes, including stairs, fixed ladders, loading bays and ramps, are designed, located, laid out and made negotiable to ensure easy, safe and appropriate access in such a way as not to endanger persons working in the vicinity of these traffic routes,*
- (b) *routes used for pedestrian or goods traffic, or both, including those used for loading and unloading, are dimensioned in accordance with the number of potential users and the type of activity concerned,*
- (c) *if means of transport are used on traffic routes, a sufficient safety clearance or adequate protective devices are provided for other quarry users, and routes are clearly marked, regularly checked and properly maintained,*
- (d) *sufficient clearance is allowed between vehicle traffic routes and doors, gates, passages for pedestrians, corridors and staircases, and*
- (e) *traffic routes are clearly identified for the protection of persons at work.*

The vehicles normally present at quarries include, loading shovels, rigid & articulated trucks, delivery trucks, fork lift trucks, mobile lifting equipment, commercial vans and lorries and private vehicles.

Traffic routes, haul roads and passageways should be wide enough and the surfaces suitable for the safe movement of the largest vehicle liable to use them. Allowance should be made for the size and design of

vehicles coming into the premises from outside.

Sharp bends and blind corners should be eliminated as far as possible and, where this is not possible, warning signs and mirrors should be used to reduce the risk of accidents. Traffic routes for heavy traffic should be designed, where possible, to avoid the areas mainly used by pedestrians.

The need for vehicles to reverse when collecting or delivering goods should, where possible, be avoided. Where quarry vehicles, forklift trucks, lorries, vans etc. have to reverse, markings on the ground in the area frequently used for reversing should be provided to aid the driver. Any person giving instructions to drivers should avoid doing so from behind the vehicle. A realistic speed limit should apply to all site vehicles and those making deliveries etc. and an appropriate speed limit should also apply within buildings.

Traffic routes should be suitably designed and maintained for the traffic to be carried -

- ▶ roads or floor surfaces should be constructed and surfaced with suitable material; surfaces should be even and properly drained;
- ▶ excessive gradients should be avoided;
- ▶ routes for pedestrians between levels within buildings should be by a properly constructed stairs, elevators, lifts or suitably constructed ramps or cat-walks;
- ▶ the use of fixed ladders for access should be avoided unless access is not needed very often and no other means is possible.

Where mobile equipment is in use in workrooms traffic aisles should be arranged so as to avoid sharp corners, inclines, steep ramps and narrow passageways. They should be clearly defined, by floor markings if necessary, and be free of obstacles.

Traffic routes must be organised and suitably marked, for example by placing clear directional and control signs as required. Routes, including one-way systems, which minimise reversing, are preferred. Drivers who are not familiar with the quarry/site, need to be given instructions on any restrictions and given clear directions to their destination.

Public Safety

Where vehicles on site cross a footpath or turn onto a public highway, particular consideration must be

given to safeguarding the public. This may involve discussions with the planning and roads authorities and the Garda Síochána.

Visitors to the quarry, such as customers with their own vehicles, members of the public, occasional sub-contractors, An Garda Síochána, delivery drivers, or anyone who has reason to visit the quarry who is driving a vehicle, should be clearly directed to a public parking area and a procedure should be put in place to ensure that there is no (or minimal) interaction with quarry traffic. This can be achieved in a number of different ways which could include:

- ▶ Customer collection areas where the customer's vehicle is loaded;
- ▶ Discourage any non-quarry vehicles entering into the quarry traffic routes;
- ▶ All visitors directed to where they are to travel within the a quarry;
- ▶ Visitors should be encouraged to stay in their vehicles at all times; and
- ▶ Where it is necessary for visitors to get out of their vehicles, they must wear the necessary PPE.

Figure 31: Customer collection area



23. OUTDOOR WORKSTATIONS (Regulation 26)

26. *The operator shall ensure that -*

- (a) *workstations, traffic routes and other areas or installations outdoors that are occupied or used by persons at work in the course of their activities are organised in such a way that pedestrians and vehicles can circulate safely, and*
- (b) *when persons at work are deployed at outdoor workstations, such workstations are arranged so that they, as far as possible -*
 - (i) *are protected against inclement weather conditions,*
 - (ii) *are not exposed to harmful noise levels or to harmful external influences such as gases, vapours or dust, and*
 - (iii) *cannot slip or fall.*

This should be considered in addition to what is set out above in relation to traffic routes, section 22.

When necessary, barriers should be placed outside doorways from buildings giving access to roadways used by vehicles but care must be taken that their positioning does not create a trap point. Suitable pedestrian routes and crossing points should be indicated and marked out.

Pedestrians need to be kept away from vehicles, particularly where vehicles need to turn or reverse. They should use separate traffic routes wherever possible, for example, pedestrian-only areas and safe, designated pedestrian routes. Where this is not possible, measures such as high-visibility clothing and good lighting may be relied on to reduce the risks, along with requirements relating to speed, reversing and visibility.

Where a doorway used by powered vehicles is fitted with a door or curtains, that doorway should not be used by both vehicles and pedestrians unless a clear view is afforded on both sides. Vehicles should be provided with flashing lights, reversing alarms, etc. as an effective means of warning pedestrians of their approach where the driver's view is restricted.

All passageways should be adequately lit, particularly

- a) near buildings
- b) in pedestrian areas
- c) at junctions

- d) where there is regular movement of vehicles and other mobile plant.

Visitors who are unfamiliar with the quarry should be accompanied by a member of staff if they are required to walk through quarry operating areas.

Consideration must be given to the protection of employees employed at outside workstations and who may be exposed to inclement weather and harsh working conditions. These requirements apply to workstations which are intrinsic to the quarrying operation. Examples of these would be drilling activities, blasting operations, crushing and screening plants, workshops, block yards, warehousing, etc. The requirements are almost self-explanatory and existing good standards as reflected in other regulations or codes of practice should be applied.

24. PROTECTION FROM FALLING OBJECTS AND PROVISION OF SAFETY HELMETS (Regulation 27)

27.

- (1) *The operator shall ensure that -*
- (a) *adequate measures are taken to prevent persons at work from being struck by any falling object,*
 - (b) *where feasible, persons are protected by collective methods against falling objects, and*
 - (c) *materials, equipment and other articles are laid out or stacked in such a way as to prevent their collapsing or overturning.*
- (2) *The operator shall ensure that every person under his or her direct control at work at the quarry is provided with -*
- (a) *a suitable safety helmet, or*
 - (b) *other appropriate head protection, that complies with the relevant statutory provisions, unless there is no foreseeable risk of injury to the head.*
- (3) *The operator shall ensure that -*
- (a) *each safety helmet or other head protection provided for use at the quarry is marked so that it may be identified by the person to whom it has been issued, and*

(b) the helmet or other head protection is not issued to any other person unless and until it has been cleaned and disinfected.

- (4) *A person shall not, at a quarry, throw, drop or allow to be shot or ejected downwards any material or object, including waste material, from a height where it is liable to cause injury.*

- (5) *A person who moves materials or objects, including waste materials, from a height at a quarry where they are liable to cause injury, shall lower them so as to avoid injury to persons.*

The safety and health of employees must be primarily safeguarded by measures to eliminate workplace risks at source through technical or organisational means or by providing protection on a collective basis. Collective protective measures protecting numbers of employees must be given priority over individual protection such as PPE.

Ideally, people should not be working in areas where there is a risk from falling objects and, if possible, collective protective measures should be put in place such as exclusion zones where the risk is high by fencing off these areas. Signs must be provided to warn employees entering such areas of the hazards involved.

Generally it is not possible to protect employees at quarries from the risks of falling objects by collective means alone and safety helmets must be provided to and worn by all employees who may be exposed to this risk at any time. Helmets issued need to have a distinguishing mark identifiable to the employee but must not be a mark that might adversely affect the performance of the helmet such as drilled holes, notching of the edges etc. More detailed guidance is provided in the HSA guidance to the General Application Regulations 2007.

Organisational measures should be put in place to ensure articles or materials are not thrown or dropped from a height that might put persons at work at risk of injury.

25. PREVENTION OF DROWNING (Regulation 28)

28.

- (1) *The operator shall ensure that where, at a quarry, there is a risk of a fall from -*
 - (a) *the edge of land adjacent to water,*
 - (b) *a structure adjacent to or above water, or*
 - (c) *a floating platform,**secure fencing is provided near the edge of the land, structure or platform, as appropriate, to prevent such a fall.*
- (2) *To the extent necessary for the access of persons or movement of materials, paragraph (1) does not apply if appropriate precautions are taken, so far as is reasonably practicable, to ensure the safety and health of persons at work.*
- (3) *Without prejudice to paragraph (1), where, in or adjacent to the quarry, there is water into which a person, in the course of his or her work, is liable to fall with risk of drowning, the operator shall ensure that -*
 - (a) *suitable rescue equipment is provided, properly maintained and ready for use,*
 - (b) *arrangements are made for the prompt rescue of any such person who is in danger of drowning, and*
 - (c) *personal flotation devices conforming to European Norm (EN) or, where appropriate, an equivalent standard, are provided and worn at all times by persons at risk at the quarry.*
- (4) *The operator shall ensure that personal flotation devices provided under this Regulation are -*
 - (a) *properly maintained,*
 - (b) *checked before each use,*
 - (c) *inspected in accordance with the manufacturer's instructions, and*
 - (d) *subjected to a thorough examination by a competent person every 12 months.*
- (5) *On the day of an inspection or examination under paragraph (4), the person who carries out the inspection or examination, as the case may be, shall -*
 - (a) *make a report of the results in an approved form,*
 - (b) *sign and date the report, and*
 - (c) *give a copy of the report to the operator.*

These requirements set out the means of preventing drowning at quarries. While this risk exists in most quarries, the majority of drowning at quarries has involved intentional or inadvertent trespass by members of the public. The first part of this regulation makes no reference to work activity and therefore covers all potential drowning of persons at quarries. Operators must consider the particular risks associated with trespass where areas of the quarry are flooded or contain other areas of water such as lagoons and settling ponds. The use of water bodies at quarries by youths or other members of the public for recreation or bathing must be prevented as far as is reasonably practicable by restricting access and the placing of appropriate warning signs.

Figure 32: Warning signs



This regulation requires the operator to provide secure fencing where there is a risk of a fall into water from an edge above, adjacent to or on a structure or platform above or adjacent to water. This requirement will not apply where access by persons or movement of materials is required and other appropriate precautions are taken.

Where there is a risk of persons falling into water and drowning during the course of their work at a quarry, the operator is required to provide;

- ▶ suitable rescue equipment such as lifebuoys, rescue boats etc, properly maintained and ready for use,
- ▶ arrangements for prompt rescue, such as an adequate number of well placed lifebuoys, prohibiting lone working near water, etc.,
- ▶ personal flotation devices, (PFD's) which are properly maintained, checked before use and tested every 12 months, worn at all times by persons at risk.

26. ESCAPE AND RESCUE FACILITIES (Regulation 29)

29. Without prejudice to section 11 of the Act, the operator shall ensure that -
- (a) adequate means of escape and rescue are provided and maintained, so as to enable persons to leave the quarry promptly and safely in the event of danger,
 - (b) adequate means of communication and warning are provided to enable assistance, escape and rescue operations to be launched at once when required,
 - (c) instructions concerning the use of emergency equipment and the action to be taken in the event of an emergency at or near the quarry are prepared,
 - (d) persons at work at the quarry are trained in appropriate action to be taken in the event of an emergency,
 - (e) rescue equipment is provided, maintained in good working condition and kept ready for use at readily accessible, appropriately sited and clearly sign-posted places,
 - (f) emergency routes and exits remain clear and lead by the most direct means to the open air, a safe area or a safe assembly or evacuation point,
 - (g) the number, distribution and dimensions of the emergency routes and exits are appropriate to the use, equipment and dimensions of the quarry and the maximum number of persons that may be present,
 - (h) emergency doors open outwards and are not so locked or fastened that they cannot be easily and immediately opened by any person who may require to use them in an emergency,
 - (i) emergency routes and exits, and the traffic routes and doors giving access to such routes and exits, are free from obstruction so that they can be used at any time without hindrance,
 - (j) emergency routes and exits requiring illumination are provided with emergency lighting of adequate intensity, and
 - (k) specific emergency routes and exits are indicated by signs in accordance with the relevant statutory provisions applying to safety and health signs at work.

The identification of hazards and the assessment of the risks carried out as part of the preparation of the safety statement will have identified hazards that however unlikely to occur would, if they were realised, result in a serious incident or emergency at the quarry, such as a major fire or escape of noxious gases. These could occur from the interaction of chemicals, or a failure in a process, a rupture of a pressure vessel, from inadvertent detonation of explosives or from other sources. This requires the Operator to prepare emergency procedures for the quarry.

In the emergency procedures particular attention should be paid to means of escape from areas such as buildings, rooms, chambers, confined spaces and other areas where there is a significant risk from:

- ▶ fire or explosion;
- ▶ the escape of steam;
- ▶ concentration of noxious gases; or
- ▶ ground collapse, for example at the quarry face, at stockpiles, in stockpile tunnels or tunnels to which people have access in the course of their work.

Means of escape need to be taken into account when designing fixed, temporary or mobile workplaces. Sometimes a second exit may be necessary where highly flammable liquids are used.

Any work in confined spaces should be carried out in accordance with the Health and Safety Authority's **Code of Practice for Working in Confined Spaces**, the code of practice can be downloaded from the HSA website.

Communications

Effective means of communication are important in an emergency, particularly in remote areas and for lone workers. Communication equipment might range from bells/sirens to more sophisticated public address or closed circuit television systems. Risk assessments should indicate the communication systems to be used for lone workers in an isolated area. Radios or telephones can enable rapid communication if they are carefully positioned, although they must not be used close to explosives or where there is a risk of an explosive atmosphere. They may, for example, be fitted to mobile plant or back-up service vehicles, or issued to appropriate individuals.

In most quarries, liaison with the emergency services is helpful. In particular, it is advisable to inform them

in advance of any dangers that might affect their operations, for example the presence of explosives, LPG (Liquefied Petroleum Gas) storage, unstable faces and burning tyres, which may explode.

Well-constructed and maintained roadways allow emergency vehicles easier access. These vehicles are generally made for road use and are not suited to difficult terrain. A quarry vehicle may need to be adapted for use as an emergency vehicle for use on difficult terrain. It is helpful, where feasible, in emergencies to have a person waiting at the quarry entrance to direct the emergency services.

Rescue Equipment

Examples of the types of rescue equipment that may be required include:

- (a) Breathing apparatus;
- (b) first aid equipment (as per First Aid Regulations);
- (c) stretchers;
- (d) ropes;
- (e) ladders (rigid or rope);
- (f) lifting equipment, such as winches, tripods etc.;
- (g) tools, e.g., pickaxe crowbar, shovel, cutters;
- (h) quarry vehicle adapted as a rescue vehicle;
- (i) buoyancy aids, e.g. lifejackets, lifebuoys (rings);
- (j) rescue boats.

It is advisable to liaise with the local emergency services in relation to particular risks that may exist at the quarry.

Training

Most people only need to be able to leave their workplace and go to a designated place of safety in the event of an emergency. Where rescue equipment is provided, enough people should be trained to use it without endangering themselves or others. This will include sufficient number of persons receiving training in first aid and the use of fire fighting equipment and in arranging liaison with the emergency services. The number of persons trained in First Aid is dependent on the size of the operation and on the nature of the operations carried out at the quarry but there should always be at least one trained first aider present at the quarry and the operator is required to ensure that there is sufficient first aid equipment to enable first aid to be rendered.

The operator must ensure that enough trained personnel are provided to administer first aid in

accordance with requirements of the Safety, Health and Welfare at Work (General Application) Regulations, which are a minimum of one if risk assessment so specifies or one if risk assessment so specifies or one for up to 150 employees and a minimum of two for above that.

27. SAFETY DRILLS (Regulation 30)

30. *The operator shall ensure that safety drills are held at the quarry at regular intervals for persons at work there for the purposes of -*

- (a) *training the persons who work at the quarry in the appropriate actions to be taken in an emergency, including, where appropriate, the correct use, handling and operation of emergency equipment, and*
- (b) *training and checking the skills of such persons to whom specific duties involving the use, handling and operation of such equipment have been assigned in the event of an emergency.*

The risk assessment should identify the type of emergencies which may occur and, consequently, the safety drills which will be of value. The people involved in such drills, the areas covered and the number of safety drills that are needed should be decided based on these assessments.

Safety drills help ensure that people know what to do in an emergency. In particular, they help those likely to be involved in escape and rescue operations familiarise themselves with procedures, equipment and assembly points. In certain situations it may be appropriate to carry out safety drills in conjunction with the emergency services. This will aid the training and checking of skills in readiness for possible emergencies.

28. FIRE AND EXPLOSION HAZARDS (Regulation 31)

31.

- (1) *This Regulation applies without prejudice to section 11 of the Act and the Fire Services Acts 1981 and 2003 (No. 30 of 1981 and No.15 of 2003).*
- (2) *The operator shall ensure that -*
 - (a) *no person at work at the quarry uses a naked flame or carries out any work that could give rise to a risk of an unintended*

fire or explosion, unless sufficient measures to prevent such a fire or explosion are taken, and

- (b) no person smokes or carries a lighted pipe, cigar or cigarette in any part of the quarry where there is a risk of fire or explosion.*
- (3) The operator, depending on the features of the quarry, the dimensions and use of rooms, the on-site equipment, the physical and chemical properties of the substances present and the maximum potential number of persons present at work, shall provide or cause to be provided at the quarry an adequate number of -*
 - (a) appropriate fire-fighting devices, and*
 - (b) where required, fire detectors and alarm systems.*
- (4) The operator shall ensure that -*
 - (a) fire-fighting devices, fire detectors and alarm systems are regularly checked and properly maintained,*
 - (b) appropriate tests and fire drills take place at regular intervals,*
 - (c) non-automatic fire-fighting equipment is easily accessible, easy to use and, where necessary, protected from potential damage, and*
 - (d) fire-fighting equipment is indicated by signs in accordance with the relevant statutory provisions applying to safety and health signs at work.*

Hot work should not be permitted near closed vessels which contain or have contained flammable substances, except under a permit to work system. Even a trace of the flammable substance may create enough flammable vapour to cause a substantial explosion.

Hot work needs also to be prohibited on closed pressurised systems which could explode or fail as a result of heat. This includes tyres and wheels, which are often contaminated with grease or oil and create hazards as regards both pressure and flammable substances.

The operator must ensure that appropriate fire fighting equipment and where necessary fire detection and alarm systems are provided, indicated by signage, tested and maintained.

29. EXPLOSIVE OR HARMFUL ATMOSPHERES (Regulation 32)

32.

- (1) Where there is a potential for harmful or explosive atmospheres to be present at the quarry, the operator shall ensure that-*
 - (a) steps are taken in order to determine whether potentially harmful or explosive substances are present in the atmosphere and, where such substances are present, the concentration of such substances in the atmosphere is measured,*
 - (b) automatic devices are provided that are designed to -*
 - (i) monitor continuously the concentration of explosive or flammable gases in the atmosphere,*
 - (ii) trigger an alarm if such concentration reaches a dangerous level, and*
 - (iii) cut off power to any plant that, because of the concentration of such gases in the atmosphere, gives rise to a risk to the safety and health of any person,*
 - (c) where devices are provided in accordance with subparagraph (b)(i), a record of the levels of concentration of such gases in the atmosphere is made at such intervals as are specified in the safety statement,*
 - (d) at any place in the quarry where there is a risk of the occurrence or accumulation of an explosive atmosphere, all necessary measures are taken in order -*
 - (i) to prevent such occurrence and accumulation, or*
 - (ii) where this is not practicable, to prevent the ignition of such an atmosphere, and*
 - (e) at any place in the quarry where there is a risk of the occurrence or accumulation of a substance harmful to health in the atmosphere, appropriate measures are taken in order to -*
 - (i) prevent such occurrence and accumulation or, where this is not practicable,*
 - (ii) extract or disperse that harmful substance in such a way that persons are not placed at risk.*

- (2) *When persons at work are present in a particular place in the quarry where they are exposed to a substance in the atmosphere that is, or may be, harmful to health, the operator shall ensure that -*
- (a) *appropriate and sufficient breathing and resuscitation equipment is -*
 - (i) *available,*
 - (ii) *suitably stored, and*
 - (iii) *maintained,*
 - (b) *a sufficient number of persons trained in the use of such equipment are present, and*
 - (c) *where harmful substances accumulate or may accumulate in the atmosphere, appropriate measures are taken to ensure -*
 - (i) *their suppression at source,*
 - (ii) *their extraction at source,*
 - (iii) *their removal, or*
 - (iv) *the dilution of accumulations of such substances, in such a way that persons are not at risk.*

Work in most quarries is not likely to create a significant risk of an accumulation of explosive or flammable gases. If the risk is negligible then no action needs to be taken. There are circumstances, however, in which such a risk could arise, for example, as a result of landfill gases from a neighbouring waste disposal site or in a confined space. Any possibility of significant concentrations of flammable gases at a quarry needs to be carefully assessed and measurements taken to determine typical concentrations. The action required to comply needs to be recorded in the safety statement.

Where flammable gases are likely to be found at above 25% of their lower explosive limit precautions need to be specified in the safety statement.

Alarms, where fitted, should be triggered as soon as the concentration of flammable gas exceeds 25% of its lower explosive limit, i.e. 1.25 % CH₄ (Methane) by volume. Electrical and any other equipment, which is liable to be exposed to flammable vapours, must be suitable for use in such conditions. The Safety, Health and Welfare at Work (General Applications) Regulations 2007 and the EU Commission guidance on the ATEX Directive may provide useful information in this area but do not specifically apply to quarrying. They would be applicable to factory situations at the quarry which are outside of the area covered by the

Quarries Regulations but within the quarry boundary. Power cut-off devices are not an alternative to using equipment designed for use in a flammable atmosphere. They are only appropriate where the risk of exposure to flammable vapours is low and the act of cutting-off the power would not in itself create a risk of ignition, for example, from an electrical spark.

30. LIGHTING (Regulation 33)

33. *The operator shall ensure that -*
- (a) *the quarry is provided throughout with lighting capable of supplying illumination sufficient to ensure the health and safety of persons therein,*
 - (b) *workstations, as far as possible -*
 - (i) *receive sufficient natural light, and*
 - (ii) *bearing in mind the climatic conditions, are equipped with artificial lighting adequate for the protection of the safety and health of persons at work,*
 - (c) *lighting installations in rooms containing workstations and in passageways are placed in such a way that the type of lighting provided does not present a risk of accident to persons at work, and*
 - (d) *every part of the quarry in which a person is likely to be exposed to risks in the event of the failure of artificial lighting is provided with emergency lighting of adequate intensity and, where that is not possible, persons at work in that place are provided with an appropriate personal lamp.*

Lighting a quarry is much more difficult than lighting a flat area because of the many uneven surfaces and the consequential deceptive effects of shadows even in and around the processing areas. Emergency lighting is required where work continues after dark and safe evacuation is not possible without artificial lighting. Where lighting is provided by independently powered lighting towers, and failure of any one tower would still leave enough light to enable people to leave the area safely, no further emergency lighting needs to be provided.

Lights provided on vehicles should be sufficient to enable them to be driven safely, but additional lighting may be required for manoeuvring operations such as reversing or tipping.

Where a person is exposed to risks by the failure of artificial lighting, emergency lighting of an adequate intensity should be provided where practicable. Where this is not possible, a personal lamp should be provided. The safety of security staff and others who have to move around the quarry at night must be ensured by an appropriate combination of floodlights and torches.

Figure 33: Operating a quarry using artificial lighting



31. PREVENTION OF UNAUTHORISED ENTRY (Regulation 34)

34. The operator shall ensure that -

- (a) quarry boundaries are signposted and laid out so as to be clearly visible and identifiable,
- (b) safe means of access and egress at the quarry are
 - (i) provided and maintained, and
 - (ii) where appropriate, indicated,
- (c) adequate precautions are taken to protect persons present at, or in the vicinity of, the quarry from risks that may arise from quarrying operations, and
- (d) adequate precautions are taken to prevent unauthorised entry to the quarry including, where appropriate, the provision of barriers.

Employers and the self-employed have a general duty, under Section 12 of the Safety, Health and Welfare at Work Act 2005 to ensure they conduct their undertaking in such a way to ensure, so far as was reasonably practicable, that persons not in their employment who may be affected are not exposed to risks to their safety and health. This, in respect of quarry operators includes ensuring, where

appropriate, that a barrier suitable for the purpose of discouraging trespass is placed around the boundary of the quarry and is properly maintained. In this context, trespass means entry to the quarry without the operator's express or implied permission or some legal justification.

Barriers are appropriate where it is reasonably foreseeable that members of the public, including children, are likely to trespass and could suffer injury if they did so. There is a significant risk of injury or death to trespassers at most quarries. Barriers should always be provided at quarry boundaries which are near to schools, colleges, shops or significant numbers of homes. The provision of barriers needs to be considered as part of the risk assessment process, and the findings of the assessment included in the safety statement.

The type of barrier depends on the risks. Where the risk of public access is low, hedges, stock proof fencing, bunds, trenches or mounds may be enough. In some circumstances where the risk of trespass is high sophisticated metal paling fences will be required.

Trespassing should be actively discouraged by signage and security measures, incidents reported and appropriate action taken to prevent further trespass.

Records must be kept to show that barriers have been appropriately inspected and repaired in accordance with the scheme of inspection at the quarry.

Even high quality fencing will also require periodic checking to ensure it is in good condition and preventing inadvertent access as can be seen in figure 34 below.

Figure 34: Protecting the boundary of a quarry from inadvertent access



32. APPLICATION OF THIS PART (Regulation 35)

Definition of "place of work" (Part 4).

35. In this Part "place of work" means -

- (a) premises at the quarry housing workstations, and
- (b) other premises at the quarry to which persons at work have access for the purpose of the immediate and ancillary activities and installations of the quarry, including premises providing accommodation, rest and sanitary facilities.

The requirements of this part apply to all places of work at the quarry which are located within a premises or buildings. This particular definition of "place of work" is for this Part only and covers not only the place where work actually takes place but also rest areas, toilets, changing rooms etc. The broader definition found in the 2005 Act applies where the term is used elsewhere.

33. STABILITY AND SOLIDITY (Regulation 36)

36. The operator shall ensure that a place of work, whether temporary or permanent, has a structure and solidity appropriate to its use, and -

- (a) has been designed and constructed, and
- (b) is operated, supervised and maintained, so as to withstand the environmental forces anticipated and to be safe and without risk to health.

The operator must be satisfied that the floors, walls etc. are able to support both the weight of equipment and the pressures of additional forces which its use imposes on the structure.

The structure's materials, where possible, should also be suitable for the work undertaken so that over time it does not fail, for example, walls cracking due to vibration from blasting, floors rotting due to moisture or corrosion of structural steel supports. Where such risks have been identified ongoing periodic examination will be necessary to detect any signs of deterioration.

In some workplaces there will be risks to the structure from impact damage caused by moving vehicles and measures need to be taken to protect vulnerable areas and to repair any damage before it poses a hazard to safety.

The installation of new equipment in existing buildings may require an analysis to determine if structural changes are necessary.

If cracks occur in any structure they need to be investigated to ascertain if there is a risk to safety.

34. FLOORS, WALLS AND CEILINGS OF ROOMS (Regulation 37)

37.

(1) The operator shall, in respect of a place of work, ensure that -

- (a) floors -
 - (i) have no dangerous bumps, holes or slopes, and
 - (ii) are fixed, stable and not slippery,
- (b) workstations are adequately insulated, having regard to the type of work activity involved and the physical activity of the persons at work, and
- (c) surfaces of floors, walls and ceilings are such that they -
 - (i) can be cleaned, and are cleaned, and
 - (ii) where appropriate, refurbished to an appropriate standard of hygiene.

(2) The operator shall ensure that transparent or translucent walls, and in particular, glass partitions, in a place of work or in the vicinity of outdoor workstations and traffic routes, are -

- (a) clearly indicated, and
- (b) made of safety material, or are shielded from such places or routes, in order to prevent persons from coming into contact with such walls or partitions, or being injured in the event of such walls or partitions shattering.

The surfaces of floors and traffic routes should be free from any hole, slope or uneven or slippery surface which is likely to cause:

- (a) a person to slip, trip or fall,
- (b) a person to drop or lose control of anything being lifted or carried, or
- (c) instability or loss of control of vehicles or their loads (or both).

Slopes should not be steeper than necessary. Moderate and steep slopes should be provided with a secure handrail, where necessary.

Floor surfaces which are likely to become wet or to be subject to spillages should be of a type which does not become unduly slippery. Where there is likely to be danger, protection should be provided, for example through protective footwear, slip resistant floor surfaces, barriers around areas being cleaned, proper cleaning techniques and adequate maintenance.

The report "Safer surfaces to walk on - reducing the risk of slipping", published by the UK Construction Industry Research and Information Association (CIRIA), provides useful information for designers and building maintenance managers.

Floors, ceilings and interior walls should be painted, tiled or otherwise treated so that they can be kept clean. The surface treatment should be renewed when it can no longer be cleaned properly. Absorbent floors, such as untreated concrete or timber, which are likely to be contaminated by oil or other substances which are difficult to remove, should be sealed or coated, for example, with a suitable non-slip floor paint. Interior walls, floors, ceilings and work surfaces must be cleaned at suitable intervals. The intervals will depend on the type and level of work activity and the frequency of use. Cleaning should be carried out by an effective and suitable method and without creating a health or safety risk for employees.

For some places of work, the selection and cleaning of floors and walls may also be subject to food hygiene requirements, set by the Food Safety Authority of Ireland.

Buildings at quarries can have roofs that contain fragile materials. Roofs containing fragile materials include the following:

- ▶ profiled plastic cladding,
- ▶ glass reinforced plastic (GRP) daylight sheets,
- ▶ asbestos cement sheets,
- ▶ fibre cement sheets (non-asbestos),
- ▶ glass-wired or plain,
- ▶ light gauge steel sheets,
- ▶ other fragile materials used for roofing.

Access to roofs is often a feature of maintenance work and the provisions of Part 4 of the General Application Regulations 2007 relating to work at height will be relevant.

Persons at work may not be allowed to –

- ▶ pass across or work on or from a fragile surface where it is reasonably practicable to carry out work safely without their doing so,
- ▶ enter onto any roof which incorporates fragile material and which would be liable to fracture under weight, unless protective measures are taken, e.g. use of ladders, crawling ladders, crawling boards or duck boards,
- ▶ work near, or to pass by, fragile parts of a roof unless suitable protective measures are taken, e.g., guard rails, coverings or other suitable means to prevent them stepping on or falling through the roof should they lose their balance.

Prominent warning notices must be posted where there is access to, or where any person at work passes across or near, any fragile roof. In addition, a verbal warning must be given to any employees who may require such access.

A translucent wall is one that is semi-transparent. The first requirement in relation to a translucent wall is to ensure that persons will be able to note the presence of a transparent wall and not confuse it for an opening through which they expect to pass.

Transparent or translucent walls and partitions should be made of materials which are safe or they should be adequately protected against breakage, particularly where any part of the transparent or translucent surface is at waist level (800 mm from floor level) or below.

Detailed guidance related to glazing and human impact can be found in BS 6262-4:2005; "Glazing for buildings-code of practice for safety related to human impact".

As an alternative to the use of safety materials, transparent or translucent surfaces may be adequately protected against breakage. This may be achieved by means of a screen or barrier which will prevent a person from coming into contact with the glass if he or she falls against it.

A transparent or translucent surface should be marked, where necessary, to make it apparent. Where it is needed, marking may take any form (for example coloured lines or patterns) provided that it is conspicuous and at a conspicuous height.

35. ROOM DIMENSIONS AND AIR SPACE IN ROOMS ETC (Regulation 38)

38. *The operator shall, in respect of a place of work, ensure that -*

- (a) *rooms have sufficient surface area, height and air space to allow persons at work to perform their work without risk to their safety, health or welfare, and*
- (b) *the dimensions of the free space at the workstation allow persons at work sufficient freedom of movement and enable them to perform their work safely.*

Inadequate space, overcrowding and uncomfortable conditions are to be avoided if employees are to work safely and without risk to health. Because of the variety of workplaces it would be very difficult to specify the space which should be provided for every situation. The figures below should be used in the places of work mentioned and also as a guide for comparable places of work. Guidance to the Building Regulations and codes issued by professional bodies should be referred to.

When calculating the allocation of space available it should be remembered that, in general, inadequate space or overcrowding can increase the risk of accidents. Adequate space around the workstation is necessary to provide suitable access and egress for the general wellbeing of the person at work, to facilitate maintenance, adjustment and cleaning of equipment and to provide space for work in progress.

The following should be used as a guide for factories, offices and other similar workplaces:

In calculating the allocation of space a reasonable approach should be taken as regards discounting any large spaces taken up by unusual fittings, furniture, machinery etc. In a room containing a counter, the space up to and under it should be included when calculating the space available for each person behind the counter

Office work or similar

In offices, 4.65 square metres should be the minimum amount of floor space allowed for every person employed in any room, including the area occupied by the office desk and chair but excluding filing cabinets and other office furniture.

Places of work other than in an office or similar

At least 11.3 cubic metres should be provided for each person at work in a room at any one time. When calculating the volume, no space more than 4.3 metres from the floor should be taken into account.

Sufficient space should be available to employees at their workstations to carry out their work safely and comfortably.

Each workstation should allow the employee adequate freedom of movement and the ability to stand upright. When work must be carried out in cramped conditions, the duration should be kept as short as possible and sufficient space provided nearby to allow for freedom of movement

36. WINDOWS AND SKYLIGHTS (Regulation 39)

39. *The operator shall, in respect of a place of work, ensure that -*

- (a) *windows, skylights and ventilation devices -*
 - (i) *that are meant to be opened, adjusted or secured are designed so that these activities can be carried out in a safe manner, and*
 - (ii) *are not positioned so as to constitute a hazard to persons at work when open, and*
- (b) *windows and skylights can be cleaned without risk.*

It should be possible for employees to open, close, adjust or secure windows, skylights and ventilators in a safe manner. Where necessary, suitable equipment should be available to employees for opening/closing windows from floor level or from a secure platform, without having to use chairs or tables, etc..

Windows, when open, should be such that they do not project into passageways at a height where they are liable to be struck by passers-by nor should they be located where persons could accidentally fall through them.

The age, design and location of a building will determine the most appropriate method for cleaning buildings. Options include:

- ▶ Self-cleaning glass
- ▶ Windows that can be safely cleaned on both sides from within the building

- ▶ Permanent walkways
- ▶ Suspended cradles
- ▶ Rope access
- ▶ Mobile elevated working platforms
- ▶ Tower scaffolding
- ▶ Long pole cleaning systems.

In some instances the use of ladders or safety harnesses may be acceptable but their use should be reviewed in the context that there may be safer options.

BS 8213-1:2004 provides useful information when considering access options for window cleaning.

37. DOORS AND GATES (Regulation 40)

40. The operator shall, in respect of a place of work, ensure that -

- (a) the position, number and dimensions of doors and gates, and the materials used in their construction, are determined by the nature and use of the rooms or areas concerned,
- (b) transparent doors are appropriately marked at a conspicuous level,
- (c) swing doors and gates are transparent or have see-through panels,
- (d) if transparent or translucent surfaces in doors and gates are not made of safety material and there is a danger that persons at work may be injured in the event of a door or gate shattering, the surfaces are protected against breakage,
- (e) sliding doors are fitted with a safety device to prevent them from being derailed or falling over,
- (f) doors and gates opening upwards are fitted with a mechanism to secure them against falling back,
- (g) doors forming part of escape routes are -
 - (i) appropriately marked,
 - (ii) possible to open from the inside at any time without special assistance, and
 - (iii) possible to open when the place of work is occupied,
- (h) doors for pedestrians are provided in the immediate vicinity of any gates intended essentially for vehicle traffic, unless it is safe for pedestrians to pass through and such doors are clearly marked and left permanently unobstructed,

- (i) mechanical doors and gates function in such a way that there is no risk of accident to persons at work, are fitted with easily identifiable and accessible emergency shutdown devices and, where they open automatically in the event of a power failure, it is also possible to open them manually, and
- (j) where chains or similar devices are used to prevent access to any place, these are clearly visible and appropriately identified by signs denoting any prohibition or warning.

Doors and gates installed in places of work should be suitable for the number of persons employed and the nature of the work carried on. Factors which should be taken into account are the traffic routes used by pedestrians and vehicles, access for people with disabilities, requirements in the event of an emergency, visibility issues, nature of vehicular traffic, the numbers of employees requiring access or egress, the size and quantity of material moving in and out of the place of work and the effort required to open/close gates.

In some instances doors may require a certain fire rating to maintain a secure means of escape in case of fire.

The Building Regulations Technical Guidance Document "B" Fire Safety sets out a range of criteria that will influence the siting of doors.

So as to prevent employees walking through them, the markings on transparent doors should be conspicuous and not easily removable.

The Building Regulations Technical Guidance Document "M" Access for People with Disabilities advises that permanent markings be placed 1,200 to 1,500 mm above finished floor level.

Transparent or translucent surfaces in doors and gates should be made of materials which are safe or they should be adequately protected against breakage, particularly where any part of the transparent or translucent surface is at shoulder level (1,500 mm from floor level) or below.

BS 6262-4:2005 on glazing in buildings may be a useful reference.

Sliding doors should have effective means to prevent them from coming off their tracks. They should have a retaining rail to prevent them falling should their

suspension system fail or the rollers leave the track.

Upward opening doors should be fitted with an effective device, such as a counter balance or ratchet mechanism, to prevent them falling back in a manner likely to cause injury.

Where the speed and/or volume of traffic creates a risk to the safety of persons, separate pedestrian and vehicular routes should be provided at any entrance or exit point in or from a place of work. Account should be taken of the greatest volume of traffic, the number of persons likely to use the route at any given time, the width of the gateway and the degree of visibility from both sides.

Traffic control will be necessary to secure pedestrian safety. The boundaries of pedestrian and vehicular routes should be clearly defined, for example, by the use of raised footpaths or kerbs.

In respect of frequently-used doorways fitted with plastic curtains, unless the doorway is wide enough to facilitate the safe passage of both pedestrians and vehicles on clearly marked routes, alternative access arrangements for pedestrians should be provided. Plastic curtains become opaque over time from wear and tear.

Power operated doors and gates should be designed, installed and maintained to prevent injury as a result of being struck by the door or gate or being trapped between parts of it or between it and a wall or floor. Some examples of safety devices for controlling mechanical doors and gates are as follows:

- ▶ a sensitive edge or other suitable detector and associated trip device which is designed to stop, or stop and reverse, the motion of the door when obstructed,
- ▶ devices which limit the closing force to ensure that it is insufficient to cause injury if a person is trapped,
- ▶ an operating control which must be held in the operating position (hold to run) during the whole of the closing motion. This will only be suitable where the risk of injury is low and the speed of closure is slow. This type of control, when released, should cause the door to stop or reopen immediately and should be positioned so that the operator has a clear view of the door throughout its movement.

Power operated doors and gates should have a readily identifiable and accessible control switch or device so that they can be stopped quickly in an emergency.

A risk assessment should be carried out to address potential nip and crush hazards relating to the operation of power operated doors and gates and appropriate safety devices installed to ensure the door/gate cannot fall or crush someone during its operational movement. The Health and Safety Authority have prepared **Guidelines on the Safety of Powered Gates** that are available on the HSA website.

Operators need to determine if a mechanical door/gate is, or is likely to be used as an emergency exit. If it is not designed to open automatically in the case of power failure then the means or tools necessary to open it manually must be readily available. In the event of the power supply being restored, there should be no danger to persons using tools to open a door.

Practice in opening such doors should form part of the programme for fire or emergency evacuation drills.

38. VENTILATION (Regulation 41)

41. *The operator shall, in respect of a place of work, ensure that -*
- (a) *steps are taken to ensure that there is sufficient fresh air in enclosed rooms, having regard to the working methods used and the physical demands placed on the persons at work,*
 - (b) *where a forced ventilation system is used, it is maintained in good working order,*
 - (c) *any breakdown in a forced ventilation system is indicated by a control system, where this is necessary for the health of persons at work,*
 - (d) *where air-conditioning or mechanical ventilation installations are used, they operate in such a way that persons at work are not exposed to draughts that cause discomfort or ill health, and*
 - (e) *any deposit or dirt likely to create danger to the health of persons at work by entering into the atmosphere is removed without delay.*

In most cases the natural ventilation provided through windows and doors will be adequate. In cases where, for instance, there are high dust levels or high temperatures or where the place of work is isolated

from the outside air, mechanical or forced ventilation may be necessary.

The provision of natural or forced ventilation will depend on -

- (a) the processes, materials and substances which are liable to contaminate the atmosphere, released heat or humidity,
- (b) the design of the building,
- (c) the actual volume of the place of work itself,
- (d) the number of occupants,
- (e) the physical activity of the occupants,
- (f) the location of a workstation within a building.

Mechanical ventilation systems should be maintained in good working order as part of a plant maintenance system.

The requirement for a device to give warning of breakdowns applies where necessary for reasons of safety and health. It could apply particularly to "dilution ventilation" systems used to reduce concentrations of dust or fumes in the atmosphere. It could also apply to any other situation where a breakdown in the ventilation system would be likely to result in harm to employees.

The system should be designed so that the breakdown is readily detected by those liable to be affected. Alarms in rarely visited plant rooms would not be adequate.

Draughts may be caused by inadequate design or control of the ventilation system or poor workstation layout arrangements. The sensation of draughts is related to air speed and temperature, a person's activity and level of clothing. It can also be related to the sensitivity of the individual concerned.

Systems should be free from any substance or organism which may contaminate the air passing by it thereby affecting the safety and health of employees. Hazards may arise from spillages of work-related materials, bird/bat droppings near air intakes or the growth of microbial contamination in ductwork. Detailed advice on the cleaning of ventilation systems has been published by a number of bodies including the Chartered Institution of Building Services Engineers (CIBSE)

39. TEMPERATURE IN ROOMS (Regulation 42)

42. *The operator shall, in respect of a place of work, ensure that -*

- (a) *during working hours, the temperature in rooms containing workstations is suitable for the persons at work, having regard to the working methods being used and the physical demands placed on them,*
- (b) *the temperature in rest areas, rooms for duty staff, sanitary facilities, canteens and first aid rooms is appropriate to the particular purpose of such areas, and*
- (c) *in relation to windows, skylights and glass partitions, excessive effects of sunlight are avoided, having regard to the nature of the work and the characteristics of the place of work*

The temperature in rooms in which employees work must be adequate having regard to:

- ▶ the indoor or special work clothing normally worn by the employees,
- ▶ the physical activity involved in the work,
- ▶ other elements of the thermal environment, such as radiant heat, humidity and air movement,
- ▶ the need for any special conditions arising from, or required for, the work being carried out such as heat, cold, humidity etc.

In cases where it is difficult to maintain an adequate overall temperature, it may be necessary to provide effective local heating, protective clothing or cooling at individual workstations.

Care needs to be taken with temporary heaters so as to prevent burns from contact with hot surfaces. No heating method should be employed which results in the escape into the air of any workroom of any fume of such character and to such extent as to be likely to be injurious or offensive to employees therein.

The fact that a maximum temperature has not been specified in the Regulations does not mean that any temperature is acceptable. At high or uncomfortable temperatures, especially when not caused by temporary weather conditions, a means of cooling should be provided.

The determination of appropriate temperatures is addressed in ISO standard 7730 –

“Ergonomics of the thermal environment - Analytical determination and interpretation of thermal comfort using calculation of the PMV and PPD indices and local thermal comfort criteria” which is available as an Irish standard IS EN ISO 7730:2005. This is a complex document most likely to be used at the design stage or during a technical investigation of a complaint.

It is suggested that for most people an acceptable temperature for office work lies within the range of 18° to 23° C. Recommendations for different building uses are available in guidance from CIBSE.

Advice on dealing with heat and cold stress is available from the American Conference of Governmental Industrial Hygienists (ACGIH) or the British Occupational Hygiene Society.

Workers are entitled to have some means readily available to them to measure the temperature. In practice, this means that if an employee wants to measure the temperature there will be a thermometer readily available.

In parts of the place of work other than workrooms, such as sanitary facilities or rest facilities, the temperature should be reasonable in all the circumstances including the length of time people are likely to be there. Changing rooms and shower rooms should be adequately heated.

Excessive heat from the sun shining through windows, skylights or glass partitions must be avoided. This can be achieved by various means including internal blinds, external blinds, use of low-emissivity glass, white-washing of windows etc.

The ACGIH recommend special protection of the hands to maintain manual dexterity and prevent accidents if fine work has to be performed with bare hands for more than 10 to 20 minutes in an environment below 16° C. Clearly, the precautions must take account of the work hazards, i.e. gloves may be appropriate for some applications but not others.

40. APPLICATION OF PART 5 (Regulation 43)

43. *This Part shall apply to the storage, transport, use and disposal of explosives at a quarry.*

The availability of commercial explosives is regulated under the Explosives Act 1875 and associated Explosives Regulations. Explosives are strictly controlled and a person may not import, store or manufacture explosives without a license issued by the Department of Justice, Equality and Law Reform. Transport and sale of explosives is also controlled by detailed regulations.

Explosives in relation to the Explosives Act 1875 include:

- ▶ commercial or industrial explosives (such as detonators, boosters, detonating cord, ANFO and cartridged explosives)
- ▶ propellants (such as shooter's powder, black powder)
- ▶ pyrotechnics (such as marine distress flares, industrial pyrotechnic cartridges and fireworks)

Certain substances such as emulsion explosive matrix, ammonium nitrate, sodium chlorate, potassium nitrate and sodium nitrate also come under the control of the explosives regulations, as they are deemed to be explosives for the purposes of the Explosives Act.

This part deals with the safe use of explosives at a quarry. It does not deal with issues around the importation of commercial explosives, granting of blasting permits, the transport of explosives to or from the quarry or issues in relation to security. These matters are the remit of other departments and/or agencies.

The operator's key responsibility regarding the use of explosives, as in relation to other risks, is to ensure that all work with explosives is properly planned, managed, co-ordinated and supervised. The duties placed on the operator reflect this. This is the case whether shotfiring operations are undertaken by a quarry employee or by a specialist blasting contractor.

41. APPOINTMENT OF EXPLOSIVE SUPERVISORS, SHOTFIRERS AND STOREKEEPERS (Regulation 44)

44.

- (1) *The operator shall -*
- (a) *appoint one or more competent persons as explosives supervisors at the quarry and obtain confirmation of acceptance of such appointments in writing,*
 - (b) *ensure that, at any given time, there is only one person acting as the explosives supervisor at the quarry,*
 - (c) *appoint one or more competent persons as shotfirers and trainee shotfirers at the quarry,*
 - (d) *appoint, where necessary, one or more competent persons as storekeepers to ensure the safe storage and transport of explosives at the quarry, and*
 - (e) *ensure that a record of the appointment at the quarry of any explosives supervisor, shotfirer and storekeeper is kept at the quarry or some other suitable place for the period of his or her appointment and for 3 years following the termination of his or her appointment.*
- (2) *Nothing in these Regulations shall prevent a person appointed as quarry manager under Regulation 10(1)(a) from being appointed as explosives supervisor or shotfirer, or both, under this Regulation, provided that he or she is competent to discharge those functions.*

Appointments and authorisations

The shotfiring rules and procedures at the quarry must set out arrangements for the appointment of explosive supervisors, shotfirers, trainee shotfirers, other persons such as sentries and, where appropriate, storekeepers for work with explosives at the quarry. The operator, or the blasting contractor if there is one, may make these appointments and authorisations depending on what is required by the shotfiring rules. All such appointments must be in writing and records of such appointments kept.

41.1 Explosives Supervisor

There is a requirement on the Operator to appoint an explosives supervisor who holds an appropriate Quarry Skills Certification Scheme registration card. The explosives supervisor is the person in overall day-to-day charge of work with explosives at a quarry. Provided the individual is competent the explosives supervisor can be the quarry manager, another manager or supervisor on site, the shotfirer or a blasting contractor, one of the contractor's employees or an outside consultant.

The operator must be satisfied that an explosives supervisor has sufficient practical and theoretical knowledge and experience for the work he or she is expected to do. To obtain the necessary theoretical knowledge, an explosives supervisor needs as a minimum to have successfully completed a course of training covering:

- (a) blast calculation and design;
- (b) ground vibration and air blast overpressure; and
- (c) shotfiring.

A quarry may require more than one explosives supervisor to cover all the work, for example, where blasting takes place on several shifts or where a blasting contractor is appointed and a number of their representatives are authorised to be the explosives supervisor at the quarry. If this is necessary for the working of the quarry:

- (a) only one person may act as the explosives supervisor at any one time;
- (b) all explosives supervisors must be familiar with the shotfiring rules and the site, as far as that relates to the safe use of explosives; and
- (c) there needs to be good communication and co-ordination between them, for example, to deal with any hand-over or maintenance issues.

41.2 Appointment of Shotfirer

The operator must ensure that shotfiring operations are carried out by a competent shotfirer or by a trainee shotfirer acting under the close personal supervision of a shotfirer.

The procedure for appointing shotfirers is required to be detailed in the Shotfiring Rules and a record of the appointment is required to be kept at the quarry for at least 3 years after that shotfirer ceases shotfiring operations at that quarry. Where a blasting contractor

is to provide the shotfirer then each shotfirer they intend to use must be duly authorised. The operator should also take reasonable steps, such as obtaining a relevant career history, to ensure that the shotfirer is competent and has relevant and recent experience.

Training of shotfirers

All shotfirers must possess sufficient practical and theoretical knowledge and experience to perform their full range of duties. Shotfirers should not be appointed unless they have successfully completed a recognised course of training. A trainee shotfirer must work under the personal supervision of an experienced shotfirer, until the necessary competence has been acquired and demonstrated.

41.3 Blasting Contractors

The operator may appoint a blasting contractor to carry out some or all of the explosives work including fulfilling the role as explosives supervisor, shotfirer etc. The operator is, nevertheless, always responsible for the overall management of the quarry and the safe transport, use, security and disposal of explosives at the quarry. The operator is similarly responsible for the shotfiring rules, and blast specifications, even if the explosives supervisor, a contractor or outside consultant draws them up. Although the legal duties relating to explosives are placed on the operator, the blasting contractor also has a legal responsibility to ensure compliance with the relevant Regulations.

Figure 35: Survey instruments

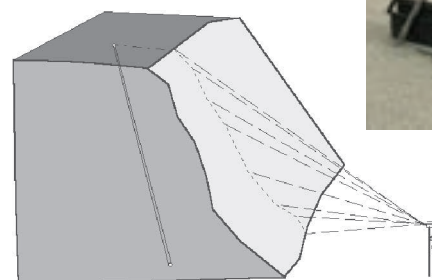

42. STORAGE, TRANSPORT, USE AND DISPOSAL OF EXPLOSIVES (Regulation 45)

45. The operator shall ensure that -

- (a) so far as is reasonably practicable, all explosives are stored, transported, used and disposed of safely and securely,
- (b) operations involving the storage, transport, use or disposal of explosives are carried out by, or under the close personal supervision of, persons appointed under Regulation 44,
- (c) such facilities and equipment as are necessary to enable shotfiring operations to be carried out safely are provided,
- (d) any vehicle that is provided for use in relation to shotfiring operations is safe for use and so marked during such use as to be readily identifiable from a distance,
- (e) detonators are stored and transported in separate containers from other explosives, and
- (f) explosives are kept at all times in a locked explosives store or under the close supervision of a suitable person.

42.1 Custody of Explosives

Explosives must be taken into custody or issued only to an authorised person, such as the shotfirer or trainee shotfirer who is under the direct supervision of a shotfirer. They must remain under the control of such a person at all times. Detonators must be stored and transported in separate containers from other explosives.

Containers for detonators must be fitted with secure locks. Electric detonators must be stored so that they are electrically isolated, with no part of the detonator or lead wires exposed to conducting material. The container must be lined with shock absorbing, anti-static material, kept clean and used only for detonators. Containers should be unlocked for as short a time as possible; only while detonators are actually being inserted or removed. Other explosives must be carried in the manufacturer's packaging or container before use.

Where deliveries of explosives (including detonators) are made directly to the blast site, the shotfirer needs to check the delivery note to ensure that the quantities

are correct, sign for them and ensure that they are not left unattended.

The detonators must be transferred to suitably constructed detonator containers as soon as possible. To enable accurate record keeping, the delivery note needs to be passed onto the explosives supervisor.

42.2 On Site Security of Explosives

At the time of preparation of this guidance there are no quarries that have operational explosive stores on site. This guidance takes cognisance that this situation may alter and guidance relating to explosive stores is included for information purposes.

The arrangements and responsibilities for the storage and security of explosives on site must minimise the risk of loss or theft. Requirements regarding the security of explosives at a particular site may be set out in the stores explosive license if one is held. Advice regarding on site security of explosives should be sought from An Garda Síochána and the Department of Justice, Equality and Law Reform.

The explosives supervisor should authorise persons who may handle explosives at a quarry. The keys to any explosive store must be kept safe at all times, either in the custody of the explosives supervisor, shotfirer or explosives storekeeper, or in a secure place. To ensure the safety and security of the explosives there should be appropriate arrangements for authorising all movements of explosives to and from the place of use. The duties of the storekeeper in charge of the explosives store (where storage is licensed) include:

- ▶ the security and safe storage of explosives, including detonators;
- ▶ the custody of keys;
- ▶ record keeping;
- ▶ the issue and receipt of explosives; and
- ▶ reporting any loss or theft of explosives immediately to a designated person.

42.3 Use of Vehicles to Transport Explosives at the Quarry

Parts of vehicles where explosives are carried must be kept clean and free from grit. Detonators must be kept and transported in appropriate containers and enclosed in a strong, locked compartment when they are being carried on a vehicle. Explosives must be loaded safely so that they cannot fall out of or off the vehicle.

Anything that may create a fire or detonation risk must not be carried on a vehicle containing explosives, ammonium nitrate fuel oil mixtures or emulsion explosive matrix. Anything else which is carried, must be safely stored, normally in suitable separate compartments or containers. It is good practice to ensure that only essential shotfiring equipment (circuit - testers, stemming rods, shotfiring cable and tools for removing surplus explosives) is carried on such vehicles.

All vehicles transporting explosives (including detonators) in the quarry must be provided with suitable fire extinguishers. They must also be easily recognisable from a distance, for example, by means of signs, distinctive flashing lights or flags.

Trailers must have efficient brakes and a properly designed rigid tow bar with a safety chain, which will cause the brake to be applied in the event of separation.

42.4 Provision and Maintenance of Equipment

The equipment provided for shotfiring operations must be suitable and properly maintained. Inspection and maintenance arrangements must be set out in the quarry inspection scheme in Part 3, Section 16 of this guidance.

The explosives supervisor should also check that the equipment provided is suitable and safe. Any equipment the explosives supervisor does not believe is safe should be taken out of use.

Shotfiring equipment

Circuit-testers must be capable of measuring the resistance of the circuit without any adverse effect on the detonators. Exploders and circuit testers need detailed inspection, including appropriate testing, at periods specified by the manufacturer or every six months whichever is the shorter. Such inspection is also needed after any significant repair or unexplained misfire.

The inspections and tests should be designed to ensure that exploders and circuit testers are in good order and meet their designed performance ratings and that exploders can fire shots up to their rated capacities. A record of the results of any inspections and tests must be retained for a period of six years.

Tools used for piercing cartridges, mixing explosives or in shotholes (e.g. for charging, stemming, testing or

removing explosive) must be made of non-sparking materials such as wood, anti-static plastic or non-ferrous metal.

Electric detonators must not be used inside shotholes where there is a risk of premature detonation due to the build up of static charge. This is an issue when, for example, shotholes are lined with plastic sleeves or where rigid plastic containers are used, unless the lining is anti-static.

Explosives mixing trucks must be earthed during mixing and transfer operations to dissipate static charges. A device for removing excess emulsion/slurry should be provided.

Delay detonators should be clearly marked with the period of delay when supplied. This period should also be marked on the detonator lead.

42.5 Disposal of Surplus and/or Deteriorating Explosives

Serious incidents have occurred during the destruction of packaging due to the presence of explosive cartridges, detonating cord or detonators. Serious incidents have also occurred during the intentional destruction of surplus explosives and detonators when manufacturer's instructions and guidelines were not strictly adhered to.

There should be arrangements in place to check that no explosive material remains hidden or lodged within any packaging before the disposal of any packaging commences. The disposal of packaging, surplus and deteriorating explosive must be carried out in strict accordance with the manufacturers/ suppliers instructions and guidelines. These instructions and guidelines are required to be contained in the operator's shotfiring rules in the quarry safety statement.

43. SHOT FIRING RULES (Regulation 46)

46. *The operator shall ensure that suitable shotfiring rules are made and complied with. Such rules shall set out procedures for the following:*

- (a) *shotfiring operations at the quarry,*
- (b) *appointing explosives supervisors, shotfirers, trainee shotfirers and storekeepers,*
- (c) *authorising other persons who will be involved with the storage, transport, use or disposal of explosives,*
- (d) *dealing with misfires,*
- (e) *disposing of surplus explosives, detonators, accessories and packaging.*

The shotfiring rules are the practical operating procedures, which are in place to ensure that shotfiring operations take place at a quarry with regard to the safety of the workforce and the public.

The rules need to take account of local circumstances, such as any risk of accidental initiation due to static electricity, radio frequency transmitters, electrical powered plant and overhead power lines. If there is such a risk, a suitable method for initiation must be chosen. Shotfiring rules should be available at the quarry and copies given to those who have duties under them. The operator must ensure that arrangements are made to monitor compliance with the rules. The rules need to cover arrangements for:

- (a) the appointments and authorisation of explosive supervisors, shotfirers, trainee shotfirers, storekeepers (where storage is licensed) and others working with explosives;
- (b) the explosives supervisor to check that:
 - (i) the equipment provided is suitable and safe; and
 - (ii) site conditions are in line with the blast specification before working with explosives;
- (c) times when shotfiring is permitted;
- (d) the determination of the danger zone likely to be created by the firing of each shot, the evacuation and control of the danger zone and the provision of effective shelters when a shot is tested or fired;

- (e) warning systems including, as appropriate:
 - (i) the use of flags or notices;
 - (ii) a system of audible signals to warn people to withdraw from the danger zone and to give the all clear;
 - (iii) the posting of sentries;
- (f) inspection of the blast site after firing to check the state of the face and whether a misfire has occurred;
- (g) ensuring that normal working is resumed only when the shotfirer is fully satisfied that it is safe and the all clear is sounded;
- (h) safeguarding charged, but unfired shotholes at the end of the working day. These arrangements should ensure that someone is in attendance, or within sight of the charged holes at all times to prevent theft or unauthorised initiation of the explosives (including detonators);
- (i) dealing with misfires and the discovery of unfired explosives from previous operations. There must always be a competent person available, normally the explosives supervisor, to ensure that any misfire is dealt with safely;
- (j) safe disposal of surplus explosives (including detonators) that may remain after completion of shotfiring; and
- (k) monitoring arrangements to ensure the rules are complied with.

44. BLASTING SPECIFICATION (Regulations 47)

47. *The operator shall ensure that -*

- (a) *an adequate written blast specification, including identification of the danger zone based on an assessment of the risks, is prepared by the explosives supervisor for each shotfiring operation at the quarry to ensure that, so far as is reasonably practicable, when such shotfiring occurs, it will not give rise to danger, and*
- (b) *a copy of any relevant information contained in the blast specification referred to in paragraph (a) is given to any person upon whom it imposes duties*

The purpose of the blasting specification is to minimise the risk associated with the firing of shots. The blasting specification must be specific to each blast, to take account of site conditions. The specification should be designed to:

- ▶ minimise the risk of flyrock being projected outside of the declared danger zone;
- ▶ minimise the risk of misfires
- ▶ enable the location of any misfired shots to be accurately determined; and
- ▶ ensure, where possible, that faces are left in a safe condition after a blast.

The specification should take account of:

- (i) experience gained from previous blasts at the quarry;
- (ii) any unusual circumstances which are present or likely to arise; and
- (iii) the design of the excavation.

The following matters need to be addressed when planning, preparing for and undertaking a blast:

1. The location of the area to be blasted in the quarry must be specified;
2. A drilling plan should be prepared showing the hole positions, the length, diameter and the angle of inclination of each hole and direction to which the drill is to be set for each hole;
3. The surface position and number or other identifier for each shothole;
4. The angle of inclination, direction, length and diameter of, and extent of any sub grade drilling for each completed shothole;
5. The burden around each shothole should be adequately determined. Where this cannot be done safely from the top or base of the quarry face it must be determined by surveying/profiling or by other remote means by which a person is not placed at a risk of falling or being struck by falling objects from the face or the bench. Surveying/profiling of the working face to establish burdens is not mandatory. Its use is based on a risk assessment by the explosive supervisor/shotfirer in order to determine the likelihood of hazardous flyrock.

The risk assessment should take into account the following factors:

- ▶ control measures required to ensure the safety of persons determining the burden from either the top or bottom of the quarry face;
 - ▶ height of the face;
 - ▶ planned burdens and spacings;
 - ▶ diameter, angle and azimuth of the shotholes;
 - ▶ type and quantities of explosive used and the initiation systems;
 - ▶ geology of the face and the history of the quarry in relation to geological anomalies; and
 - ▶ proximity of the public, dwellings, roads, railway lines, commercial buildings or other places of work to the blast area.
6. Any geological anomalies, which could affect the blast, in particular those identified during drilling and inspection. These might include the presence of cavities, clay bands, joint planes, bedding planes or discontinuities;
 7. Using the available information, particularly that from items 4, 5 and 6, shown using plans and sections, the burden for each shothole should be determined and consequently the amount, type and placement of explosives to be used, so that the blast can be carried out safely;



Figure 36: Damage caused by Fly-rock.

8. The amount, type and position of explosives, the description and position of any detonator and the type and position of any stemming actually used for each shothole;
9. The system of initiation, including full details of any delay sequence and timing;
10. The danger zone, shotfiring position and sentry positions should be determined;
11. The date and time of the blast and prevailing weather conditions.

The blast specification should record information on all of these matters.

45. SHOTFIRING OPERATIONS (Regulation 48)

48. *The operator shall ensure that -*
- (a) *so far as is reasonably practicable, each shotfiring operation is carried out safely and in accordance with the shotfiring rules and blast specification,*
 - (b) *all shotfiring operations are carried out under the close personal supervision of the shotfirer,*
 - (c) *a trainee shotfirer at the quarry does not fire shots, except when -*
 - (i) *he or she is under the close personal supervision of a shotfirer, or*
 - (ii) *the operator is satisfied that he or she-*
 - (I) *has completed a suitable period of training,*
 - (II) *has appropriate practical experience, and*
 - (III) *is competent,*
 - (d) *records of all shotfiring operations carried out at the quarry are kept.*

Shotfirers must ensure that all shotfiring operations (as defined) are conducted in accordance with the shotfiring rules and the blast specifications.

Explosives mixed under licence on site must comply with the conditions set out on the licence. They must be mixed where they are to be used and only in sufficient quantities for immediate use.

The shotfirer must be fully satisfied that each shothole has been drilled and charged in accordance with the blast specification. Where pumped emulsion explosives are used the rise of the explosives in holes should be checked at regular intervals to ensure the

shothole is being correctly charged.

If it is not possible to conform to the specification, or the danger zone appears to be different from that shown, shotfiring operations should be suspended until any change to that specification has been authorised by its author or other designated person.

The shotfirer should only connect a tester to a shotfiring circuit when ready to test or fire the shot. The exploder should be disconnected immediately after firing or in the event of an unsatisfactory test on the firing circuit. Only the shotfirer or a trainee shotfirer under the close supervision of a shotfirer should be able to operate the exploder.

All persons must obey any relevant instructions in relation to shotfiring operations, for example, from the shotfirer or sentries. Sentries are there to prevent persons entering the danger zone and must not leave their post until the all clear signal has been given, or until released by the person who appointed them.

46. DUTIES OF EXPLOSIVES SUPERVISOR AND SHOTFIRER (Regulation 49)

- 49.
- (1) *The explosives supervisor at the quarry shall -*
 - (a) *advise the operator as to the observance of the relevant statutory provisions in relation to the storage, transport, use and disposal of explosives at the quarry,*
 - (b) *organise and supervise all work involving the storage, transport, use and disposal of explosives at the quarry,*
 - (c) *based on an assessment of the risks, prepare in writing a blast specification for each shotfiring operation which, so far as is reasonably practicable, shall ensure that, when shotfiring occurs, it will not give rise to danger,*
 - (d) *ensure that, prior to shotfiring operations being carried out, he or she is familiar with the area that may be affected by the shotfiring operations, inspects the face to be blasted and is satisfied that the blast specification is adequate,*
 - (e) *ensure that no person carries out any work in relation to explosives unless they are trained, adequately supervised and*

instructed to do so, and

- (f) *ensure that all equipment to be used in shotfiring operations is suitable, safe and adequately maintained.*
- (2) *The explosives supervisor and the shotfirer at a quarry shall carry out any shotfiring operations in accordance with the shotfiring rules and blast specification.*
- (3) *Before a shot is fired, a shotfirer shall -*
 - (a) *ensure that no person is within, or may enter within, the danger zone specified in the blast specification when the shot is being fired,*
 - (b) *check the shotfiring system or circuit to ensure that it has been connected correctly,*
 - (c) *where electrical detonators are used, ensure that they have been correctly connected to the shotfiring system or circuit and that the shotfiring system or circuit is tested with an instrument suitable for the purpose,*
 - (d) *where appropriate, ensure that the electrical integrity of the shotfiring system or circuit is such as to make a misfire unlikely, and*
 - (e) *ensure that a warning signal is given and that the shot is fired from a safe place.*
- (4) *After a shot is fired, a shotfirer shall -*
 - (a) *ensure that no person enters within the danger zone specified in the blast specification until the all-clear signal is given,*
 - (b) *inspect the blast site to check the result of the blast, the condition of the face and whether any misfire has occurred,*
 - (c) *report immediately any hazardous conditions or misfires to the operator and the explosives supervisor, and*
 - (d) *ensure that normal working is resumed only when he or she is satisfied that it is safe to do so.*

This regulation pulls together the requirements to ensure safety in relation to shotfiring operations and clearly states the duties assigned to the explosives supervisor and shotfirer involved. The explosives supervisor must ensure the overall safety of the shotfiring operation and advise the operator in relation to compliance with the regulations. The explosives supervisor must be familiar with the area to be blasted and must ensure that the blast specification

is appropriate during blast design and before the shot is fired.

The explosives supervisor must ensure that no unauthorised person carries out any work in relation to explosives and that the operating procedures, shotfiring rules and prepared blast specification are followed.

The shotfirer will be in charge of the physical loading of the blast and must ensure that all shotfiring operations are carried out in accordance with the shotfiring rules and prepared blast specification for each blast. Any deviation or alteration of the blast specification during the loading of the blast must be approved by the explosives supervisor before the shot is fired. The physical integrity of the blast is the responsibility of the shotfirer. Connections must be checked immediately before a blast to ensure the integrity of the system and to minimise the risk of a misfire. Where in-hole initiation is used, i.e. with the detonator placed inside the hole, two detonators are recommended for each deck or column of explosives to minimise the possibility of a misfire occurring. This is because faulty detonators cannot be easily identified or recovered.

Before a shot is fired, a shotfirer must –

- (a) check the shotfiring system or circuit to ensure that it has been connected correctly;
- (b) where electrical detonators are used, ensure that they have been correctly connected to the shotfiring system or circuit and that the shotfiring system or circuit is tested with an instrument suitable for the purpose;

Figure 37: Drilled Face



- (c) where appropriate, ensure that the electrical integrity of the shotfiring system or circuit is such as to make a misfire unlikely;
- (d) ensure that an adequate danger zone is established, cleared and sentries appointed to prevent inadvertent access; and
- (e) ensure that the shot is fired from a safe place.

The danger zone should be as large as reasonably possible and should ensure that materials from the blast are not projected beyond it.

After the shot is fired, the shotfirer must –

- ▶ ensure nobody enters the danger zone until the all clear signal is given,
- ▶ inspect the blast to ensure that all holes have fired and that no misfires have occurred,
- ▶ ensure that the quarry face and sides are in a safe condition
- ▶ establish that material did not project beyond the danger zone

If during the course of an inspection of the blasted area, or at some later date, it is discovered that materials were projected beyond the defined danger zone for that blast and that persons, either employed at the quarry or other persons who may be affected, were placed at risk of injury then the details must be recorded on the blasting records. As soon as is reasonably practicable the explosives supervisor must investigate the cause of such projection of fly rock and ensure that all measures are taken to prevent re-occurrence at subsequent blasts.

47. MISFIRES (Regulation 50)

50. In the event of a misfire, the operator, in consultation with the quarry manager (if not the same person), shall ensure, so far as is reasonably practicable, that -

- (a) no person, other than himself or herself, the explosives supervisor, the shotfirer, any trainee shotfirer or any other person authorised by him or her, enters the danger area -
 - (i) where the shot was fired by means of safety fuse, until a period of 30 minutes has elapsed since the misfire, or

- (ii) where the shot was fired by other means, until a period of 5 minutes has elapsed since the misfire and any shotfiring apparatus has been disconnected from the shot,
- (b) appropriate steps are taken to determine the cause of the misfire and to deal with it, and
- (c) a suitable record is kept of the misfire and any action taken.

All misfires must be investigated to determine the cause and to enable action to be taken to avoid a recurrence. A record should be kept of all misfires; the blasting specification endorsed with details of any misfire would be a suitable record.

Any misfire resulting in injury requiring medical treatment to persons within or outside the quarry boundaries either workers, contractors or members of the public should be reported to the Authority on Form IR1 "Reporting of Accident" as required by the Safety, Health and Welfare at Work (General Application) Regulations.

48. PROHIBITED ACTIVITIES (Regulation 51)

51.

- (1) No person, other than -
 - (a) a person engaged in the transport of explosives or detonators to or from a quarry,
 - (b) an explosives supervisor,
 - (c) a shotfirer or trainee shotfirer,
 - (d) a storekeeper, or
 - (e) any other person authorised by the operator to do so shall handle explosives or detonators at a quarry.
- (2) No person shall bring any substance or article (other than explosives) likely to cause an unintended explosion or fire within 100 metres of any explosives or (except for the purpose of lighting igniter cord or safety fuse) take any naked flame within 100 metres of any explosives at a quarry.
- (3) No person shall forcibly remove any detonator lead, safety fuse or other system for initiating shots from a shothole at a quarry after the shothole has been charged and primed.

- (4) *No person shall charge or fire a shot -*
- (a) *unless there is sufficient visibility to ensure that work preparatory to shotfiring, the shotfiring operation and any site inspection after the shot is fired can be carried out safely, or*
 - (b) *in a shothole in which a shot has previously been fired, unless he or she is dealing with a misfire in accordance with action taken under Regulation 50(b).*
- (5) *No person shall fire a shot at a quarry -*
- (a) *unless he or she is an explosives supervisor, shotfirer or trainee shotfirer within the meaning of these Regulations, or*
 - (b) *other than by means of a suitable exploder or suitable safety fuse.*
- (6) *No person shall cap a safety fuse with a detonator unless he or she is using equipment designed for the purpose and he or she is in a suitably sheltered place designated by the operator for the purpose.*
- (7) *No person, other than an explosives supervisor, a shotfirer or trainee shotfirer, shall dispose of surplus explosives, detonators, accessories or packaging remaining following shotfiring operations at a quarry.*

No unauthorised person can handle explosives or detonators or be involved in any way in the shotfiring operations. The shotfirer must be present during all charging and firing operations.

Detonators, other explosives and charged holes must not be left unattended. All detonators must be locked in their containers when not in use. Any surplus explosive (including detonators) must be removed from the blast area before any attempt is made to fire the shot. The shotfirer must ensure that surplus explosives are not left unattended. Surplus explosives should be returned to the explosives store or returned to the manufacturer/supplier. Where this is not possible the explosives should be destroyed by the shotfirer in accordance with the manufacturer's/supplier's instructions and guidance.

Safety fuse needs to be of such quality that the rate of burning is between 90 and 110 seconds for each metre of fuse. It is recommended that a shotfirer should not attempt to ignite more than six lighting points at any

one time. When igniter cord is being used to connect lengths of safety fuse, the initiation system should be such that the last length of safety fuse has started to burn before the first detonation occurs.

Explosives or detonators should not be carried in the pockets or in clothing.

Explosives and detonators should remain in their containers until they are required for immediate use.

Explosives are not used on or inside machinery or used for clearing blockages except where all other means have failed and the explosives are used in accordance with the manufacturer's/supplier's guidance.

Explosives and detonators should not be taken into a room or other place where people congregate, or where there is a possible source of ignition, for example, from machinery, electrical equipment or a naked flame.

Blasting Times

A blast should not be carried out if there is insufficient visibility to carry it out safely. Any local authority conditions or advice on the timing of blasts should be complied with. Where there are private houses, schools, businesses etc situated close to the quarry it is good practice to notify the occupants of blasting times.

49. INTRODUCTION TO THIS PART

Persons in or near a quarry should not be at risk due to the collapse of a quarry face or from the movement of all or part of an excavation, tip or lagoon. The appraisals and assessments, which are explained in the following Sections, are tools to ensure that this general objective is achieved. The flowchart in figure 43 explains the relationship between the appraisal and assessment requirements.

Excavations

The term ‘excavation’ for the purpose of this guidance, includes any place at a quarry where minerals are or have been extracted. In particular, it includes the floor, benches, faces and sides of a quarry and any other incline, for example, access ramps and other cuttings which are made for the extraction of minerals.

Tips

All tips, including stockpiles are covered in this Section. Tips will include, accumulations or deposits of materials used in connection with the quarry, spoil heaps and all material stored in the quarry for refilling the excavation or landscaping the site after excavation, stockpiles of materials for later processing or sale, amenity and soil bunds.

Lagoons

Lagoon means any natural or artificial pond or other water filled excavations at a quarry to treat the water at the quarry where sunlight, bacterial action and oxygen work to purify waste water and also include the storage or ponding of other wastewaters, sludges and liquid wastes.

“**geotechnical specialist**” means a professional engineer or professional geologist who -

- (a) has 3 or more years relevant experience in soil mechanics, rock mechanics or excavation engineering,
- (b) is competent to perform a geotechnical analysis to determine the hazard and risk arising from the excavation or tip being assessed, and
- (c) has attained a position of professional responsibility and is accredited by a relevant professional organisation;

“**hazard**” in relation to an excavation, tip or lagoon means having the potential to cause harm to the safety, health or welfare of any person;

50. GENERAL DUTY TO ENSURE SAFETY OF EXCAVATIONS, TIPS AND LAGOONS (Regulation 52)

52. *The operator shall ensure that excavations (including quarry faces), tips and lagoons are designed, constructed (in relation to tips and lagoons), operated and maintained so as to ensure, so far as is reasonably practicable, that instability or movement which is likely to give rise to a risk to the safety, health and welfare of any person is avoided.*

All excavations, tips and lagoons must be designed, constructed and maintained to ensure their safety. The measures taken to reduce the risk should be proportionate to the hazard posed. In the case of a very small face, tip, or lagoon this will usually be minimal. While a full geotechnical assessment will only be required on certain excavations, tips or lagoons the operator must ensure that they are all properly designed and constructed.

The design and operating procedures for excavations, tips and lagoons must aim to minimise the risk to persons at the quarry and those who may be affected by its activities. This includes persons at the quarry who need access to potentially hazardous areas for the purposes of carrying out inspections and assessments. Key operating instructions and safe procedures must be set out in the excavations, tips and lagoons operating procedures.

The inspection scheme should include the data obtained from the design, normal operations, inspection, appraisal and assessment work.

Any excavation, tip or lagoon, which move are potentially unsafe. Appropriate procedures should be implemented immediately to determine the risk and required remedial action. This will involve reappraisal or reassessment as soon as possible.

50.1 Design of Excavations, Tips and Lagoons

When a new tip, excavation or lagoon is to be created it is necessary to carry out planning and design to ensure it can be developed without becoming a significant hazard both during its construction and during its subsequent use. To ensure that all hazards have been evaluated it will be necessary to carry out a site investigation.

A site investigation should include any relevant historical information about the site and its surroundings and should be carried out before starting a new excavation, tip or lagoon. The purpose of this is to ensure a design which is safe and enables safe operation. See Schedule 3 of the Regulations at Appendix 3.

If all relevant data is not available or is not reasonably accessible additional investigations may be required or extra caution may be required to be built into the design, particularly if the information is critical. The design should conform to good engineering practice and relevant standards. Slopes should be so designed to provide stability throughout their life. The risk of failure of the excavation, tip or lagoon should be assessed to ensure the design provides an adequate margin of safety.

The excavation, tip or lagoon may need to be re-assessed and redesigned as a result of information obtained during routine working, inspection, appraisal or geotechnical assessment. Simple management procedures are, therefore, needed to ensure that any such information relevant to the design is reviewed.

Where an appraisal of an existing excavation, tip or lagoon indicates that there could be a concern that may constitute a significant hazard at a later date it may be necessary to carry out a site investigation if such information is not already available in order to ascertain if a geotechnical assessment is required.

Where a proposed excavation, tip or lagoon is likely to constitute a significant hazard and will require a geotechnical assessment it is strongly recommended that a geotechnical specialist is involved in the design stage. In such cases, the original design, appraisal and assessment may be amalgamated and the design documentation may form the assessment report provided it addresses all the relevant matters covered by Schedule 3 of the Regulations.

The maximum safe height of excavated faces is influenced by the geology and physical properties of the material, the size, height and type of machinery and working methods used. However, where the face height exceeds 20 metres a geotechnical assessment is required. Generally, the lower the face, the easier it is to safely manage and maintain it. In operations involving unconsolidated materials the height of the face should be based on risk assessment which includes the physical properties of the materials worked, particularly its natural angle of repose and the

extraction methods used and face heights above 7.5 metres should generally be avoided.

Higher faces can be difficult to manage and do not generally optimise production, caution should be taken as:

- ▶ there is an increased tendency to produce toes or overhangs and back break is common
- ▶ maintaining the azimuth and inclination of drill holes is more complex as there is a greater tendency for drill wander and this increase the potential for a misfire resulting from intersecting drill holes or unidentified reduction in the burden and/or spacing.
- ▶ a larger column of explosives increases the maximum instantaneous charge resulting in vibration issues which may require decking of the holes.
- ▶ scaling and removing loose blocks, where necessary, at the top of the quarry is difficult and more dangerous as standard excavators only have limited reach even when operating on a rock pad as the need for a rock trap also limits the reach and it is also difficult to carry this operation from the top of the quarry face using an excavator as the dipper arm prevents the bucket from crowding back.

Figure 38: Horizontally bedded strata



Figure 39: Steeply dipping strata



50.2 Working Excavations, Tips, and Lagoons

Excavations, tips and lagoons should be developed in accordance with the design. Procedures should be in place to ensure proper control of any design changes. These may be included in the safety statement or in the excavations, tips and lagoons procedures. Working methods should avoid creating vertical faces or overhangs which constitute a risk of collapse. Re-profiling or digging material from a tip also needs particular attention as it can lead to instability.

Extra care is required when extracting material below water due to the risk of collapse. Areas liable to be affected are hazardous and should be treated appropriately.

Additional precautions may be required to prevent risks arising where tipping and removal from a stockpile take place simultaneously. For example, a tipping area must not be undermined by removal of material.

Stockpiles

It is important to remember that the legal term 'tip' includes stockpiles. These can be as hazardous as other tips, and so they too need to be properly designed and operated. The excavations, tips and lagoons safe operating procedures are the key to this. Frequent geotechnical assessment may be necessary for very large potentially hazardous stockpiles.

Walls or other supports provided to contain stockpiles should be designed by a competent person and considered as part of the stockpile during appraisal or assessment. Stockpiles which are not free draining should be provided with additional drainage.

Market conditions may affect the size of a stockpile. If this happens the stability of the stockpile should be reassessed.

Adjacent stockpiles can have an effect on each other, particularly where they overlap. The adequacy of traffic routes for vehicles should also be considered when planning the position and size of stockpiles. In particular, the risk of collision can be minimised by ensuring a clear view for drivers.

51. OPERATING PROCEDURES FOR EXCAVATION, TIPS AND LAGOONS (Regulation 53)

53. *The operator shall ensure that suitable operating procedures are in place for the safe operation of excavations, tips and lagoons and that such procedures, in particular, specify -*

- (a) *the manner in which such activities are to be carried out,*
- (b) *the nature and extent of supervision of such activities, and*
- (c) *the protective measures to be taken during such activities to ensure the safety, health and welfare of any person and the safety and stability of the excavation, tip or lagoon.*

These procedures are essential for the proper management of excavations, tips and lagoons. They are the practical measures to ensure the safety of persons in the vicinity. They should offer straightforward practical guidance.

The frequency of inspection of excavations, tips and lagoons is covered by the inspection scheme required under Section 16 of this guidance. These inspection arrangements may be incorporated into the operating procedures.

If a geotechnical specialist has been involved in the design, or has carried out a geotechnical assessment, their recommendations should be taken on board when preparing safe operating procedures.

Operating procedures should specify the manner in which the excavation, tip or lagoon will be constructed and managed to ensure safety. They need to address, where relevant:

- (a) the maximum depth/height;
- (b) the preparation necessary (for example the standard of foundations required for a tip);
- (c) the provision of drainage (particularly under, in and on tips) and how it is installed, maintained and inspected;
- (d) the height and slope of faces and the thickness of the layers in which a tip is constructed;
- (e) the type of plant and machinery used;
- (f) the construction standards for roadways and arrangements to prevent tipping vehicles driving or reversing over edges, including the

- size and shape of edge protection;
- (g) the supervision needed to ensure that work is carried out in accordance with the design;
- (h) what to do if particular defects are found. (This should take into account the extent of the defect, the working methods, the nature of the material and the proximity and vulnerability of neighbouring structures and personnel.); and
- (i) the way material may be removed from the excavation, tip or lagoon, if relevant, including the maximum vertical working face height which may be created or left at the end of the working period.

The operating procedures for excavations should also address:

- ▶ The sequence in which the site will be excavated;
- ▶ The frequency of inspection, appraisal and assessment,
- ▶ The maintenance arrangements for faces, for example mechanical scaling.

The operating procedures for tips should also address, in the case of solid tips, the degree of compaction required for tipped material.

The operating procedures for lagoons should also address, as relevant:

- (a) the provision of emergency overflows;
- (b) minimum freeboard heights;
- (c) the operation or maintenance of pumps;
- (d) procedures to allow materials to be recovered safely from lagoons; and
- (e) procedures when covering lagoons.

52. APPRAISAL AND SITE INVESTIGATION OF EXCAVATIONS, TIPS AND LAGOONS (Regulation 54)

54.

- (1) Subject to paragraph (2), the operator shall ensure that, before quarrying operations commence or re-commence in a particular area in the quarry, a suitable appraisal of all proposed and existing -
- (a) excavations,
 - (b) tips, and

(c) lagoons

in that particular area is undertaken by a competent person in order to determine whether any such excavation, tip or lagoon represents a significant hazard, or a potential significant hazard.

- (2) *Where the face height of an excavation in a particular area of the quarry planned to be worked exceeds 20 metres, the operator shall ensure that, before quarrying operations commence or re-commence in that particular area, a geotechnical assessment is carried out in accordance with Regulation 55.*
- (3) *Where an appraisal by a competent person under paragraph (1) identifies a significant hazard that cannot be rectified immediately in a safe manner, the operator shall ensure that the provisions of subparagraphs (a) to (c) of paragraph (5) are complied with.*
- (4) *Where an appraisal by a competent person under paragraph (1) identifies a potential significant hazard that cannot be rectified immediately in a safe manner, the operator shall ensure that -*
 - (a) *the provisions of subparagraphs (a) and (b) of paragraph (5) are complied with, and*
 - (b) *a geotechnical specialist carries out a site investigation to determine whether a geotechnical assessment under Regulation 55 is required.*
- (5) *Where the conclusion reached by the geotechnical specialist, following a site investigation made under this Regulation, is that the excavation, tip or lagoon represents a significant hazard, the operator shall ensure that -*
 - (a) *appropriate protective measures are taken, including informing all persons affected by it,*
 - (b) *only work that can be carried out safely is undertaken at the excavation, tip or lagoon, and*
 - (c) *a geotechnical assessment is carried out in accordance with Regulation 55.*
- (6) *The operator shall ensure that -*
 - (a) *any significant findings, and*
 - (b) *any conclusions reached and the reasons for those conclusions made under an appraisal or a site investigation pursuant to*

this Regulation are recorded by the competent person or the geotechnical specialist, as the case may be.

An appraisal is intended to be a straightforward exercise to determine which excavations tips and lagoons, proposed or existing, would pose a significant risk if they failed, or in the case of a tip or lagoon, move significantly more than that allowed in the design, and so merit an assessment by a geotechnical specialist. The relationship between the appraisal and assessment are illustrated in the flow chart in figure 43.

Some appraisals will only identify those hazards from isolated minor failures, such as falls of a single rock or a small amount of sand. A geotechnical assessment does not focus on such hazards. While isolated falls of ground can be serious, they can generally be rectified immediately and be adequately controlled by routine daily inspection, use of appropriate equipment and working methods.

The appraisal should be carried out with enough detail and sufficient expertise to decide, on the basis of the guidance in this Section, if an excavation, tip or lagoon poses a significant risk from collapse or movement. It is not normally necessary for appraisals to be carried out by a geotechnical specialist, though advice from one is appropriate where the level of hazard is unclear.

When carrying out an appraisal there is no need to duplicate work already done, as long as all the matters detailed in this Section are adequately addressed. In some cases it is obvious that any failure of an excavation, tip or lagoon could prove fatal, for example, an excavation, or tip or lagoon near a public roadway, house or above quarry offices. In these cases the initial appraisal can be very brief as a geotechnical assessment by a geotechnical specialist will be needed.

Areas where no one is at risk from a collapse of part of an excavation must be included in the appraisal because failure in such areas could affect the stability of the remainder of the excavations. Appraisal of such areas may also provide information relevant to the safety of other parts of the excavation.

Among other things, the appraisal should take account of the material to be excavated or tipped, its structure, water content/drainage, the proximity of watercourses, roadways, workplaces, residential

accommodation or abandoned workings, and any evidence or historical failures. The matters covered in inspections are also relevant.

Significant hazard

To determine if the hazard is significant or potentially significant it is necessary to consider how an excavation, tip or lagoon might feasibly fail and the likely consequences of any such failure. The likely consequences are crucial when deciding if a particular hazard is significant. The probability of such a failure actually happening is not relevant in this context. The consequences depend on the likely scale of the failure and the area that could be affected by it, and whether people are likely to be injured.

The Health and Safety Authority have produced an information sheet entitled **Identifying Significant Hazards in Quarries** which is available electronically on the Health and Safety Authority website and is copied in Appendix 5 of this document.

The hazard should be considered significant or potentially significant if such a failure would directly or indirectly, be:

- ▶ liable to endanger premises, roadways or other places where people are likely to be found off-site; or
- ▶ likely to cause serious or fatal injuries to persons on or off-site.

If the degree of hazard is not clear and the excavation, tip or lagoon is not in the categories described in the "Excavations" or "Tips/Lagoons" Sections overleaf, the advice of a geotechnical specialist should be sought.

Where a geotechnical specialist has been involved in design work or in geotechnical assessments he or she may provide written, practical guidance on what constitutes a significant hazard or potential significant hazard in the context of that particular site. Any such guidance should explain the basis on which it was produced.

Such site-specific guidance may be followed for future appraisals, subject to limitations specified, in preference to the generic guidance in the Tips and Excavations Sections. Any such guidance should be made available to those carrying out appraisals and needs to be reviewed in the light of changes or new information.

Figure 40: Flowchart of the appraisal & assessments of excavations, tips and lagoons

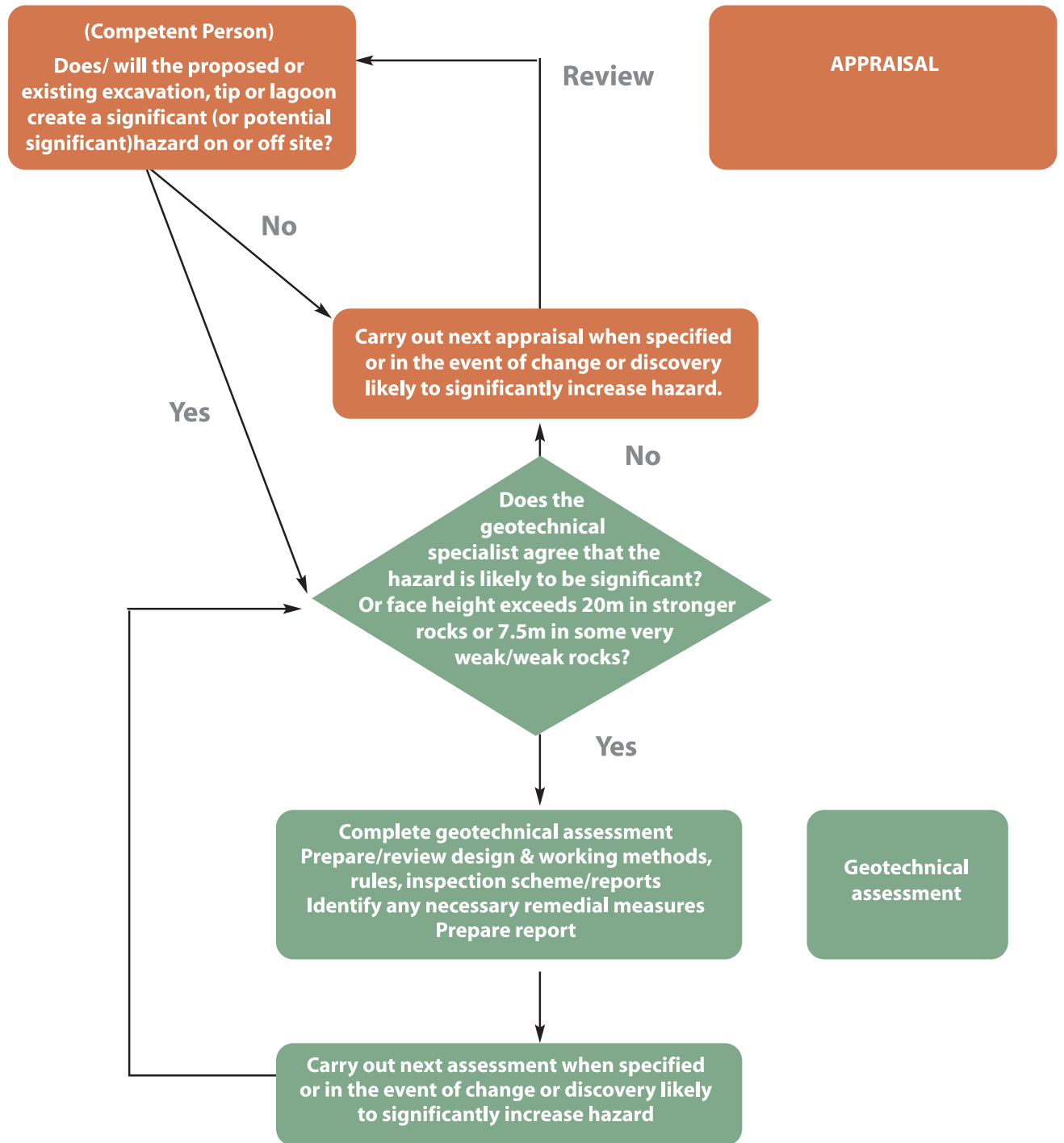

Figure 41: Significant Hazard – loose blocks above working area



Figure 42: Significant Hazard – unstable stockpile recovery face



Properly validated analytical techniques for calculating the hazard created by excavations, tips and lagoons may also be used to determine the significance of the hazard. Such techniques can also be useful in prioritising work.

Where an appraisal of any excavation, tip or lagoon identifies a potential significant hazard that can not be rectified immediately, the operator must engage a geotechnical specialist to carry out a site investigation to establish if a full geotechnical assessment is required.

Even where a significant hazard or potential significant hazard can be rectified immediately by the operator, it may still be necessary to have a site investigation and/or a geotechnical assessment carried out to identify what caused the development of the hazardous condition, what if any effects it had or may have on the

overall stability of the excavation, tip or lagoon and what actions are needed to prevent reoccurrences.

Excavations

Where the appraisal of the excavation carried out by a competent person identifies a significant hazard that can not be rectified immediately a geotechnical assessment will be required. The following list gives examples of where this may be necessary:

- (a) in the case of moderately weak or stronger rock which is normally excavated using explosives or saws -
 - (i) the vertical height of any individual face is more than 20 metres, or
 - (ii) where multiple benches are present and bench widths or the overall face angle may be inadequate to ensure quarry stability; or
 - (iii) where multiple benches are present and the overall depth of the excavation is in excess of 30 metres'
 - (iv) where there is a tip, lagoon, infrastructure or private lands within 30 metres of the top of the quarry face
- b) In the case of weak or very weak rocks and engineering soils, (for example clay or sand and gravel deposits or deposits not normally excavated using explosives/saws),
 - i) where the vertical height of any excavation exceeds 7.5 metres and,
 - ii) the overall face angle is steeper than a suitable angle to ensure safety (see figure 44); or
- c) Irrespective of any excavation face height, depth or angle, other factors, for example, the geology, changes in hydrology or groundwater, location or proximity of a tip, location or proximity of infrastructure or private lands means that there is a significant hazard as described in that Section of this guidance.

Tips/Lagoons

Where the appraisal of the tip/lagoon carried out by a competent person identifies a significant hazard which can not be rectified immediately a geotechnical assessment will be required. The following list gives examples of where this may be necessary:

- (a) in a wholly, or mainly, solid state and not in solution or suspension (i.e. not likely to flow if not contained); and -

- (i) the area of the land covered exceeds 10,000 square metres, or
- (ii) the height of the tip exceeds 20 metres, or
- (iii) the average gradient of the land covered by the tip exceeds 1 in 12; or
- (b) a lagoon containing any liquid or material wholly, or mainly, in solution or suspension (likely to flow if not contained); and -
 - (i) the contents of any lagoon are more than 4 metres above the level of the land which is within 50 metres of its perimeter, or
 - (ii) the contents of the lagoon exceed 10,000 cubic metres, or
 - (c) irrespective of the size of the tip/lagoon, the side-slopes or slopes of the containment bund or other factors, for example, the geology, changes in hydrology or groundwater, location or proximity to an excavation, mean that there is a significant hazard or potential significant hazard as previously detailed.

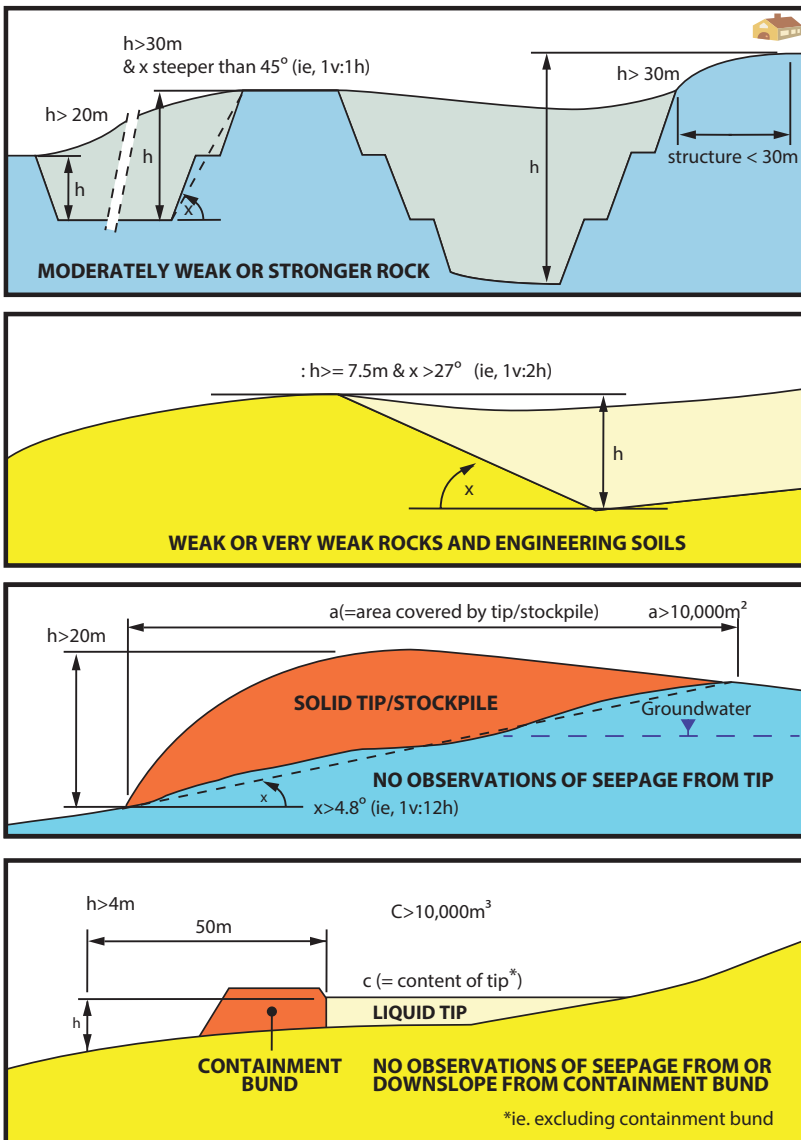

Figure 43: Criteria for significant hazards.

Material	Slope Geometry	Gradient	Angle
Moderately weak rocks or stronger rocks	1v:1h	100%	45°
Some Weak /very weak rocks or engineering soils	1v:2h	50%	27°
Tip base	1v:12h	8.3%	4.8°

Recording and reviewing the appraisal

Records of the conclusions of appraisals are required to be kept available at the quarry. The conclusions of the appraisal should be included in the safety statement. Where the excavation, tip or lagoon is considered to be unsafe, or likely to become unsafe in the near future, there should be a clear recommendation as to what action should be taken and when. Little needs to be recorded in other cases where the appraisal is to be followed by a geotechnical assessment. Where there is no significant hazard, the detail should be sufficient to explain the conclusions and how they were reached.

The appraisal should be reviewed at appropriate intervals and in particular in light of:

- ▶ significant changes to working methods;
- ▶ experience of the geology and hydrology on site;
- ▶ changes outside the site which significantly increase the hazard, for example, the construction of houses or roadways near the boundary;
- ▶ evidence of significant failure or movement; or
- ▶ discovery of incorrect assumptions or errors in the appraisal.

Figure 44: Illustration of the terms 'overall face angle', 'individual face', 'toe' and 'crest'.

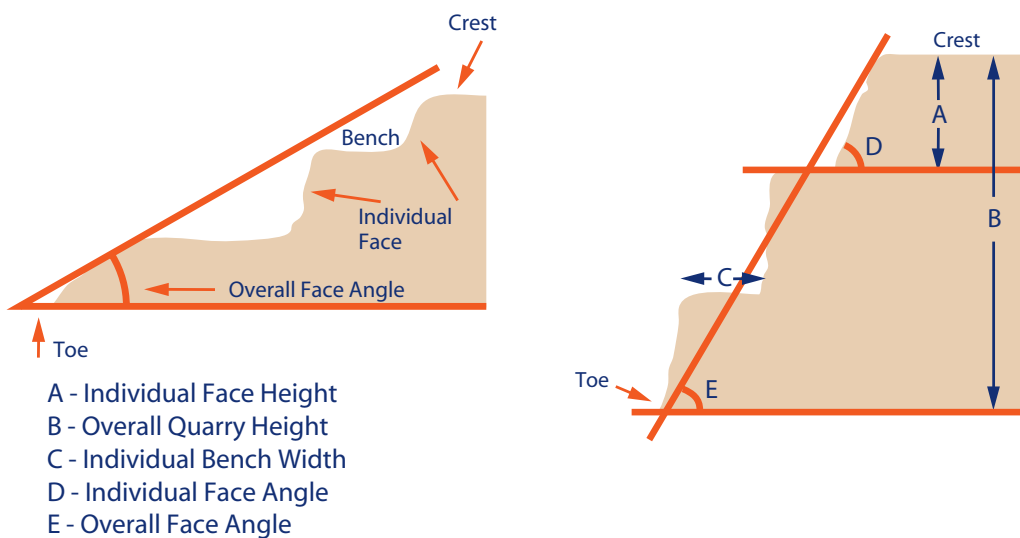

53. GEOTECHNICAL ASSESSMENT (Regulation 55)

55.

- (1) In this Part "geotechnical assessment" means an assessment carried out by a geotechnical specialist identifying and assessing all factors liable to affect the stability and safety of a proposed or existing excavation, tip or lagoon and shall include -
- (a) preparation by or under the supervision of the geotechnical specialist or, as appropriate, consideration by the geotechnical specialist of the documents and particulars specified in Schedule 3,
 - (b) the conclusions of the geotechnical specialist as to -
 - (i) the safety and stability of the existing or proposed excavation, tip or lagoon being assessed, including his or her conclusions as to whether the excavation, tip or lagoon represents a significant hazard by way of instability or movement,
 - (ii) whether any remedial works are required in relation to the excavation, tip or lagoon being assessed and the date by which such works should be completed,
 - (iii) the date by which the next geotechnical assessment should take place, and

(iv) where appropriate, any required changes to the operating procedures in respect of the excavation, tip or lagoon.

(2) The operator shall ensure that -

- (a) any significant findings made during a geotechnical assessment required under Regulation 54, any conclusions reached in accordance with paragraph (1)(b), and the reasons for those conclusions are recorded by the geotechnical specialist undertaking the assessment,
- (b) the geotechnical specialist signs and dates any such record and records his or her professional qualifications thereon,
- (c) (i) any information available that may be relevant for the purposes of a geotechnical assessment is made available to the geotechnical specialist undertaking that assessment, and
(ii) sufficient records are kept of the nature, quantity and location of all substances accumulated or deposited at a tip, excavation or lagoon to enable an accurate assessment of the stability of that tip, excavation or lagoon to be made,
- (d) any remedial works identified during the geotechnical assessment in accordance with paragraph (1)(b)(ii) are undertaken by the date specified or before quarrying operations are resumed,
- (e) where the conclusion reached by a geotechnical specialist in accordance with paragraph (1)(b) is that there is no significant hazard-
(i) the geotechnical specialist specifies the frequency with which appraisals under Regulation 54 are to be conducted in the future in order to ensure the continued safety and stability of the excavation, tip or lagoon, and
(ii) a record of that specification is made by the geotechnical specialist, and
- (f) copies of all geotechnical assessments are kept at the quarry for inspection and are retained by the operator for at least 10 years from the date they were made.

A geotechnical assessment means an assessment carried out by a geotechnical specialist identifying and assessing all factors liable to affect the stability and safety of a proposed or existing excavation, tip or lagoon. A geotechnical assessment may be preceded by a site survey and site investigation to establish critical information to assist in any full geotechnical assessment which may include:

1. Site survey

An accurate plan prepared on a scale not less than 1:2500 showing:

- (i) the boundaries of any quarry or premises upon which the excavation, tip or lagoon or proposed excavation, tip or lagoon is to be situated;
- (ii) the site of any excavation, tip or lagoon or proposed excavation, tip or lagoon;
- (iii) any adjoining land or structures which might be affected by the excavation, tip or lagoon or proposed excavation, tip or lagoon; and
- (iv) all mine workings (whether abandoned or not), buried quarry workings, known cave systems, active or former landslips, springs, artesian wells, watercourses and other natural or man-made features (including tunnels, pipes or culverts which might affect the safety of the excavation, tip or lagoon which might be relevant for the purpose of determining whether excavations or tipping operations can be carried out safely).

The plan should be contoured to an ordnance datum at a vertical interval not greater than 5 metres and orientated to and correlated with the ordnance survey national grid and marked with squares corresponding to the 100 metres squares shown in ordnance survey sheets on the scale of 1:2500.

2. Site investigation

A record of all relevant site investigation information including surveys, tests, bore-holes and groundwater measurements made for the purpose of the geotechnical assessment together with the results of any testing including the strength of materials within and beneath the tip, lagoon or within the excavated slope. The record must include any known historical information relevant to the site investigation.

3. Cross-sections based on site investigation

Sufficient accurate cross-sections on a scale not less detailed than 1:1250 of the site of the excavation, tip or

lagoon or proposed excavation, tip or lagoon showing the existing ground surface and all relevant superficial materials and bedrock underlying the said site and:

- (a) any variation in the thickness, level or character of the superficial deposits and bedrock materials based on the site investigation; and
- (b) the position of any surface, whether natural or manmade, which may affect the safety of the excavation, tip or lagoon or proposed excavation, tip or lagoon.

4. Plans based on site investigation

Plans showing the position of all bore-holes, wells and trial pits used in the site investigation and the location and levels of all materials and surfaces which may affect the safety of an existing or proposed excavation, tip or lagoon.

5. Assumptions made before analysis

A record of any assumptions relevant to the assessment of ground conditions relating to the safety of the excavation, tip or lagoon or proposed excavation, tip or lagoon made by the geotechnical specialist, including a record of any relevant information which was not available when undertaking the assessment.

6. Findings of the analysis

A record of the calculations carried out in order to determine the design or safety of the excavation, tip or lagoon, including any variables or parameters used in those calculations and the reasons for using them and the findings of those calculations expressed as the factor of safety or the probability of failure or other recognised basis of assessing stability.

7. Design coming out of the analysis

An accurate plan on a scale not less detailed than 1:2500 recording:

- (a) in relation to tips/lagoons or proposed tips/lagoons, the design of the tip/lagoons, including the areas of land covered or to be covered, the gradients of that land, the designed contours at vertical intervals not more than 2 metres, the side slopes and boundaries of the tip and the designed position and nature of any construction of any wall or any other structure retaining or confining the tip; and
- (b) in relation to excavations or proposed excavations, the design of the excavations, including the height or proposed height of

the slope, the position and width of any benches and representative contours of the excavation at vertical intervals of not more than 5 metres.

8. Requirements during and after construction

A record of the nature and extent of inspection, supervision and safety measures necessary to ensure the safety of the excavation, tip or lagoon and a specification of necessary engineering works and safety measures. A record of the action to be taken regarding defects specified in the report.

The operator must ensure that any information available to him or her, which may be relevant for the purposes of a geotechnical assessment, is made available to the geotechnical specialist undertaking that assessment.

The operator must ensure that any remedial works identified during the geotechnical assessment are undertaken by the date specified.

The geotechnical assessment should also cover similar topics to the appraisal but in greater depth and more detail.

It is important to ensure that the design, normal operation, inspection, appraisal, site investigation and assessment work are not carried out in isolation from each other. Information gained as a result of all these activities needs to be shared.

The report needs to be presented in a form that will help the operator to manage the safe development and continued operation of the excavation, tip or lagoon and to organise appropriate inspections.

Operators need to ensure that geotechnical specialists who conclude that an excavation tip or lagoon is not a significant hazard clearly explain the basis for their judgement. Where a tip and/or lagoon is near the crest of an excavation, the tip and/or lagoon and the excavation must be considered together.

Geotechnical specialist

The level of expertise required to carry out a geotechnical assessment depends on the complexity of the site and properties of the materials being worked, tipped or stored. The geotechnical specialist must have sufficient expertise and practical experience of similar conditions to adequately assess the safety of the excavation, tip or lagoon and the precautions required to make and keep it safe.

The operator must ensure that any remedial work identified during a geotechnical assessment is carried out by the date specified by the geotechnical specialist. When deciding how long to allow for remedial measures, the geotechnical specialist should consider the risk involved. The greater the risk, the sooner the work needs to be completed.

53.1 Operator's duties in relation to Excavations, Tips and Lagoon which are a Significant Hazard.

Excavations tips and lagoons that constitute a significant hazard must be subject to further geotechnical assessment at least once every two years. The date by which the next geotechnical assessment is to be carried out must be specified in the geotechnical specialist's report.

Some excavations, tips and lagoons will require more frequent geotechnical assessment. This may include spoilheaps and backfill where large quantities of material are deposited and/or excavated at a high rate.

Review

Further geotechnical assessments must be carried out at least every 2 years or as specified by the geotechnical specialist or in the event of:

- (a) significant changes to the working methods;
- (b) new information about the geology or hydrology of the site;
- (c) changes outside the site which significantly increase the hazard, for example, the construction of houses or roadways near the boundary;
- (d) evidence of significant failure or movement; or
- (e) discovery of incorrect assumptions or errors in the site investigation and/or assessment.

Wherever possible such assessments should be undertaken before any significant change, but where this is not possible they must take place as soon as reasonably practicable.

A change to the excavation or the tip itself, for example, in design, method of working, material tipped, may significantly increase the hazard. In each case a further geotechnical assessment must be carried out. This may also be required if fundamental assumptions in the geotechnical assessment are found to be incorrect, for example, regarding the geology of the site.

A new development on land adjacent to an excavation, tip or lagoon, for example the construction of a school, housing estate or road, could significantly increase the hazard. Such changes are likely to be known well in advance and should be planned for.

Reworking tips

Tips which are subject to routine geotechnical assessment may be worked or used for landscaping. It is normally appropriate to consult a geotechnical specialist, when planning such operations, since significant movement is more likely to take place when a tip is disturbed. It is good practice to retain records of what material has been placed in a tip.

53.2 Operator's duties in relation to Excavations, Tips and Lagoon which are not a Significant Hazard.

In some cases the hazards may be extremely low, for example tips/lagoons:

- ▶ which have been landscaped and the risks of failure are minimal, or
- ▶ which are immediately surrounded on all sides by higher stable ground, so that it is not possible for the tipped or stored material to move.

Such tips/lagoons are not likely to require geotechnical assessment or further appraisal.

Some such tips/lagoons may no longer be on quarry premises, for example, if they are part of a farm or industrial development, such tips/lagoons will not be subject to the Regulations and the only duty on the quarry operator is to make sure that they are safe when they are handed over to the farmer or developer. Since this does not mean that a tip/lagoon could not later become unsafe, any information which might assist a purchaser to identify and avoid risks needs to be passed on.

54. APPLICATION (Regulation 56)

56. In this Part “air receiver” means any of the following:

- (a) a vessel for containing compressed air and connected with air compressing plant, other than -
 - (i) a pipe,
 - (ii) a coil, or
 - (iii) an accessory, fitting or other part of a compressed air plant,
- (b) a fixed vessel for containing compressed air or compressed exhaust gases and used for the purpose of starting an internal combustion engine,
- (c) a vessel forming part of the equipment of a vehicle at a quarry for containing compressed air and used to operate the braking system of the vehicle,
- (d) a vessel (not being part of a spraying pistol) used for the purpose of spraying, by means of compressed air, paint, varnish, lacquer or similar material,
- (e) a vessel in which oil is stored and from which it is forced out by compressed air.

This sets out the meaning of an “air receiver” in relation to a quarry and equipment that might be found at a quarry. It includes what would traditionally be understood as air receivers and explicitly extends the meaning to cover several other vessels such as; vessels containing gases used to start engines and operating braking systems, vessels containing paint, varnish, oil etc.

55. SAFETY PRECAUTIONS (Regulation 57)

57.

- (1) Subject to paragraph (2), the operator shall ensure that every air receiver at a quarry -
 - (a) has the safe working pressure marked on it so as to be plainly visible,
 - (b) in the case of an air receiver connected with the air compressing plant, is either constructed so as to withstand with safety the maximum pressure that can be obtained

in the compressor, or is fitted with a reducing valve or other suitable appliance to prevent the safe working pressure of the air receiver being exceeded,

- (c) is fitted with a suitable safety valve adjusted so as to permit the air to escape as soon as the safe working pressure is exceeded,
 - (d) is fitted with an accurate pressure gauge indicating the pressure in the air receiver,
 - (e) is fitted with a suitable appliance for draining the air receiver,
 - (f) is fitted with a blow-off cock through which any fluid that may have accumulated in the air receiver may be blown off,
 - (g) is provided with a suitable manhole, handhole, or other means that will allow the interior of the air receiver to be thoroughly cleaned, and
 - (h) in a case where more than one air receiver is in use at the quarry, bears a distinguishing mark that is easily visible.
- (2) The requirement of paragraph (1)(e) shall not apply to an air receiver referred to in Regulation 56(d) or (e) and the requirement of paragraph (1)(g) shall not apply to an air receiver referred to in Regulation 56(c).
 - (3) For the purpose of paragraph (1) relating to safety valves and pressure gauges and subject to paragraph (4), any set of 2 or more air receivers supplied with air through a single pipe may be treated as one air receiver.
 - (4) In a case where a reducing valve or other suitable appliance to prevent the safe working pressure being exceeded is required to be fitted to a set of air receivers supplied with air through a single pipe, paragraph (3) shall not apply unless the valve or appliance is fitted on the single pipe.

The provisions of Part 7 of these Quarries Regulations 2008 are identical to the corresponding provisions of the Quarries (General) Regulations 1974 (S.I. No. 146 of 1974), except that the obligation to comply with them is transferred from the quarry manager to the quarry operator.

The requirements for air receivers include;

- ▶ A safe working pressure is clearly marked,
- ▶ A safety valve is installed,
- ▶ The receiver is fitted with a suitable safety valve,
- ▶ The receiver is fitted with an accurate pressure gauge indicating the pressure in the receiver,
- ▶ The receiver is fitted with a suitable appliance for draining the receiver,
- ▶ The receiver is fitted with a blow-off cock, through which any fluid that may have accumulated in the receiver may be blown-off,
- ▶ The receiver is provided with a suitable manhole, handhole, or other means which will allow the interior of the receiver to be thoroughly cleaned,
- ▶ In a case where more than one receiver is in use at the quarry, each must bear a distinguishing mark that is easily visible,

56. MAINTENANCE AND EXAMINATION (Regulation 58)

58.

- (1) *The operator shall take all practicable steps to ensure that every air receiver at a quarry and its fittings are of sound construction and properly maintained and that the blow-off cock fitted thereto is opened, while the plant is running, at least once in every working day.*
- (2) *The operator shall ensure that every air receiver at a quarry is thoroughly cleaned and examined by a competent person at least once in every period of 2 years, but in the case of an air receiver so constructed that the internal surface cannot be thoroughly examined -*
 - (a) *the person making any such examination may specify in writing a period exceeding 2 years but not exceeding 4 years within which the next examination is to be made, and*
 - (b) *a suitable hydraulic test of the air receiver is carried out in lieu of the internal examination.*
- (3) *A person carrying out an examination and test under paragraph (2) shall -*
 - (a) *promptly prepare a report containing the*

particulars as set out in Schedule 4, and

- (b) *within 24 hours of completing the examination, provide the report, or a copy thereof, to the person on whose behalf the inspection was carried out.*
- (4) *Where a report under this Regulation specifies that the safe working pressure of the air receiver to which it relates is to be reduced, or that such air receiver cannot continue to be safely used unless specified repairs are carried out, the operator shall ensure that the air receiver is not used until it is rendered safe, and within 7 days of receiving the report, cause a copy of the report to be sent to the Authority.*
- (5) *If an inspector is not satisfied as to -*
 - (i) *the competence of the person who carried out an examination under this Regulation, or*
 - (ii) *the thoroughness of the examination carried out, he or she may require the air receiver to be re-examined by a competent person nominated by him or her, and the operator shall make the necessary facilities available for such re-examination.*
- (6) *If, as a result of any re-examination under paragraph (5) it appears that the report of the examination under paragraph (2) was inadequate or inaccurate in any respect, the cost of the re-examination shall be recoverable by the Authority from the operator as a simple contract debt in any court of competent jurisdiction and in any legal proceedings the report of the re-examination purporting to be signed by the person making it shall be received in evidence of the facts stated therein without further proof unless the contrary is shown.*

These provisions are generally self explanatory and set out the maintenance, inspection and examination regime required for air receivers used at a quarry or on vehicles and machinery at the quarry. It specifies that the operator must ensure that every air receiver and its fittings are of good construction and properly maintained. That the blow-off cock is opened once every day while the plant is running.

It specifies that every air receiver at a quarry must be thoroughly cleaned and examined by a competent

person at least once in every period of two years.

Where the internal surface of an air receiver can not be examined this period of test may be extended by the competent person to up to 4 years, however a suitable hydraulic test must be carried out within that period.

Every examination and test must be carried out by a competent person and a report (containing the items set out in Schedule 4 to the regulations (Appendix 4)) of the result of every such examination and test must be made in writing. The competent person must provide this report to the operator within 24 hours of the examination and test.

Where it is specified that the air receiver can not continue to be used safely or that the safe working pressure is reduced the operator must prevent its use until it is made safe. Additionally, the operator shall forward a copy of any such report to the Health and Safety Authority within 7 days of receiving the report.

Provisions also allow an Inspector of the Authority to have an air receiver re-examined and the cost of such re-examination is recoverable from the operator.

**57. HEALTH HAZARDS
(Regulation 59)**

59.

- (1) *The operator, where persons are liable to be exposed to any chemical, physical or biological hazard to such an extent as is liable to be dangerous to health, shall ensure that appropriate preventive measures are taken at the quarry against that exposure.*
- (2) *The preventive measures referred to in paragraph (1) shall include -*
 - (a) *wherever possible, the replacement of a hazardous substance by a harmless or less hazardous substance,*
 - (b) *technical measures applied to the plant, machinery, equipment or process, or*
 - (c) *where it is not possible to comply with subparagraph (a) or (b), other effective measures, including the use of personal protective equipment and protective clothing.*

Workplace health covers a range of topics relating to the effect of work on health and wellbeing and vice versa and the emphasis is on prevention of ill-health due to work involving possible exposure to chemical, physical or biological hazards. Workers need to be able to work in an environment which does not compromise but rather protects and promotes their health. Also a worker's individual health and wellbeing should not impact on work quality and productivity.

Workplace health includes addressing physical issues such as manual handling and ergonomics, which if not properly managed can result in back and upper limb injuries. Other physical agents such as vibration, noise, non-ionizing radiation etc must be considered and managed by the operator so that the health of workers is protected.

It also includes traditional workplace diseases such as dermatitis, asthma and noise induced hearing loss. In recent year's psycho-social topics such as stress, bullying and behaviour at work have assumed an increased importance in protecting workers health and wellbeing.

The last line of defence in relation to protecting workers health should be the consideration of personal protective equipment and clothing.

Diesel Engine Exhaust Emissions now fall into the category of a carcinogen and an occupational exposure limit has been set in 2020 at 0.05 mg/m³ (8 hour reference period) so there is now a much greater responsibility on the Operator to prevent, remove or dilute Diesel Engine Exhaust Emissions. The Occupational Exposure Levels for Nitric Oxide and Nitrogen Dioxide which are also produced by diesel engines have also significantly reduced and as of 2020 were set at

Substance	Occupational Exposure Limit Value (8 hour reference period)		Occupational Exposure Limit Value (15-minute reference period)	
	ppm	mg/m ³	ppm	mg/m ³
Nitrogen dioxide	0.5	0.96	1	1.91
Nitric oxide	2	2.5	-	-

**58. ATMOSPHERIC INFLUENCES
(Regulation 60)**

60. *The operator shall ensure that persons working outdoors at the quarry are protected against atmospheric conditions that could affect their safety and health.*

This requires the operator to protect workers from atmospheric conditions which could adversely affect workers health and safety while working outdoors. This might range from slippery conditions due to frost underfoot to possible effects of extended exposure to sunlight. This would also include possible health and safety effects arising from conditions such as excessive cold, heat, humidity etc. It would also extend to protecting workers from risks to their safety and health arising from heavy fog, low cloud, downpours of rain, sleet or snow all of which could affect visibility; risks arising from storm conditions such as thunder, lightning and very strong winds would also need consideration.

59. DISPOSAL OF WASTE (Regulation 61)

61. *The operator shall ensure that waste from the quarry is not -*
- (a) *destroyed, or*
 - (b) *otherwise disposed of in a manner liable to be injurious to the safety and health of persons.*

This would cover a wide range of issues, everything from the destruction or disposal of waste packaging from explosives (dealt with earlier) to the destruction or disposal of waste oils, filters, brake pads, tyres, chemical drums, chemicals, waste water, sanitary waste, first aid waste, canteen waste, etc..

60. STATIONARY INTERNAL COMBUSTION ENGINES AND EXHAUST GASES (Regulation 62)

62. *The operator shall ensure that -*
- (a) *no stationary internal combustion engine is used at the quarry in any enclosed or confined place, unless specific provision is made for conducting the exhaust gases from the engine into the open air, or*
 - (b) *any such enclosed or confined place is adequately ventilated so as to prevent danger to health from the exhaust gases.*

Exhaust gases from internal combustion engines will contain gases, fumes, particulates, etc. that may have both immediate and/or long term effects.

This regulation requires the operator to ensure that all engine exhaust gases from stationary internal combustion engines in enclosed or confined places of work such as workshops are conducted to the open air so as to protect the safety and health of workers. One of the principal gases produced in engine exhaust is Carbon Monoxide, a poisonous, colourless, odourless, tasteless and non-irritant gas which is lighter than air and generated by incomplete combustion (due to lack of or insufficient oxygen mix). Carbon monoxide is created by the incomplete combustion of any carbon based fuel such as petrol, diesel, liquefied petroleum gas (LPG) and is often referred to as a silent killer.

The signs or symptoms of carbon monoxide exposure copy many common illnesses and can easily be confused with flu or simple tiredness. At low

levels, carbon monoxide exposure may cause poor concentration, memory and vision problems, and loss of muscle coordination. At higher levels, it may cause headaches, fatigue, vomiting and nausea. At very high levels, the symptoms intensify and it can kill within a matter of hours.

Carbon monoxide poisoning can be reversed if it is caught in time, however long term exposure to low levels of carbon monoxide may produce heart disease and damage to the nervous system.

Exhaust gases from internal combustion engines also contain soot and carbon particulates which are carcinogenic and can have serious long term health effects if inhaled over extended periods.

61. HEALTH SURVEILLANCE (Regulation 63)

63. *Where an employer at a quarry makes health surveillance available to persons at work in accordance with section 22 of the Act, he or she shall ensure that such health surveillance is made available before those persons are assigned to particular work activities in the quarry.*

Section 22 of the Safety, Health and Welfare at Work Act 2005 requires employers to provide appropriate health surveillance for their employees, having regard to the risks they face.

This regulation requires that a pre-employment medical examination is conducted in addition to the existing employment health surveillance. Health surveillance is also required when someone transfers to a new job within the quarry, if this means that they will be exposed to a different health risk, for example, if they begin work in a dusty or noisy area.

Conducting health surveillance on someone before they begin to carry out a particular task provides a base line from which to determine the effect of health risks at the quarry. Routine health surveillance can ensure that adverse health effects are determined at an early stage to allow appropriate action to be taken.

Quarrying can potentially expose a person to noise, dust, vibration and chemicals. The Operator should consider the physical agents that a person could be exposed to and in addition to preventing or reducing exposure they should consider health surveillance and monitoring as a means of measuring exposure.

Spirometry can provide lung function data and can determine if there is abnormal reduction in lung function, which could be as a result of exposure to dust or chemicals.

Periodic audiometry can also determine if a person is suffering from irreversible noise induced hearing loss. Both Audiometry and Spirometry are best used when a pre-employment baseline has been made.

Whole-body vibration (WBV) is the vibration and shock felt when sitting or standing on a vehicle or machine, travelling over rough ground or along a track, or the vibration when working near powerful machinery such as a rock crusher. Shocks can occur, for example, when driving over bumps or potholes. Exposure to WBV at low levels is unlikely on its own to cause back injury, but it can aggravate existing back injuries which may cause pain. There is additional information available on the Quarrying Section of the HSA website about whole body vibration. It is important that Operators provide information and training on how to minimise exposure to WBV and shock and how to recognise and report symptoms.

Exposure to some chemicals can cause sensitisation, which could lead to asthma or dermatitis; this, in the case of dermatitis could include items such as cement that contains chromate's, epoxy resins used for repairs or backing crushers, chemicals containing formaldehyde, and some adhesives.

Single, very high exposure to acids or smoke can result in Irritant Induced Occupational Asthma even where there had been no previous history of asthma.

A respiratory sensitiser is a substance which when breathed in, can trigger an allergic reaction in the respiratory system. Initial sensitisation does not usually take place immediately, it happens after a period of perhaps weeks or months of inhaling the sensitiser. Respiratory sensitisers have the following risk phrase and number in chemical safety data sheets "may cause sensitisation by inhalation (R42) ". Epoxy resins, adhesives and isocyanates would be examples of respiratory sensitisers. At pre-employment stage it would be beneficial to establish if a person had a history of dermatitis or asthma if there was the potential for exposing them to sensitisers.

62. SHELTERS AND ACCOMMODATION FOR CLOTHING AND FOR TAKING MEALS (Regulation 64)

64.

- (1) *The operator shall ensure that, subject to paragraphs (2) and (3), there is provided at or in the immediate vicinity of the quarry for the use of persons at work and conveniently accessible to them -*
- (a) *adequate and suitable enclosed accommodation for taking shelter during interruptions of work owing to bad weather and for depositing clothing not worn during working hours, being accommodation containing, where practicable, adequate and suitable means of enabling such persons to warm themselves and to dry wet clothing,*
 - (b) *adequate and suitable accommodation for the deposit of protective clothing used for work and kept, when not in use, at or in the immediate vicinity of the quarry with such arrangements as are practicable for drying such clothing if it becomes wet,*
 - (c) *adequate and suitable accommodation affording protection from the weather and including sufficient tables with impermeable surfaces and seats with backs for taking meals,*
 - (d) *facilities for boiling water and, where there are more than 5 persons at work at a quarry and heated food is not otherwise available at the quarry, adequate facilities for heating food, and*
 - (e) *an adequate supply of potable drinking water and possibly another suitable non-alcoholic beverage at a convenient point or convenient points.*
- (2) *For the purposes of paragraph (1), in determining whether accommodation is conveniently accessible, account shall be taken of any transport provided for the persons at work.*
- (3) *For the purposes of paragraph (1)(c), in determining whether accommodation of any kind provided in pursuance of that subparagraph at any time and place is adequate, account shall be taken of the number of persons at work who appear likely to use*

such accommodation at that time and place.

- (4) *The operator shall ensure that all accommodation provided in accordance with this Regulation is -*
- (a) *properly ventilated, adequately lighted, kept in a clean, hygienic and orderly condition, and*
 - (b) *not used for the deposit or storage of materials or plant.*

Due to the outdoor nature of work at quarries operators are required to provide adequate and suitable accommodation for depositing clothing not worn at work and for taking shelter from bad weather. The accommodation should, where practicable, allow workers to dry wet clothing and warm themselves. Similarly the operator is required to provide accommodation for storage and drying personal protective equipment (PPE).

The accommodation must be enclosed and provide protection from the elements with adequate tables and seating. Any seating provided should be suitable chairs with a back and not a bench.

The employer is required either to provide suitable and adequate facilities to allow employees to eat and drink any meals or beverages, or to have arrangements in place to allow employees access to other suitable and adequate facilities (such as where there is a common facility shared by employees of a number of employers in or at the same location). Any facilities provided or made available for use by employees must have means for boiling water. Where more than 5 persons are at the place of work and hot food is not available at the quarry, the operator must provide a means of heating foods such as a microwave.

The employer is required to provide an adequate supply of wholesome drinking water or other non-alcoholic beverages at locations within the quarry that are accessible to employees. The number of locations would be dependent upon the size of the quarry, the number of persons employed, the nature of the work and any requirement for the employee to remain at the workstation for sustained periods. Where drinking fountains are used, they should be of such design that the nozzle is shielded to protect it from contamination by the mouths of users.

Facilities should be kept clean and hygienic with table and other surfaces easy to clean. Sitting facilities

should have back supports and be in good condition and damaged tables or chairs should be replaced without delay. The area should have adequate ventilation, lighting and heating. Meals must not be taken in areas where there is a risk of contamination from substances used at work, vehicle fumes, etc. Such facilities must not be used for storage of any materials or plant.

63. CHANGING ROOMS AND LOCKERS (Regulation 65)

65.

- (1) *An operator shall provide or cause to be provided -*
 - (a) *appropriate changing rooms for persons at work if they have to wear special work clothes and if, for reasons of health or propriety, they cannot be expected to change in another area, which are -*
 - (i) *easily accessible,*
 - (ii) *of sufficient capacity, and*
 - (iii) *provided with seating,*
 - (b) *separate changing rooms or separate use of changing rooms for men and women, and*
 - (c) *adequate provision for drying wet or damp work clothes.*
- (2) *If circumstances so require where work clothes are likely to be contaminated by dangerous substances, atmospheric conditions or the conditions of the place of work, the operator shall provide, or cause to be provided, facilities in changing rooms to enable working clothes to be kept in a place separate from personal clothing and effects.*
- (3) *If changing rooms are not required as referred to in paragraph (1), the operator shall ensure that every person at work is provided with a place to store his or her own clothes and personal effects.*

Changing rooms should be sufficiently large and have facilities to enable each person at work to lock away his or her clothes during working hours and if the nature of the work so requires (e.g. drilling, crusher station, mechanical maintenance, laboratory, etc.) separate lockers for work clothes should also be provided.

When changing rooms are provided, they should:

- ▶ be readily accessible from workrooms,
- ▶ be provided in conjunction with any shower or bathing accommodation, and have easy communication with it,
- ▶ have easy communication with the clothing accommodation,
- ▶ contain adequate seating,
- ▶ be conveniently situated for the use of employees using facilities for taking meals.

For offices workers and for certain other employees, satisfactory changing facilities may consist of separate pegs or hooks at least 31 cm apart laterally for each employee for outer clothing such as coats, coveralls or aprons, which can be changed in workrooms where there are no risks to health and safety. In addition, some provision for personal effects must be made.

Provision needs to be made to dry clothing or overalls that have become damp due to the nature of the work.

Where extensive changing is necessary, separate cloakroom facilities must be provided for men and women except when the facilities are provided in a room intended to be used by only one person, the door of which is capable of being secured from the inside.

64. WASHING FACILITIES (Regulation 66)

66.

- (1) *The operator shall ensure that adequate and suitable facilities for washing appropriate to the numbers of persons at work and the duration of the work are provided at the quarry, including -*
 - (a) *adequate troughs or washbasins having in every case a smooth impervious internal surface,*
 - (b) *adequate and suitable means of cleaning and drying, being either soap and towels or other means, as the case may require, and*
 - (c) *a sufficient supply of hot and cold or warm running water.*
- (2) *The operator shall ensure that -*
 - (a) *washing facilities provided are conveniently accessible from the accommodation for taking meals and are adequately lighted,*

properly ventilated and are kept in a clean and orderly condition,

- (b) provision is made for separate washbasins, or separate use of washbasins for men and women when so required for reasons of propriety,*
- (c) suitable showers in sufficient numbers are provided for persons at work, if required by the nature of the work or for health reasons,*
- (d) provision is made for separate shower rooms or separate use of shower rooms for men and women,*
- (e) the shower rooms are sufficiently large to permit each person to wash without hindrance in conditions of an appropriate standard of hygiene and such showers are equipped with hot and cold running water, and*
- (f) where the rooms containing showers or washbasins are separate from changing rooms, there is easy access between the two.*

To be adequate and suitable, facilities for washing should include running hot and cold, or warm, water as well as soap and clean towels (the single towel for use by many should be discouraged) or other suitable means of cleaning or drying. Washing facilities should be conveniently located, be near to the sanitary facilities and large enough to facilitate washing of face, hands and forearms.

Separate washing facilities and/or showers should be provided for men and women except when the facilities are provided in a room intended to be used by only one person, the door of which is capable of being secured from the inside. Separate facilities are not necessary for washing the hands, forearms and face only.

Hot water temperatures must be controlled so as to prevent scalding.

Showers are necessary where workers are exposed to heavy physical work or to offensive/harmful substances where ongoing skin and hair contamination must be prevented.

The provision of emergency showers is sometimes required under other legislation for first-aid purposes such as when handling acids or alkalis.

Washing facilities should have adequate lighting, be

sufficiently ventilated, adequately protected from the weather, appropriately maintained and kept clean. Employers may arrange amongst themselves to jointly provide and maintain facilities.

65. SANITARY CONVENIENCES (Regulation 67)

67.

- (1) The operator shall ensure that adequate and suitable sanitary conveniences appropriate to the number of persons at work at the quarry are provided.*
- (2) The operator shall ensure that -*
 - (a) every sanitary convenience, other than a convenience suitable only as a urinal, has a proper door fastening and is partitioned off to secure privacy,*
 - (b) every sanitary convenience required to be provided is sufficiently ventilated and does not communicate with any workroom or mess room except through the open air or through an intervening ventilated space,*
 - (c) every sanitary convenience is under cover,*
 - (d) the sanitary conveniences are so arranged as to be conveniently accessible to persons at work at all times while they are at the quarry and are, where practicable, convenient to the washing facilities,*
 - (e) provision is made for separate sanitary conveniences or separate use of sanitary conveniences for men and women, and*
 - (f) every sanitary convenience is maintained in a clean and hygienic condition.*

BS 6465-1:2006, "Code of practice for the design of sanitary facilities and scales of provision of sanitary and associated appliances" provides guidance for determining an adequate number of lavatories and washbasins.

The tables below which relate to staff facilities in offices, shops, factories and other non-domestic premises are taken from the above standard. Other types of workplaces are also addressed in the publication.

The numbers of employees mentioned below refer to the maximum number likely to be in the place of work at any one time. Where separate facilities are provided

for a group of employees, for example men, women, office workers or manual employees, a separate calculation should be made for each group.

If the work leads to heavy contamination of hands or forearms, the number of washbasins may need to be increased to 1 per 10 persons at work up to 50 persons and 1 per 20 thereafter.

Sanitary facilities which are not suitably mechanically ventilated, must not exit into any workroom except through the open air or through an intervening ventilated space.

Sanitary facilities should be located either on the same floor in a place of work or either one floor above or below the place of work unless a passenger lift gives access to other floors.

Separate sanitary facilities should be provided for men and women except when the facilities are in a room, lockable from the inside and accommodating one person only at a time.

Toilets for staff should be in addition to and separate from toilets for other users.

Doors to WC compartments should be equipped with locks that can be easily operated by the user and readily released from outside in case of an emergency.

WC compartments and urinals should not be visible from outside the toilets.

WC compartments should be supplied with toilet paper and hooks so that clothing does not have to be placed on the floor.

Female toilet compartments should be supplied with a suitable sanitary disposal unit.

If WC bowl fittings become loose they need to be secured to prevent them falling over.

The Building Regulations Technical Guidance Document M provides advice on sanitary conveniences designed for use by people with disabilities.

66. SAFE ACCESS TO PLACES WHERE FACILITIES ARE PROVIDED (Regulation 68)

68. *The operator shall ensure that -*

- (a) *safe means of access and egress is provided and maintained to and from every place at which any facilities provided in accordance with this Part are situated, and*

- (b) *every such place is made and kept safe for persons using such facilities.*

The operator is required to provide and maintain access to and egress from any facilities provided under this part. Such access and egress must be kept in a safe condition for persons using these facilities. This requires that the area around such facilities be kept clear with good underfoot conditions so as to minimise dirt entering facilities. Properly constructed steps and/or ramps should be provided and the placing of pallets, timber, loose blocks, etc which can cause persons to trip should not be used to provide access to facilities.

67. PREGNANT WOMEN AND NURSING MOTHERS (Regulation 69)

69. *The operator shall ensure that pregnant women and nursing mothers at work at the quarry are provided with appropriate facilities as set out in other relevant legislation.*

The facility for pregnant women and nursing mothers should, when possible, be situated near the welfare facilities, i.e. toilet and washing facilities and be equipped to allow persons to lie down. Adequate space, heating and lighting are required.

68. PERSONS WITH DISABILITIES (Regulation 70)

70. *The operator shall, where necessary, ensure that a quarry is organised to take account of persons at work with disabilities, in particular as regards doors, passageways, staircases, showers, washbasins, lavatories and workstations used or occupied directly by those persons.*

Accessibility for persons with disabilities is covered by Part "M" of the Building Regulations entitled "**Access for People with Disabilities**". It is to ensure that as far as is reasonable and practicable, buildings should be usable by people with disabilities. It comes in three sections, which include access and use, sanitary conveniences and audience and spectator facilities. The Building Regulations apply to construction of new buildings after 1 January 2001 and any extension work or renovations carried out after that date.

In addition, certain parts of those Regulations apply to existing buildings where a material change of use

takes place. Otherwise, the Building Regulations do not apply to buildings constructed prior to 1 June 1992. Egress in the event of an emergency for people with disabilities is referred to in Technical Guidance Document B.

Where the Building Regulations do not apply to existing buildings, safe access to, egress from and circulation within the workplace for employees with disabilities should be provided, as necessary. Access to all welfare areas should also be provided.

Employers should ensure that adequate assistance should be provided for the safe evacuation of those with a disability in the event of an emergency.

Guidance is also available in BS "5588: Fire precautions in the design, construction and use of buildings Part 8: Code of practice for means of escape for disabled people".

Due to the variety of design options in facilitating access and safety for people with disabilities, and the

wide range of disabilities and their varying degrees of effect, specialist advice should be sought.

The National Disability Authority has issued guidelines, for the built and external environment in a publication entitled, "**Building for Everyone**". It may be contacted at the Authority's offices at 25 Clyde Road, Ballsbridge, Dublin 4 (01 - 6080400) or through it's website at www.nda.ie.

69. REST ROOMS (Regulation 71)

71. The operator shall ensure that -

- (a) where necessary, and in particular, where the number of persons at work requires it, they are provided with an easily accessible rest room,
- (b) rest rooms are large enough and equipped with tables, and with seats with backs, adequate for the number of persons at work,

Figure 45: Tables of Provision of Sanitary Facilities

Male and Female if no urinals are installed		
Number of people at work	Number of water closets	Number of washbasins
1 to 5	1	1
6 to 15	2	2
16 to 30	3	3
31 to 45	4	4
46 to 60	5	5
61 to 75	6	6
76 to 90	7	7
91 to 100	8	8
Above 100	8 +1WC and washbasin per 25 persons or fraction thereof	

Alternative provision for male staff only if urinals provided			
Number of men at work	Number of water closets	Number of urinals	Number of washbasins
1 to 15	1	1	1
16 to 30	2	1	2
31 to 45	2	2	2
46 to 60	3	2	3
61 to 75	3	3	3
76 to 90	4	3	4
91 to 100	4	4	4
Above 100	4+ 1WC, urinal and washbasin per 50 males or fraction thereof.		

and

- (c) if working hours are regularly and frequently interrupted and there is no specific rest room, other rooms are provided in which persons at work can stay during such interruptions, where this is required for their safety or health.*

The need to provide rest rooms would arise where arduous physical activity is involved or work in a hostile environment involving exposure to dust, fumes, noise or excessive heat or cold. The underlying principle is that employees should not spend all their time at work in damaging environments.

Rest rooms should be provided away from work areas where the workstations or workrooms are dirty, contaminated, noisy or subject to disturbances, e.g. block plants, crusher houses, ready-mix plants etc. This requirement does not apply to employees in offices or similar workstations where relaxation during breaks is provided for.

If a canteen is used, employees who wear contaminated work clothes during their rest period should use a dedicated rest room rather than the canteen to avoid contaminating the canteen facilities.

Canteens or restaurants may be used as rest facilities, provided that there is no obligation to purchase food in order to use them.

If workers must frequently leave their work area for short periods, e.g., resetting equipment etc., there should be a suitable rest area provided where they may wait.

SCHEDULE 1**(See Regulations 2(3) & 13(c))****QUARRIES SKILLS CERTIFICATION SCHEME**

1.

(1) *The requirement for the issue of a FETAC award under the Quarries Skills Certification Scheme (referred to in this Schedule as the "Scheme") is successful completion of training under the Scheme in any of the following tasks:*

- (a) *slinging and signalling;*
- (b) *telescopic handler operation;*
- (c) *tractor and dozer operation;*
- (d) *mobile crane operation;*
- (e) *crawler crane operation;*
- (f) *articulated dumper operation;*
- (g) *site dumper operation;*
- (h) *180° excavator operation;*
- (i) *mini-digger operation – where the person has not been trained in the task referred to at subparagraph (h);*
- (j) *360° excavator operation;*
- (k) *rigid dump truck operation;*
- (l) *front end loader operation;*
- (m) *explosives storekeeping;*
- (n) *shotfiring;*
- (o) *explosives supervision;*
- (p) *such other quarrying-related tasks as may be prescribed by the Minister.*

(2) *Where it is necessary to gain experience prior to undertaking a programme related to the tasks listed at subparagraph (1) it is permissible for a person to undertake those tasks during the training period required by the programme if-*

- (a) *the person concerned is at all times under the close personal supervision of a person who is in possession of a current registration card relevant to the task concerned, and*
- (b) *the person concerned is in possession of an appropriate identification identifying the person as a trainee in the relevant skills and an associated documented log-book*

recording experience gained in the skill in which the person is undergoing training.

2. *SOLAS shall issue a registration card to a person who applies to it and has been awarded—*

- (a) *an award from QQI for the purpose of this Schedule in a task listed in paragraph 1(1),*
- (b) *an award from another body in the State which is recognised by SOLAS as equivalent to the award referred to in clause (a),*
- (c) *an award approved by a body in another Member State and recognised by SOLAS under the Professional Qualifications Regulations as equivalent to the award referred to in clause (a),*
- (d) *an award approved by a body in a state other than a Member State and recognised by SOLAS as equivalent to the award referred to in clause (a)*

SCHEDULE 2

Machinery subject to Regulation 23(2)(e)

Machine Type

Off-road dump trucks (trailer to rear of driver), payload greater than 7 Tonnes

Dumpers (front tip) no cab

Dumpers (front tip) with cab

Wheel loaders (loading shovels), including skid steer loaders

Backhoe loaders

All 360° excavators

Scrapers

All tracked type tractors (bulldozers)

Graders

Telescopic handlers

SCHEDULE 3
(See Regulation 55)

GEOTECHNICAL ASSESSMENTS

DOCUMENTS AND PARTICULARS TO BE INCLUDED IN
GEOTECHNICAL ASSESSMENT

Excavation, tip or lagoon.

1. *In this Schedule "excavation, tip or lagoon" includes, where appropriate, a proposed excavation, tip or lagoon.*

Site survey.

2. *An accurate plan on a scale not less detailed than 1:2,500 showing -*
 - (a) *the boundaries of the quarry upon which the excavation, tip or lagoon is or is to be situated,*
 - (b) *the site of the excavation, tip or lagoon,*
 - (c) *any contiguous land or structure that might be affected by the excavation, tip or lagoon,*
 - (d) *buried quarry workings, known cave systems, active or former landslips, springs, artesian wells, watercourses, mine workings (whether in use or not) and other natural or man-made features, including tunnel pipes or culverts that might -*
 - (i) *affect the safety of the excavation, tip or lagoon, or*
 - (ii) *be relevant for the purpose of determining whether quarrying operations can be carried out safely.*

This plan shall be contoured, orientated and correlated to the Ordnance Datum Survey National Grid at a vertical interval not greater than 5 metres and marked with squares corresponding to the 100 metre squares shown on Ordnance Survey sheets on the scale of 1:2,500.

Site investigation.

3. *A record of all relevant site investigation information including surveys, tests, boreholes and groundwater measurements made for the purpose of the geotechnical assessment together with the results of any testing including the*

strength of materials within and beneath the tip or within the excavated slope. The record shall include any known historical information relevant to the site investigation.

Cross-sections based on site investigation.

4. *Sufficient accurate cross-sections on a scale not less detailed than 1:1,250 of the site of the excavation, tip or lagoon showing the existing ground surface and all relevant superficial materials and bedrock underlying the site and -*
 - (a) *any variation in the thickness, level or character of the superficial deposits and bedrock materials based on the site investigation; and*
 - (b) *the position of any surface, whether natural or man-made, that may affect the safety of the excavation, tip or lagoon.*

Plans based on site investigation.

5. *Plans showing the position of all boreholes, wells and trial pits used in the site investigation and the location and levels of all materials and surfaces that may affect the safety of the excavation, tip or lagoon.*

Assumptions made before analysis.

6. *A record of any assumptions relevant to the assessment of ground conditions relating to the safety of the excavation or tip made by the geotechnical specialist, including a record of any relevant information that was not available when undertaking the assessment.*

Findings of analysis.

7. *A record of the calculations carried out in order to determine the safety of the excavation or tip, including any variables or parameters used in those calculations and the reasons for using them and the findings of those calculations expressed as the factor of safety or the probability of failure or other recognised basis of assessing stability.*

APPENDIX 3

Design coming out of analysis.

8. *An accurate plan on a scale not less detailed than 1:2,500 recording -*
 - (a) *in relation to an excavation, the design of the excavation, including the height or proposed height of the slope, the position and width of any benches and representative contours of the excavation at vertical intervals of not more than 5 metres, and*
 - (b) *in relation to a tip or lagoon, the design of the tip or lagoon, including the area of land covered or to be covered, the gradients of that land, the designed contours at vertical intervals of not more than 2 metres, the side slopes and boundaries of the tip or lagoon and the designed position and nature of construction of any wall or other structure retaining or confining the tip, or lagoon.*

Requirements during and after quarrying operations.

9. *A report of the nature and extent of inspection, supervision and safety measures necessary to ensure the safety of the excavation, tip or lagoon and a specification of necessary engineering works and safety measures. A record of the action to be taken regarding defects shall be specified in the report.*

SCHEDULE 4
(See Regulation 58)

AIR RECEIVERS

PARTICULARS TO BE INCLUDED IN REPORT OF EXAMINATION OF AIR RECEIVER

1. *Name of operator of quarry.*
2. *Name and address of quarry.*
3. *Description, distinguishing mark and type of the air receiver.*
4. *Date of construction (if ascertainable) together with a brief history of the air receiver.*
5. *Date of last hydraulic test (if any) and pressure applied.*
6. *Particulars of -*
 - (a) *inaccessible parts (if any) at the time of examination,*
 - (b) *the examination and test made,*
 - (c) *its condition, including particulars of any defect materially affecting the safe working pressure.*
7. *Particulars as to whether the fittings and appliances are properly maintained and in good condition.*
8. *Particulars of the safe working pressure calculated from dimensions, thickness and other data as ascertained during the examination, taking account of unusual or exceptionally severe working conditions.*
9. *Particulars of -*
 - (a) *repairs (if any) required,*
 - (b) *the period within which the repairs should be carried out, and*
 - (c) *any other requirements that the person making the examination considers necessary.*
10. *Where repairs affecting the safe working pressure are required under paragraph 9, particulars of the safe working pressure that shall apply to the air receiver -*
 - (a) *before the expiration of the period specified in paragraph 9(b),*
 - (b) *after the expiration of such period, if the required repairs have not been completed, and*
 - (c) *after the completion of the required repairs.*
11. *The date of the examination and the name of the competent*

Guidance Documents and Information Sheets

- Identifying Significant Hazards in Quarries
- Quarry Vehicle Brakes Maintenance And Testing
- Fall Protection at the Top of the Quarry Face
- Client and Contractor Code of Conduct at Quarrying Locations
- Inflation of Quarry Vehicle Tyres

Identifying Significant Hazards

Regulation 54 Safety, Health and Welfare at Work (Quarries) Regulation 2008

Information Sheet

November 2017

Regulation 54 of the Safety, Health and Welfare at Work (Quarries) Regulations 2008 requires the Operator to have a suitable appraisal of all proposed and existing excavations, tips and lagoons undertaken by a competent person. The frequency of appraisals should be identified in the Operating procedures for the Quarry. The appraisal should identify any significant hazards or potential significant hazards and determine if they can or cannot be rectified immediately in a safe manner.

Any hazard or potential hazard should be considered significant or potentially significant if such a failure would directly or indirectly, be liable to endanger premises, roadways or other places where people are likely to be found offsite; or likely to cause serious or fatal injuries to persons on or off-site.

If the competent person is unable to determine if a hazard or potential hazard is significant or potentially significant they should seek the advice of a geotechnical specialist.

The following diagrams provide guidance to scenarios where a hazard should be considered significant or potentially significant

Working faces of sand and gravel or other weak materials such as clay where the vertical face height (H) is in excess of 7.5 metres and the overall face angle is steeper than a suitable angle to ensure safety should be considered to be or potentially be a significant hazard.

The natural angle of repose considered by extractive industry best practice as a suitable angle to ensure safety in unconsolidated material is as low as 27° or 1 in 2.

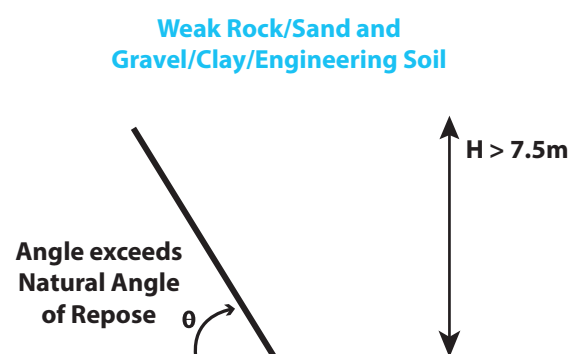

Where the face height of an excavation in a particular area of a quarry is worked or is planned to be worked exceeds 20 metres then this is a significant hazard and the Operator must ensure that a geotechnical assessment is carried out.

There are no mitigating factors, a geotechnical assessment is mandatory.

Where multiple benches have been worked or are being worked and the bench widths or the overall face angle may be inadequate to ensure quarry stability then this should be considered a significant or potentially significant hazard.

The extractive industry best practice is an overall face angle of 45° or 1 in 1 though this depends upon local conditions.

Based on extractive industry best practice the quarry face may also potentially be considered a significant hazard if the overall bench height (H_b) is greater than 30m.

If there is a structure, tip or stockpile close to the quarry face edge it should be considered that this is a significant or potentially significant hazard irrespective of any excavation face height, depth or angle. Other factors should also be considered, for example, the geology, location or proximity of a tip, location or proximity of infrastructure or private lands.

Although no minimum distance of encroachment of a quarry face to a structure, tip or stockpile is specified in the regulations any distance (L) less than 30 metres should be considered a significant or potentially significant hazard based on extractive industry best practice.

An appraisal of a tip or stockpile should indicate that the tip or stockpile should be considered a significant or potentially significant hazard if it has a vertical height in excess of 20 metres.

Moderately weak or stronger rocks

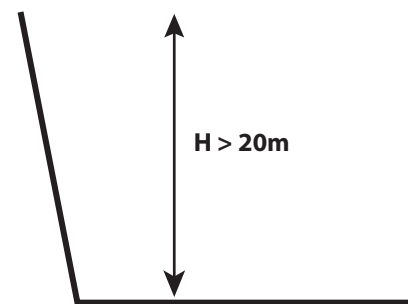

Multiple Quarry Benches

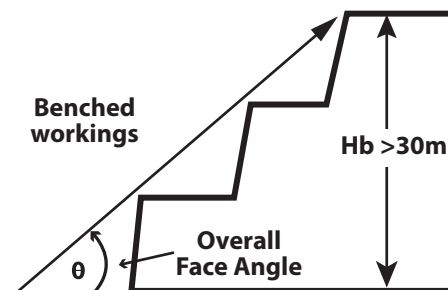

Structure, Tip or Stockpile near face edge

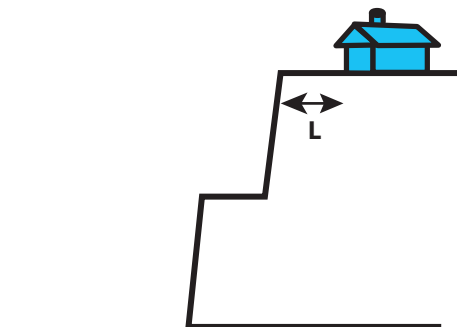

Stockpiles

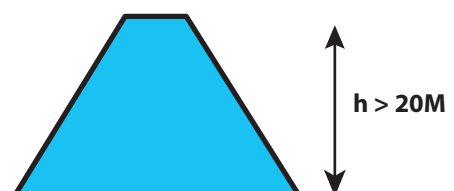

An appraisal of a tip or stockpile should indicate that the tip or stockpile should be considered a significant or potentially significant hazard if the area of the land covered by the tip or stockpile exceeds 10,000 square metres.

The calculation of the area of the tip or stockpile will be dependent upon the shape of the tip or stockpile. For illustrative purposes a simple rectangle has been used.

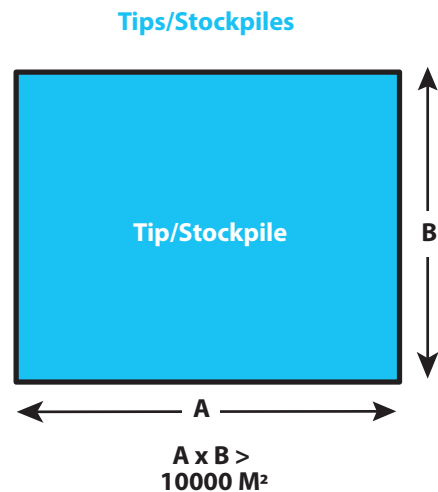

An appraisal of a tip or stockpile should indicate that the tip or stockpile should be considered a significant or potentially significant hazard if the average gradient of the land covered by the tip or stockpile exceeds 1 in 12 (8.3%).

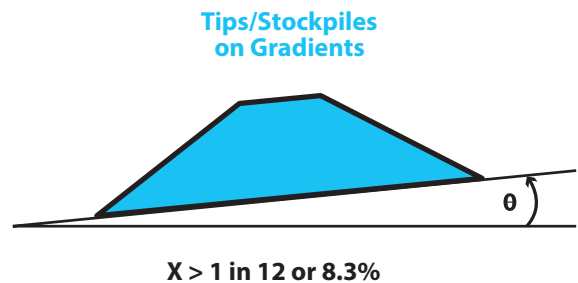

An appraisal of a pond or lagoon should indicate that the pond or lagoon should be considered a significant or potentially significant hazard if the volume of liquid contained exceeds 10,000 cubic metres.

As an example a pond/lagoon 2.5 metres deep with a width of 50 metres and a length of 80 metres when full would contain 10,000 cubic metres of liquid.

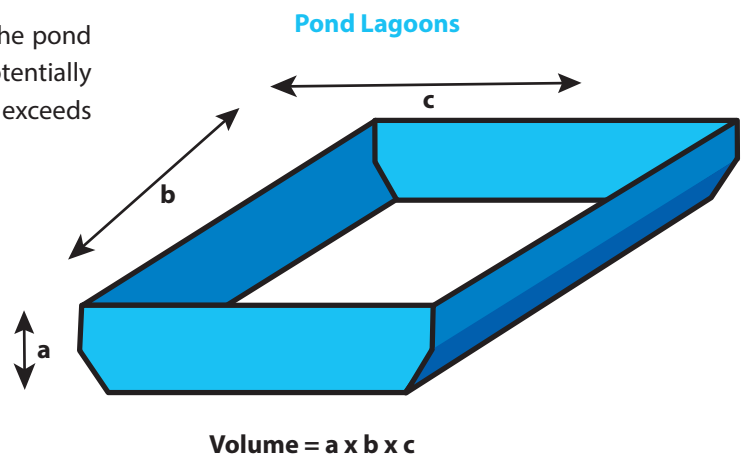

An appraisal of a pond or lagoon should indicate that it should be considered a significant or potentially significant hazard if the level of the land within 50 metres of the edge of the pond or lagoon (L) is 4 metres below (D) the land at the edge of the pond or lagoon.

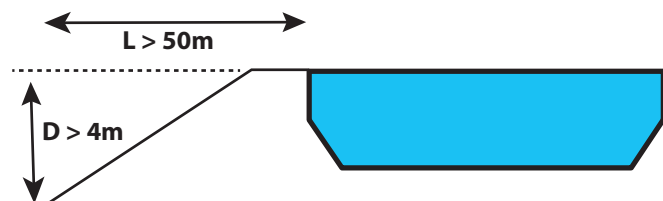

Further information

Health and Safety Authority

Workplace Contact Unit, Metropolitan Building, James Joyce Street, Dublin 1
Telephone: 1890 289 389 Email: wcu@hsa.ie Web: www.hsa.ie

Quarry Vehicle Brakes Maintenance And Testing

Information Sheet

Brakes & Braking

Quarry vehicles are very large and can cause significant damage and injury if they cannot be brought safely to a stop or controlled during operation or when parked on an incline. The quarrying environment and operations can impact on a vehicle's braking performance particularly when working on a gradient and where there are tight bends and turning circles. The design and layout of quarry roads should involve minimum gradients with gradual corners. Where possible, long-term haul roads should be hard surfaced and all other road surfaces should be regularly maintained.

Vehicle parking/service brakes should be capable of holding the vehicle on the steepest gradients that the vehicle is expected to negotiate when it is fully loaded.

Emergency Slip Roads

Emergency slip roads (i.e. gravel or sand traps) should be provided where they are necessary on long or steep declines or tight bends.

Brake Inspection & Testing

A suitable inspection scheme is required to ensure brakes are in good condition on all loading shovels, dumper trucks and some other rubber tyred vehicles such as tractors operating in the quarry. Monitoring the braking capabilities of a quarry vehicle is an essential part of vehicle safety and is closely allied with brake maintenance. Any monitoring system must start with the participation of vehicle drivers, who should carry out a series of simple checks at the start of the working day or shift and record their observations in a daily vehicle inspection book or sheet.



Before commencing work with the vehicle:

1. Check brake fluid / air gauges are at the correct operating pressure
2. Check the service and emergency brakes when setting off and again when loaded
3. Check the parking brake when stopped and facing downhill near the bottom of the steepest incline in use
4. Report any defects immediately

Brake Maintenance

The driver's daily reports reflect the condition of the vehicle braking system at that moment in time and immediate action should be taken to rectify any faults brought to light by the driver.

The testing of the service brake only checks the effective use of the brakes. It may not identify other faults in the braking system. It is for this reason that maintenance of the whole of the braking system should be carried out in accordance with the manufacturer's recommendations.

Brake maintenance schedules will not only include adjustment, fluid levels, pressures etc., they will also contain the replacement of seals and other vital components in accordance with the manufacturer's recommendations.

Emergency steering and emergency braking systems should also be included in regular inspection and testing programmes. Contractors' vehicles working in quarries should be subject to the same brake testing schemes.

Brake Testing Area

The Operator should provide a clearly signposted Brake Testing Area where vehicles can be tested on a daily basis. The test area must have "Brake start" marker post and distance marker posts so that Operators have a clear indication of the stopping distance achieved during the daily test with a final post marking the limit of acceptable 'over-run' before adjustment or brake replacement is required. The test area should be selected with consideration given to safe stopping. Different acceptable stopping distances will be necessary for dumper trucks and loading shovels.



Establishing the Expected Brake Ratio of the Vehicle

If it is a new vehicle then the manufacturer must provide adequate information including the expected brake ratio. For older vehicles where there is little or no information on braking efficiency then an electronic brake tester can be used to determine the optimum brake ratio by carrying out a number of tests following servicing of the braking system and obtaining an average value. Then a lower action level is determined at which the vehicle braking system will require further assessment or servicing.

Periodic Brake Testing Of Vehicles

Electronic brake testing is a procedure for periodically checking that a vehicles brakes are maintained (working) at a level that does not put people at risk. The electronic brake tester determines braking efficiency by measuring the rate of deceleration until the vehicle comes to rest. Electronic brake testing is recommended to be carried out every 500 hours of vehicle use or every three months, whichever comes first, and the results recorded to identify any deterioration or sudden reduction in braking performance*. Usually this means:

1. ideally that the level of performance has not significantly reduced below the expected brake ratio; or
2. at the very least, that the level of performance exceeds that required for safe working under the most onerous site conditions of speed, load and gradient.

Although electronic brake testing devices are self-compensating and have built in tolerances, results can vary with different testing surfaces and weather conditions. If possible, tests should be carried out on the same or a similar surface and comparable weather conditions.

The braking capabilities of a dumper truck or loading shovel should also take account of any arduous site conditions such as gradients, road layouts and the road surface that it may operate on.

The brake ratio values given in ISO 3450 are a minimum standard for manufacturers, not a maintenance standard and may be only 50% of the expected brake ratio of some vehicles and is not acceptable as generic pass or fail criteria.*

As a rule of thumb doubling the brake ratio halves the braking distance, doubling the speed increases the stopping distance by approximately 4 times.

*This supersedes the recommendations on page 38 of the Safe Quarry Guidelines to the Safety, Health and Welfare at Work (Quarries) Regulations 2008

Electronic Brake Testing

Total reliance on the driver's daily check is not a sufficient control measure, it must be supported by regular instrumented tests completed by a competent person using an electronic brake efficiency meter. Quarries are difficult working environments and consequently brake performance will deteriorate in service. The braking ratio required for a vehicle depends upon the vehicle type and local conditions such as the gradient of the haul road, the condition of the haul road and any bends that the vehicle must negotiate. When travelling down a gradient the vehicle must overcome the weight acting on the gradient in addition to the normal braking effort in order to come to a stop.



Further Information and Guidance:

Visit our website at www.hsa.ie, telephone our contact centre on **1890 289 389** or email wcu@hsa.ie

Use BeSMART, our free online risk assessment tool at www.besmart.ie

Check out our range of free online courses at www.hslearning.ie

Fall Protection at the Top of the Quarry Face

Information Sheet

November 2017

Regulation 9 of the Safety, Health and Welfare at Work (Quarries) Regulations 2008 requires the Operator to ensure, as regards that quarry, that work is planned taking into account the elements of the safety statement that concern the risks of falls. Therefore the Operator needs to consider any activities that take place at the top of quarry faces and this would include inadvertent and unauthorised access, face profiling and surveying activities, drilling operations and shotfiring operations.

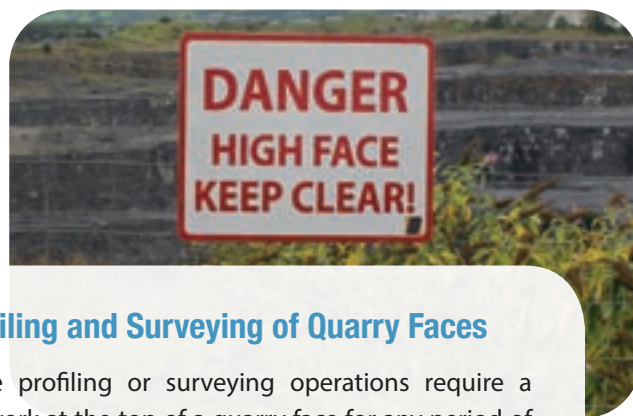

Face Profiling and Surveying of Quarry Faces

Where face profiling or surveying operations require a person to work at the top of a quarry face for any period of time then procedures must show how this is to be carried out safely. Although collective measures to prevent falls are preferable if access is occasional and only exposes an individual to the risk of falling then individual protection may be more appropriate. If the individual protection requires the use of a harness and a lanyard then:

- the person should be trained in the safe use of the harness and lanyard,
- the lanyard must be adequately secured so that it can hold the weight of the person if he was to fall,
- the lanyard must not allow the person to reach the quarry face edge, and
- the lanyard and harness must have a current certificate of thorough examination.

Inadvertent and Unauthorised Access

It can be very difficult to prevent a determined intruder entering a quarry, however the Operator has a duty under regulation 34 of the Safety, Health and Welfare at Work (Quarries) Regulations 2008 to ensure that adequate precautions are taken to prevent unauthorised entry to the quarry including, where appropriate, the provision of barriers. Quarry boundaries should be signposted and laid out so as to be clearly visible and identifiable. The Operator must review the adequacy of boundaries and barriers designed to prevent unauthorised entry to the quarry and take appropriate action where there is evidence of unauthorised entry, in addition to this signage should indicate areas where there is a risk of falling or drowning.

Drilling Operations

Where the face is to be drilled prior to blasting, the Operator must ensure that the driller is adequately protected from falling from the quarry face. Suitable procedures should generally have collective measures in place to prevent the driller from falling and where individual measures are necessary they should only be used for the purpose of erecting collective measures.

If straps and poles are the collective system specified by the Operator then the driller should ensure that short holes are drilled behind the last row of holes for the blast that will facilitate the erection of the straps and poles following the inspection of the blast. If the driller arrives on site and there is no collective system in place to prevent them from falling then the driller must wear a secured lanyard and harness. Where the lanyard must not allow the person to reach the quarry face edge, this should only be used to prepare for and for the erection of the collective system and not for the drilling of the shotholes.

Face Shothole Loading

Loading and charging must only be carried out under the supervision of the Explosives Supervisor/Shotfirer. Collective systems must be used during loading operations.

Risk Assessment for Work at a Quarry Face

It is very important to carry out a site specific risk assessment including all the personnel likely to be involved in the blasting operation such as the Driller, Shotfirer, Explosives Supervisor, Quarry Manager, Bulk Explosive Supplier, and Geotechnical Consultant.

The following topics should be considered in any risk assessment:

- The site geology and stability of the face
- Access to the blast site for drill rig, delivery of stemming, explosives delivery vehicles, bulk explosive trucks and emergency vehicles
- Prevention of personnel and equipment from falling over the edge

- Traffic management during work at the top of the quarry face
- Blast design parameters such as spacing and burden
- Profiling and surveying operations
- The weather conditions at the time when work is to be carried out

The Work at Height hierarchy should be followed in selecting the method used:

- Collective measures should be given priority over personal protective measures
- Physical barriers such as safety bund and the post and strap systems should be considered first
- Only where the use of a physical barrier creates an unacceptable risk then other measures such as delineation of the danger zone or harnesses may be considered
- The Quarry Operator should be able to show that they have considered how a fall from an open edge will be prevented for that particular blast

Collective Systems

1. Use of quarried material to create a bunded barrier at the top of the face

This method is only suitable for use where the quarry face is well managed and the geology is consistently good and would be unsuitable where burdens are less than 4 metres, or where the rock is prone to back break and cracking and where the face often has overhanging rock. This system is best suited to lower face heights where burdens are in excess of 4 metres. The burdens could be extended by increasing the diameter of the shotholes. However, the vibration will need to be monitored if the maximum instantaneous charge is increased as a result of a greater shothole diameter. In order to build an adequate barrier at least 4 metres of free face is required between the quarry face edge and the planned first row of shotholes.

If this is not available then the barrier is unlikely to be high or wide enough to prevent a person from falling and it can cause difficulty drilling the front row of shotholes as the quarried material in the barrier may flow into the shothole. The barrier must be at least 950mm above the quarry face edge at all points along its length and higher if vehicles are operating close to the face edge. The barrier must extend beyond either side of the planned front row of holes or where persons will be working and also at the sides if there is an exposed edge where a person could fall.

The quarried material in the barrier should be in place before drilling commences. This is best achieved by placing the quarried material behind the last row of holes of the planned blast so that when the blast is taken the next barrier is in place. Again this shows that the system is only suitable when faces are well managed and geology is consistent. Putting an initial barrier made of quarried material at the quarry face edge places the vehicle Operator at risk especially where the ground is shattered or there are slip planes. It is much safer to have the barrier installed behind the next blast so that only maintenance of the barrier is necessary. The sequence is explained in the diagrams below.

When using bunded edge protection account must be taken of changes in elevation across the blast site to ensure an adequate barrier is in place.

The use of quarried material as a fall barrier at a quarry face prior to blasting

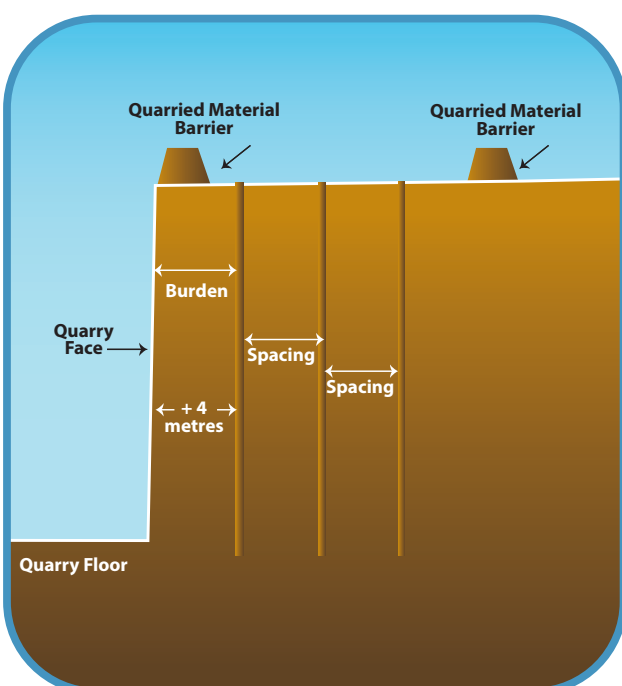

The use of quarried material as a barrier immediately following the blast

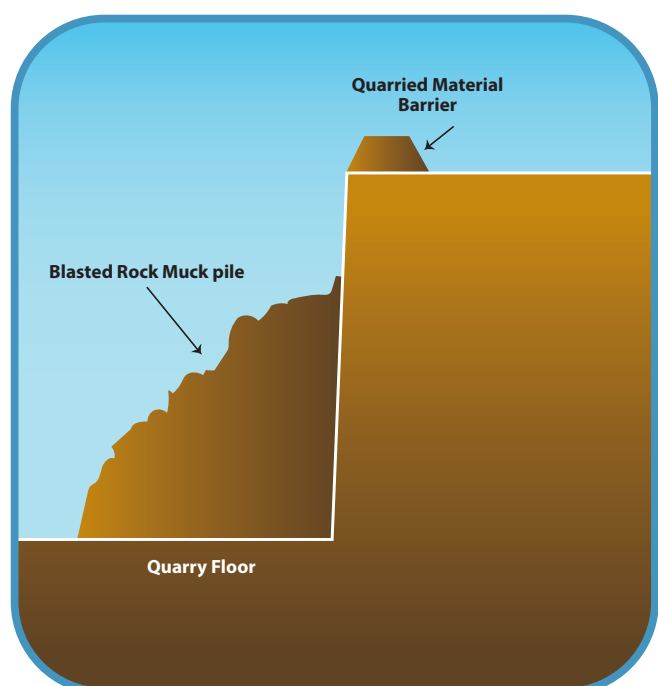

Bunded Edge Protection



Drill Rig Operator working at a Quarry Face with fall protection provided by bunded edge protection made from quarried material



Quarry Workers marking out drill holes with fall protection provided by bunded edge protection made from quarried material

Collective Systems

2. Straps and Poles

This is an accepted method for providing fall protection at a quarry face. This system must be well managed to ensure it provides adequate protection when persons are working at the quarry face. The top strap must be at least 950 millimetres above the edge of the quarry face and the lower strap must not be more than 470 mm below the top strap.

The straps must be adequately tensioned so that a person cannot fall through them. The top and lower strap should be connected by intermediate bands or other means to maintain a constant distance between the straps. If ropes are used instead of straps they must be adequately tensioned so that a person cannot fall through them and intermediate bands or other means to maintain a constant distance between the ropes must be used.

System of Work to be followed

Holes approximately 1 metre in depth and not more than 20 metres apart should have been predrilled for erecting the strap and pole system close to the face edge and in front of the planned first line of shotholes and also to the side if there is an exposed edge where a person could fall. If these are not pre-drilled the driller must drill these holes before commencing shothole drilling. When the driller alights the drill rig and approaches the quarry face the driller must wear a secured lanyard and harness where the lanyard must not allow the person to reach the quarry face. The harness and lanyard must be used by the driller until such time as the strap and pole system is in place. Care must be taken where there is shattered ground in the area to be drilled for the post holes.

The strap and pole system must be erected by a person(s) who must wear a secured lanyard and harness where the lanyard must not allow the person to reach the quarry face edge.

The strap and pole system must extend beyond either side of the planned front row of holes or where persons will be working and where a person could fall.

The strap and pole system must be adequately tensioned and intermediate bands or other means to maintain a constant distance between the straps must be installed before the person(s) removes their lanyard and harness.

The driller must only drill shotholes within the area of fall protection provided by the straps and poles.

When completing the final row of holes the driller should drill holes to accommodate the poles for any future blast in that area.

When loading the front row of holes at the face the straps and poles must be in front of the first row of shotholes at all points.

Account must be taken of changes in elevation across the blast site to ensure an adequate barrier is in place throughout the working area.

The straps and poles must remain in place until the front row of shotholes have been fully loaded and persons are no longer required to work in front of the first row of shotholes and have been instructed not to pass beyond the front row of shotholes.

The straps and poles should only be removed by a person(s) wearing a secured lanyard and harness where the lanyard must not allow the person to reach the quarry face edge and not be removed where inclement weather or geological conditions such as shattered ground could place persons at risk during removal.

The straps and poles must be removed to a place where they will not be damaged as a result of the blast or by subsequent vehicle movements.

Strap and Pole Edge Protection



Strap and Pole system being erected and tensioned by a person using a harness with inertia reel lanyard



Further information

Health and Safety Authority

Workplace Contact Unit, Metropolitan Building, James Joyce Street, Dublin 1

Telephone: 1890 289 389 Email: wcu@hsa.ie Web: www.hsa.ie



Client and Contractor Code of Conduct at Quarrying Locations

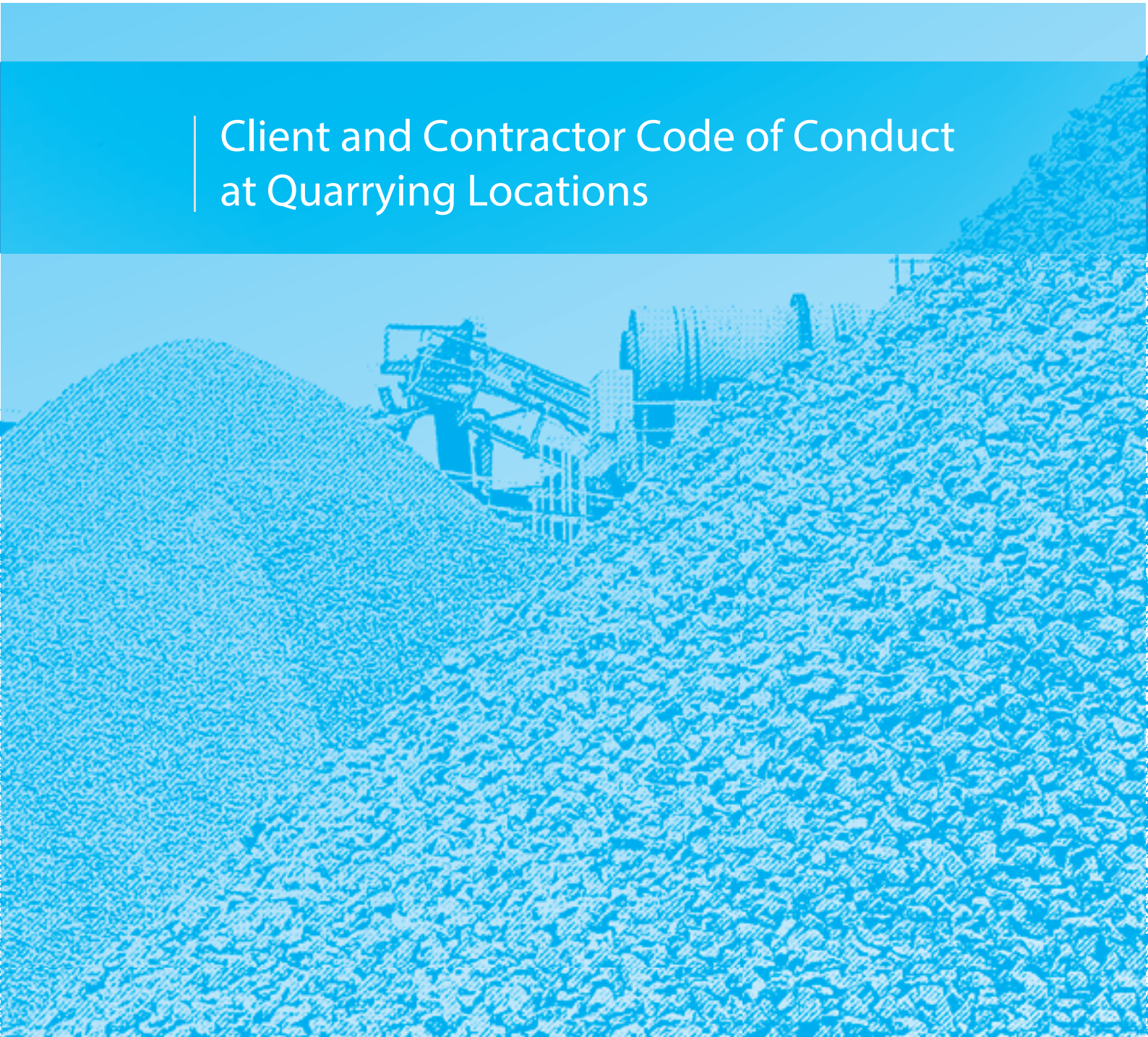

Client and Contractor Code of Conduct at Quarrying Locations

Vision

The client and contractor should focus on the development of mutual respect and a working approach that enables accountability and responsibility without blame that will create an open and challenging environment and enable a drive towards reducing and eliminating incidents and accidents.

Safety, Health and Environment

The client and contractor should communicate and both adhere to an agreed set of standards, regardless of the nature and location of the site and its local standards thereby ensuring that good standards is adopted and adhered to at all times. The Client must provide safe access and egress to and from the contractors place of work within the quarry and that any article or substance provided to the contractor is safe and without risk to health. The contractor must demonstrate that any plant and machinery provided for use within the contract are safe and without risk to health. Both the client and contractor should make relevant parts of their safety statement available to each other.

Inductions

The client should ensure that a site induction of the contractor's employees takes place prior to the commencement of the contracted work that will provide a formal and recorded exchange of relevant information and introduces the contractor's individual employees to the location in order to allow them to carry out the purpose of their activities safely. The site induction should be proportionate to the hazards present, the nature of the task being undertaken and the time taken to complete it.

Point of Contact

The client should appoint a named single point of contact that will act at all times as the location liaison and where possible the contractor should reciprocate by naming their contact on site.

Welfare

The client should ensure that there is access to clean, adequate welfare facilities of a consistent standard for use by contractors whilst at that location.

Engagement

The client and contractor should actively encourage reciprocal involvement in site briefings, toolbox talks and safety committee meetings focusing on partnership and cooperative working that is relevant to the nature of the work undertaken and will ensure active engagement at the location at all levels.

Safety Management Systems & Procedures

The Client and Contractor should expect the principles of good practice relevant to the hazards present to be applied at the location by both parties and by their employees.

Client and Contractor Code of Conduct at Quarrying Locations

Competency

The contractor has a duty to demonstrate to the quarry operator that their employees are competent to carry out activities assigned to them supported by appropriate site based competency checks, some clients may require a 'Contractor's Passport' detailing all training, qualifications and experience necessary to prove competence of their employees prior to commencing work. Where necessary any employees of the contractor must hold and be able to produce when requested by the client any required QSCS certification.

Risk Management

Management systems must be specific to, and reflect the nature of, the activity being undertaken, including a suitable and sufficient approach to risk assessment and implementation of adequate safe systems of work. The emphasis should focus on significant risks and implementation of the related control measures. Any interaction between the activities of the client and those of the contractor must be identified so as to ensure these interactions do not produce additional risks that are not adequately controlled.

Performance Review

The Client and Contractor should carry out routine reviews during and following the completion of works to encourage and enable active learning and improvement. The outcomes of such reviews should be widely communicated.

Incident Investigation

All incident, accident and near-miss investigations should be carried out using a partnership approach embodying the principles laid out in the Safety, Health and Welfare at Work Act, 2005, to ensure immediate, underlying and root causes are identified and addressed, and so that any learning outcomes are circulated and implemented at all of the clients and contractors locations accordingly.



This document was prepared from the QNJAC code of conduct for clients and contractors and the Health and Safety Authority gratefully acknowledge their assistance.

This document is intended to assist both clients and contractors in understanding what they should bring to the relationship and to help bring true partnerships in the client/contractor relationship.

INFORMATION NOTE

INFLATION OF QUARRY VEHICLE TYRES

A recent tyre explosion at a farm in Co. Donegal in 2014 resulting in a double fatality has highlighted the need for quarry operatives to ensure they use safe procedures during the inflation of vehicle tyres. Inflated tyres contain a large amount of stored energy. On typical quarry vehicles the pressure on the tyre sidewall is often in excess of 30 tonnes. Tyres are designed to withstand this but if they are damaged or have been used while flat, or significantly underinflated they may fail. If a tyre fails during inflation the explosive force can be released resulting in a destructive air blast and the ejection of high-speed particles. If the wheel is not restrained, it can fly metres through the air. Similarly, failure of multi-piece (split rim) wheels can result in the explosive ejection of component parts. The rapid release of this explosive force from a ruptured tyre or violent separation of the component parts of the wheel can result in serious injuries, including fatalities.

SAFE TYRE INFLATION

- **DO** use a clip-on chuck to connect the airline with a quick release coupling at the operator's end (this allows tyre deflation from a safe distance if problems occur)
- **DO** ensure the airline hose is long enough to allow the operator to stay outside the likely explosion trajectory during inflation
- **DO** use enough bead lubricant when seating the tyre
- **DON'T** use valve connectors that require the operator to hold them in place
- **DON'T** exceed the manufacturer's recommended tyre pressure for the size and rating of the tyre
- **DON'T** use airlines not fitted with either a pressure gauge or pressure control device
- **DON'T** allow the control valve to be jammed open (which would allow the operator to leave the inflating tyre unattended)

Inform, train and supervise staff in safe personal positioning and safe procedures during tyre inflation including actions when a potential tyre failure is identified

When inflating tyres not mounted on the vehicle always use a restraining device such as a strong, firmly secured tyre inflation cage or a bag type restraint. For very large tyres restraint during tyre inflation will be achieved by mounting the tyre on the wheel hub of the vehicle. Use a protective barrier such as a wall, embankment or the side of another vehicle, to restrain flying objects ejected during failure and ensure that the operator inflates the tyre from a safe position.

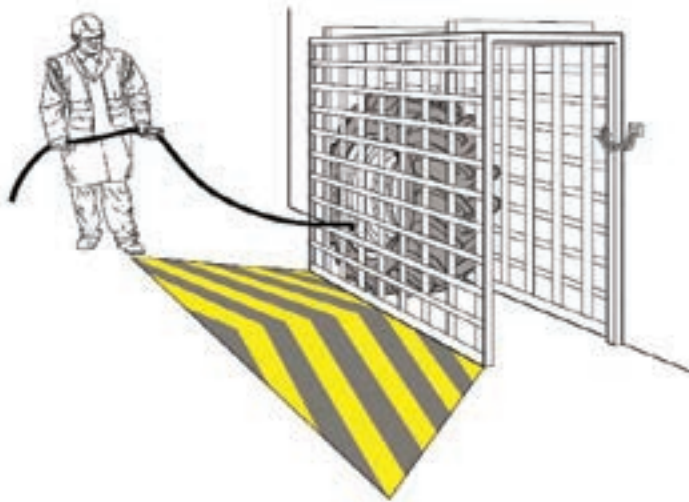

Always stand outside the trajectory of any potential explosion

Need to know more?

For more information on Quarry Health and Safety visit

The HSA Website at http://www.hsa.ie/eng/Your_Industry/Quarrying/ or call 1890 289 389 (ROI) or +353 1 614 7000 (Outside of ROI) or Email: wcu@hsa.ie

The HSENI website at <http://www.hseni.gov.uk/..guidance/industries/mining-and-quarrying.htm> or call 0800 0320 121 or e-mail mail@hseni.gov.uk

For Further Tyre Safety Information visit

<http://tinyurl.com/HSEtyresafety>

<http://tinyurl.com/HSAquarrytyresafety>

<http://tinyurl.com/Tyrecageexplosion> (YouTube Video)

Further Information and Guidance:

Visit our website at www.hsa.ie, telephone our contact centre on **1890 289 389** or email wcu@hsa.ie

Use BeSMART, our free online risk assessment tool at www.besmart.ie

Check out our range of free online courses at www.hsalearning.ie



*Our Vision:
Healthy, safe and
productive lives
and enterprises*

**Health and Safety
Authority**

Tel. 1890 289 389

International
Callers

00353 1 6147000

www.hsa.ie

