



Guidance on regulations for the transport of infectious substances

2023–2024

Applicable as from 1 October 2023

Guidance on regulations for the transport of infectious substances

2023–2024

Applicable as from 1 October 2023

Guidance on regulations for the transport of infectious substances, 2023–2024

ISBN 978-92-4-008952-5 (electronic version)

ISBN 978-92-4-008953-2 (print version)

© World Health Organization 2024

Some rights reserved. This work is available under the Creative Commons Attribution-NonCommercial-ShareAlike 3.0 IGO licence (CC BY-NC-SA 3.0 IGO; <https://creativecommons.org/licenses/by-nc-sa/3.0/igo>).

Under the terms of this licence, you may copy, redistribute and adapt the work for non-commercial purposes, provided the work is appropriately cited, as indicated below. In any use of this work, there should be no suggestion that WHO endorses any specific organization, products or services. The use of WHO logo is not permitted. If you adapt the work, then you must license your work under the same or equivalent Creative Commons licence. If you create a translation of this work, you should add the following disclaimer along with the suggested citation: “This translation was not created by the World Health Organization (WHO). WHO is not responsible for the content or accuracy of this translation. The original English edition shall be the binding and authentic edition”.

Any mediation relating to disputes arising under the licence shall be conducted in accordance with the mediation rules of the World Intellectual Property Organization (<http://www.wipo.int/amc/en/mediation/rules/>).

Suggested citation. Guidance on regulations for the transport of infectious substances, 2023–2024. Geneva: World Health Organization; 2024. Licence: [CC BY-NC-SA 3.0 IGO](https://creativecommons.org/licenses/by-nc-sa/3.0/igo).

Cataloguing-in-Publication (CIP) data. CIP data are available at <http://apps.who.int/iris>.

Sales, rights and licensing. To purchase WHO publications, see <http://apps.who.int/bookorders>. To submit requests for commercial use and queries on rights and licensing, see <http://www.who.int/about/licensing>.

Third-party materials. If you wish to reuse material from this work that is attributed to a third party, such as tables, figures or images, it is your responsibility to determine whether permission is needed for that reuse and to obtain permission from the copyright holder. The risk of claims resulting from infringement of any third-party-owned component in the work rests solely with the user.

General disclaimers. The designations employed and the presentation of the material in this publication do not imply the expression of any opinion whatsoever on the part of WHO concerning the legal status of any country, territory, city or area or of its authorities, or concerning the delimitation of its frontiers or boundaries. Dotted and dashed lines on maps represent approximate border lines for which there may not yet be full agreement.

The mention of specific companies or of certain manufacturers' products does not imply that they are endorsed or recommended by WHO in preference to others of a similar nature that are not mentioned. Errors and omissions excepted, the names of proprietary products are distinguished by initial capital letters.

All reasonable precautions have been taken by WHO to verify the information contained in this publication. However, the published material is being distributed without warranty of any kind, either expressed or implied. The responsibility for the interpretation and use of the material lies with the reader. In no event shall WHO be liable for damages arising from its use.

Photo credits: front cover (from left to right) ©WHO/Zakarya Safari, ©WHO/Roni Ziadeh, ©WHO.

Contents



Foreword	iv
Acknowledgements	iv
Section 1. Transport regulations	1
1.1 International regulations and guidelines	1
1.2 Modal agreements	2
1.3 Regional and subregional regulations	3
1.4 National regulations	3
1.5 Operator/carrier variations	4
1.6 Special provisions	5
1.7 Dangerous goods security	5
1.8 Customs and border control	5
Section 2. Transport stakeholders	8
2.1 The shipper	8
2.2 The packaging supplier	9
2.3 The operator/carrier	9
2.4 The receiver	9
2.5 General points to note	10
Section 3. Training	11
Section 4. Defining a material for transport	13
4.1 Cultures	13
4.2 Patient specimens	14
4.3 Biological products	14
4.4 Medical or clinical wastes	14
4.5 Medical devices or equipment	15
4.6 Exceptions	15
Section 5. Classification of infectious substances	17
5.1 Dangerous goods classes and divisions	17
5.2 Infectious substance categories	18
Section 6. Preparing packaging requirements	21
6.1 A basic triple packaging system	22
6.2 Packing instruction P650 (Category B infectious substance requirements)	23
6.3 Packing instruction P620 (Category A packaging requirements)	24
6.4 Packing instruction P621 (medical or clinical waste requirements)	27
6.5 Packing with coolants	27
6.6 Packing with stabilizers	29
6.7 Packing in overpacks	29
6.8 Re-cycling packaging	29
Section 7. Marking and labelling	31
7.1 Marks	31
7.2 Labels	32
Section 8. Documenting shipments	35
8.1 Dangerous Goods Transport Document (DGTD)	35
8.2 Air waybill	38
8.3 Contractual arrangements between shipper and receiver	39
Section 9. Incidents and accidents	41
9.1 Spill clean-up procedure	41
9.2 Reporting of accidents and incidents	42
9.3 Legal and compliance	42
References	43
Annex 1: International regulations and modal agreements	44
Annex 2: Special provisions	46
Annex 3: Indicative list of infectious substances sub-classified as Category A	49
Annex 4: Packing Instructions	51
A4.1 Packing Instruction P620	51
A4.2 Packing Instruction P650	53
A4.3 Packing Instruction P621	54
A4.4 Packing Instruction PI954	55
Annex 5: Additional regulations affecting the import and export of infectious substances	56
A5.1 Relevant regulations for export	56
A5.2 Relevant regulations for import	57

Foreword

This publication offers practical guidance to facilitate compliance with applicable international regulations for the transport of infectious substances by all modes of transport and includes the changes that apply from 1 October 2023. Existing national and international regulatory frameworks for the transport of infectious substances are included to provide information for classifying, identifying, packaging, marking, labelling, documenting and refrigerating infectious substances for transportation and ensuring their safe delivery.

The information in this publication targets all stakeholders involved in the shipping of infectious substances, such as the shipper, packaging supplier, operator/carrier and receiver.

The 2023–2024 edition of this document went through several World Health Organization (WHO) internal review/clearance processes.

The content of this document is connected to diverse activities conducted by WHO and other organizations, ranging from biosafety/biosecurity trainings and WHO Infectious Substances Shipping Training (ISST)¹ to any other programmes that require off-site transport of infectious substances for further processing, storage or disposal.

The biannual update of this document reflects the changes in the source documents. The current revision replaces the document issued by WHO in 2021, including the electronic version (ISBN: 9789240019720) and print version (ISBN: 9789240019737). When using this publication, reference must be made to the applicable national and international regulations.

Acknowledgements

WHO would like to acknowledge the technical contribution to this guidance made by Lisa Stevens (WHO), Rica Zinsky (WHO) and Markus Huber (WHO).

The production and technical editing of the Guidance on regulations for the transport of infectious substances 2023–2024 was led by Kazunobu Kojima (WHO).

WHO appreciates the contributions and inputs to the draft guidance by Monika Gsell Albert (University of Bern, Infectious Disease Institute) and Katherine Rooney (International Civil Aviation Organization).

1 Note: this course has limited eligibility.

SECTION 1.

Transport regulations

1.1 International regulations and guidelines

Work with biological agents, including diagnostic activities, biomedical research and pharmaceutical manufacturing, plays a key role in the detection and prevention of outbreaks of emerging and highly infectious disease and reduction of other risks to international health security. Facilities handling biological agents have a responsibility to ensure that biological agents are identified, safely stored, and controlled in adequately equipped facilities according to best practices.

While materials containing biological agents are being transported, there exists a likelihood of exposure to people and the environment. To appropriately control and reduce this risk, various international groups have developed recommendations and/or regulations that outline the way in which infectious substances should be packaged, marked, labelled and documented, to ensure safety and containment throughout the transport process.

UN Model Regulations

One of the most widely known and referenced set of recommendations are the *Recommendations on the Transport of Dangerous Goods–Model Regulations (23rd revised edition) (1)* (hereinafter referred to as the *UN Model Regulations*). These recommendations are made by the Committee of Experts on the Transport of Dangerous Goods (UNCETDG), a committee of the United Nations Economic and Social Council, comprising expert advisors from various countries, non-governmental organizations and specialized agencies including World Health Organization (WHO) representatives. The recommendations are continuously reviewed in two-year cycles and updated by the committee in light of technical progress, the introduction of new substances or materials, modern pressures on transport systems, and emerging safety requirements for people, property and the environment.

The *UN Model Regulations* aim to provide a minimum set of provisions to safely transport any dangerous goods, which includes infectious substances. The use of this same set of provisions as a basis across various national and international regulations aims to introduce conformity and harmonization across them all. However, the *UN Model Regulations* provide a certain degree of flexibility, so that the basics may still be adapted to fit local needs and special requirements for overcoming barriers in transport. Adapted versions may then be adopted by governments and/or international organizations as mandatory or legally binding regulations for the transport of dangerous goods.

The subsequent implementation of, and compliance with, adopted regulations may be overseen by independent bodies or national authorities, as designated by the relevant governing body. There are several other international regulations, guidelines and documents that may play a key role in the international transport of infectious substances. In international regulation, it is crucial to understand

that applicability for specific regulations or obligations often applies not only when your country and the recipient country or any transit country are signatory to an agreement, but may apply, as well, if only one country is a signatory. Failure to consider the status of all countries involved can lead to a substantial delay or blocking of a shipment. It is important to understand that, depending on the specificity and origin of the material at hand, multiple international regulations may apply, which can substantially complexify the shipping process. Always consult current, specific regulatory and guideline documents applicable in the relevant jurisdictions when dealing with the shipment of potentially hazardous biological materials.

International regulations pertaining to the international transport of infectious substances are outlined in Annex 1: International regulations & modal agreements.

1.2 Modal agreements

While the *UN Model Regulations* are general enough to cover all modes of transport, they are most commonly reflected in international law through international modal agreements, which adapt and publish guidelines or regulations specialized for a specific mode of transport. Some of the most common modal agreements for the transport of dangerous goods are described in Table 1. References and online links to these agreements may also be found in Annex 1 of this document.

Table 1: A summary of the modal agreements containing relevant dangerous good regulations

Mode of transport	International modal agreements
Air	<p>The <i>Technical Instructions for the Safe Transport of Dangerous Goods by Air (2)</i> (hereinafter referred to as the <i>ICAO Technical Instructions</i>) are a detailed set of instructions deemed necessary for the safe international transport of dangerous goods by air. Published by the International Civil Aviation Organization (ICAO), these legally binding international regulations apply on all international flights. They are regularly reviewed and updated based on comments received from states and interested international organizations, including WHO, or based on recommendations of the UNCETDG or the International Atomic Energy Agency (IAEA).</p> <p>The International Air Transport Association (IATA) also publishes <i>Dangerous Goods Regulations (DGR) (3)</i> that incorporate the ICAO provisions and may add further restrictions stemming from operational considerations. The DGR also present state and operator variations. IATA DGR are applicable to its member and some other airlines as well as all shippers and agents that offer consignments of dangerous goods to these operators.</p> <p>For national flights (i.e. flights within one country), national civil aviation authorities may apply national legislation. This is normally based on the ICAO provisions but may incorporate variations. State and operator variations are published in both the <i>ICAO Technical Instructions</i> and in the IATA DGR.</p>
Rail	<p>A set of regulations concerning the <i>International Carriage of Dangerous Goods by Rail (RID) (4)</i> has been created by the Intergovernmental Organisation for international Carriage by Rail (OTIF) and applies to countries in Europe, the Middle East and North Africa. RID also applies to domestic transport in the European Union through Council Directive 2008/68/EC (5).</p>

Road	The <i>Agreement concerning the International Carriage of Dangerous Goods by Road (ADR) (6)</i> applies to signatory countries. In addition, modified versions of this agreement are being used by countries in South America and South-East Asia. ADR also applies to domestic transport in the European Union through Council Directive 2008/68/EC.
Sea	The <i>International Maritime Dangerous Goods Code (7)</i> published by the International Maritime Organization (IMO) requires mandatory application for all contracting parties to the International Convention for the Safety of Life at Sea (SOLAS).
Post	<p>The <i>Letter Post Manual</i> published by the Universal Postal Union (UPU) reflects the <i>UN Model Regulations</i> by using the <i>ICAO Technical Instructions</i> as the basis for shipments.</p> <p>It should be noted that some infectious substances considered to be of a high-risk category (known as “Category A Infectious Substances”) will not be accepted for shipment through postal services. Some infectious substances in lower risk categories (such as “Biological Substance, Category B – UN3373” or “Patient specimens”) may be shipped by registered air mail. For more information on infectious substances categories, please refer to Section 5.2.</p> <p>Local/international restrictions may also be in force. Prior contact should therefore be made with the national public operators for registered mail to ascertain whether the packaged material will be accepted by the postal service in question.</p>

1.3 Regional and subregional regulations

Regional or subregional regulations are in place to oversee specific agreed-upon elements. For example, the European Union (EU) has stringent guidelines on the management and transport of animal by-products (Regulation (EC) No 1069/2009) and animal pathogens (Regulation (EU) 2016/429), which include materials not intended for human consumption, such as animal waste or carcasses, to minimize the risk of transmitting infectious diseases. These subregional regulations set standards for how these materials should be handled and transported to prevent the spread of disease.

An additional example involves the utilization of so-called Hazchem labelling across South-East Asian nations and by Australia. This standardized labelling system serves as a crucial method for communicating hazardous chemical information, ensuring consistent understanding and handling of potentially dangerous substances across these regions.

1.4 National regulations

Many countries adopt the *UN Model Regulations* or its modal agreements in their entirety to stand as their national dangerous goods legislation, while others apply variations that suit local conditions and requirements. National authorities should be able to provide details of their own national requirements to relevant users.

Where national regulations do not exist, the international modal agreements described above should be followed. Should multiple regulations apply to a single shipment of infectious substances, the most stringent ones should be applied. Please find an example of such a national regulation in Fig. 1.

Fig. 1. An example of a national variation requirement, taken from the ICAO Technical Instructions

VU — VANUATU		
VU 1	The marking of packages and overpacks and the Dangerous Goods Transport Document accompanying dangerous goods consignments must be in English or French. If the State of Origin requires another language each shall be given equal prominence.	5;2.5 5;4.1.6.3
VU 2	Infectious substances are prohibited from entry to Vanuatu without prior approval from the Vanuatu Government Department of Health. Requests for approval should be addressed to: Director of Health P.O. Box 102, Port-Vila Vanuatu	1;1.2

1.5 Operator/carrier variations

The transport of infectious substances is of international concern due to the public health impact/effects and needs. Much of the transport/logistics chain, however, is not a public health service, and also includes industries of a commercial nature. In many cases, safety and security is a key factor not only for health concerns, but also for reasons of reputability and trust. For this reason, although modal agreements and national regulations exist to appropriately address safety procedures, companies operating commercial enterprises (e.g. airlines or couriers) may enforce additional safety requirements for shipments in their carriage, aiming to achieve a high level of accountability for their clients.

Although not usually legally binding, failure to comply with such variations may result in a refusal of service between that enterprise and the person trying to send the infectious substances. Failure to comply with operator/carrier variations is generally the most common reason for delayed or refused shipments. Furthermore, a commercial enterprise that does not wish to carry particular dangerous goods is under no legal obligation to do so, even if compliance with applicable regulations is met.

ICAO and IATA list the main operator/carrier restrictions in force among airlines. Some airlines will not carry dangerous goods at all, while others will carry only a very limited range of goods. An example of one such restriction can be seen in Fig. 2. As carrier restrictions for the different modes of transport are not published centrally, harmonization between stakeholders is essential.

Fig. 2. An example of an operator/carrier variation, as seen in the IATA Dangerous Goods Regulations

BZ (Blue Dart Aviation Ltd.)
...
BZ-07 Dangerous goods listed in the List of High-Consequence dangerous goods will not be accepted for carriage. However, dangerous goods of Division 6.2, infectious substances in category A (UN 2814 and UN 2900) and substances of Division 6.1 in Packing Group I will be accepted subject to prior approval by Blue Dart.
...

1.6 Special provisions

“Special provisions” is a term used to describe certain circumstances or procedures that are not covered in standard regulations. These provisions are therefore needed to supplement or modify the original regulations to appropriately ship the dangerous good to which it applies.

Tables listing special provisions applicable to dangerous goods may be found in most international regulation documents, including the *UN Model Regulations*. A short list of special provisions that may be applicable to infectious substance shipments is also provided in Annex 2 of this document.

1.7 Dangerous goods security

High-consequence dangerous goods, often referred to as dual-use or strategic goods, are those which have the potential for misuse in a terrorist event and which may, as a result, produce serious consequences, such as mass casualties or mass destruction. Division 6.2 infectious substances of Category A (UN 2814 and UN 2900) and medical waste of Category A (UN 3549) described in the *UN Model Regulations* are considered high-consequence dangerous goods. There are several other lists (e.g. the Australia Group - Common Control Lists) relevant to the transport of infectious substances and associated materials, which countries have adopted and are legally binding.

Shippers, operators and others, including infrastructure managers, engaged in the transport of high-consequence dangerous goods should adopt, implement and comply with a security plan. As a minimum, the security plan should consist of the following elements:

- a specific allocation of responsibilities for security to competent and qualified persons with appropriate authority to carry out their responsibilities;
- records of dangerous goods or types of dangerous goods transported;
- a review of current operations and an assessment of vulnerabilities, including inter-modal transfer, temporary transit storage, handling and distribution as appropriate;
- a clear statement of measures, including training policies (e.g. response to higher threat conditions, and new employee/employment verifications), operating practices (e.g. access to dangerous goods in temporary storage, which is near to vulnerable infrastructure), and equipment and resources that are to be used to reduce security risks;
- effective and up-to-date procedures for reporting and dealing with security threats, breaches of security or security incidents;
- procedures for the evaluation and testing of security plans and procedures for periodic review and update of the plans;
- measures to ensure the security of transport information contained in the plan; and
- measures to ensure that the distribution of the transport information is limited as far as possible (such measures shall not preclude provision of transport documentation).

Specific requirements and processes for the safe and secure transport of such high-consequence materials are specified in the respective jurisdiction of each country or region.

1.8 Customs and border control

Customs and border control agencies play a critical role in regulating the import and export of infectious substances to safeguard public health, often requiring specialized documentation, packaging, and handling procedures to minimize the risk of disease transmission across borders. The

export and import regulations and procedures noted below, while not exhaustive, point out important rules that may be crucial for shipping. It is important to plan enough time for obtaining the necessary permits and licenses for a successful shipment across borders. Some customs services require prior information before the actual shipment takes place. When shipping across borders, there might be customs duties, import/export taxes, and handling charges imposed by both the originating and destination countries' authorities.

Due diligence should be exercised, ensuring that both the exporting and importing countries' requirements are met and all requisite permissions and permits are obtained, as well as that the end user is legitimate and credible. Failure to adhere to these regulations can result in penalties or blocking of the shipment.

1.8.1 HS-code and HTS-code

In the complex landscape of international shipping, Harmonized System (HS) codes serve as a universal language for categorizing goods, ensuring a streamlined customs process. For stakeholders involved in the shipment of infectious substances, understanding and accurately using these codes is crucial. HS codes help customs officials to quickly identify the nature of the goods, their potential risks, and the need for special handling or regulations. Specifically, when shipping infectious substances, the correct HS code ensures that these sensitive materials are handled in compliance with international safety standards, mitigating risks to public health and the environment.

Harmonized Tariff Schedule (HTS) codes are a system of numeric codes used by countries to classify traded goods for customs purposes. Developed on the basis of the Harmonized System (HS), HTS codes extend the six-digit HS code with additional digits for more specific categorization. These codes are crucial for determining import duties and for gathering statistical data on international trade. Each country has its own version of the HTS, tailoring it to its own tariff and trade requirements, resulting in country-specific codes that detail the tariffs and regulations applied to imported goods.

1.8.1.1. HS code (Harmonized System code)

- It was developed by the World Customs Organization (WCO).
- Its purpose is as an international standard for categorizing goods in international trade. It is a six-digit code used universally.
- Its scope is to provide a basis for customs tariffs and for the compilation of international trade statistics. The first six digits are the same in all countries that have adopted the HS code system.
- An example is 3002.90, Human Blood; Animal Blood, prepared for therapeutic, prophylactic, or diagnostic uses; Toxins, Cultures of Micro-organisms (excluding yeasts) and Similar Products.

1.8.1.2. HTS code (Harmonized Tariff Schedule code)

- It was developed by Individual countries, based on the HS Code system.
- Its purpose is use by a specific country (such as the United States of America) for its own customs and duties. It extends the six-digit HS code to further classify goods for tariff and statistical purposes.
- Its scope is more specific than the HS code, often containing 7 to 10 digits. The additional digits allow each country to customize the code to meet its own particular needs.
- An example is 3002.90.52.50, Human Blood; Animal Blood, prepared for therapeutic, prophylactic, or diagnostic uses; Toxins, Cultures of Micro-organisms (excluding yeasts) and Similar Products (in the U.S. HTS system).

1.8.2 Export permits and licenses

Export licenses are required for shipping infectious substances and associated material to ensure compliance with international and domestic safety regulations, thereby minimizing the risk of accidental release or misuse that could pose a threat to public health or security. The granting of this license or permit is typically accompanied by additional requisite documentation. Collectively, these serve as the final authorization required for the given activity or operation.

Please find other relevant regulations, such as the Convention on International Trade in Endangered Species of Wild Fauna and Flora (CITES), Nagoya Protocol, Cartagena Protocol, and Basel Convention on the Control of Transboundary Movements of Hazardous Wastes for exporting infectious substances in Annex 5.

Dual-use and strategic goods

The concept of dual-use refers to items, including infectious substances and related materials, that have both civilian and potential military applications, such as biological research that could be misused for creating biological weapons. The transportation of such materials is therefore subject to strict regulations to prevent misuse or unauthorized access.

For exporting infectious substances that are potentially dual-use or strategic goods, you usually must obtain an export license from the appropriate government authority. This involves submitting detailed information about the substance, its intended use, and the receiving entity, among other requirements. Due diligence in end-user verification and compliance with both domestic and international regulations is critical in this process to minimize security risks. Governments typically disseminate lists detailing goods, technologies, and software that are subject to restrictions. These lists may be implemented at a national or regional/subregional level.

1.8.3 Import permits and licenses

The import of infectious substances involves a regulated and stringent process to ensure public safety and environmental protection. Compliance with both international and national regulations is essential. Agencies may require importers to obtain special permits, which include biosafety approvals, transport authorizations, and customs clearances. The permits ensure that the infectious materials are appropriately contained, transported, and handled to minimize risks. Given the sensitive nature of such substances, failing to obtain the necessary licenses can result in legal repercussions, as well as potential health and safety hazards. Therefore, it is crucial to gather all necessary licenses and approvals before initiating the import process.

Import license or permit

Certain jurisdictions necessitate the acquisition of specific import licenses or permits for bringing infectious substances and related materials into the country. This requirement aims to ensure alignment with both international and domestic safety regulations, thereby mitigating the risk of inadvertent release or misuse that could jeopardize public health or security. Additionally, it must be ensured that the recipient is both capable and qualified to receive the material in question. The issuance of such licenses or permits is usually accompanied by supplementary documentation essential for regulatory compliance. Together, these documents constitute the ultimate authorization mandated for the designated activity or process.

Please find other relevant regulations, such as Dual-use and strategic goods regulation, CITES, Nagoya Protocol, Cartagena Protocol, Basel Convention on the Control of Transboundary Movements of Hazardous Wastes, and notifications and registration requirements for importing infectious substances in Annex 5.



SECTION 2.

Transport stakeholders

From the time an infectious substance is packed until it reaches its destination, many different stakeholders may have participated in the transport process. The efficient transfer of infectious substances requires good coordination and harmonization between all parties involved in the shipment. This includes the person or institution sending the substance, the commercial entities involved in carrying the package, and the person or institution receiving the substance.

An overview of the responsibilities of the primary stakeholders involved in the transport process are provided below.

2.1 The shipper

The shipper:

- may also be known as the consignor or the sender;
- ensures the correct identification, classification, packaging, marking, labelling, and documentation of all infectious substances destined for transport;
- ensures that packaging selected is suitable and compliant for the substances being shipped;
- confirms with the national authorities that the material may be legally exported;
- makes itself aware of all regulations applicable to its shipment, based on the place or origin, transit, destination and/or mode of transport;
- explores whether additional approvals are required, such as export/import permits;
- makes primary contact with the receiver of the package to ensure they are capable, competent, authorized and prepared to receive the shipment;
- ensures that the package is prepared in accordance with the instructions from the package manufacturer;
- makes advance arrangements with the carrier to ensure:
 - there are no additional operator variations applicable to the shipment
 - the shipment will be accepted for appropriate transport
 - the shipment is undertaken by the most direct routing (direct transport if possible);
- prepares necessary documentation, including permits and dispatch and shipping documents, retaining a copy of each; and
- notifies the receiver of transportation arrangements once these have been made, well in advance of the expected arrival time.

2.2 The packaging supplier

The packaging supplier:

- manufactures and tests lines of packaging materials according to applicable regulations;
- makes available test reports and results on request to users of their packages, and/or national competent authorities;
- provides instructions to users regarding the procedures to be followed, and additional components needed, to ensure their packaging materials are capable of meeting performance requirements; and
- if required, is registered with a quality assurance programme as directed by national competent authorities.

2.3 The operator/carrier

The operator/carrier:

- may include logisticians, courier companies, airline freight forwarders or other transport operators;
- may provide advice to the sender regarding the necessary shipping documents and instructions for their completion;
- may provide advice to the sender about correct packaging;
- assists the sender in arranging the most direct routing and then confirms the routing; and
- maintains and archives copies of the documentation for shipment and transport.

Note: *The shipper is responsible for ensuring the package and documentation is prepared in compliance with the regulations, on top of any advice received from the carrier.*

2.4 The receiver

The receiver:

- may also be known as the consignee, importer, or buyer;
- confirms with the national authorities that the substance may be legally imported and registered;
- obtains the necessary authorization(s) from national authorities for the receipt of the substance, such as importation permits, which may need to be provided to the sender, as applicable;
- arranges for the most timely and efficient collection on arrival; and
- acknowledges receipt to the sender.

Consignor: The person or organization responsible for sending the shipment, also known as the shipper or sender.

Consignee: The person or organization responsible for receipt of the shipment, which may also be known as the receiver or buyer.

Consignment: A package, or group of packages (shipment), destined for delivery.

2.5 General points to note

General points to note are that:

- both shippers and carriers must adhere to all relevant laws and regulations;
- specific responsibilities might be outlined in a contract material transfer agreement (MTA) or shipping agreement, and these can vary significantly depending on the arrangement between the involved parties;
- often, carriers have limitations on their liability, especially in cases where damage or loss is not due to their negligence;
- insurance is often utilized to manage risks associated with shipment content, damage, and loss; and
- crucially, specific responsibilities might vary depending on the region, type of goods being shipped, and specific arrangements between parties involved. Always refer to relevant local laws, international shipping regulations, and specific contract terms to determine precise responsibilities in a shipping scenario.

SECTION 3.

Training

Before a consignment of dangerous goods is offered for transport, all relevant persons involved in its preparation must have received training to enable them to carry out their responsibilities. Where the organization responsible for preparing the shipment does not have appropriately trained staff, the “relevant persons” may be interpreted as those contracted to act on the shipper’s behalf and undertake the shipper’s responsibilities in the preparation of the shipment. However, such persons must still be able to fulfil applicable training requirements.

Personnel should be trained in a manner which corresponds to their contractual responsibilities. Therefore, the content of the training provided should be determined by analysing their assigned roles and responsibilities as part of their job description. In some cases, this should be determined by the employer but in others it will be stipulated and/or governed by national competent authorities. Employees should only ever carry out functions for which the required training has been provided OR be appropriately supervised and signed off by another competent individual.

According to the *UN Model Regulations*, all individuals involved in the transport of dangerous goods shall be trained in the contents of dangerous goods requirements commensurate with their responsibilities, which should include the following areas.

1. **General awareness and familiarization training.** This should involve familiarization with the general provisions of dangerous goods transport requirements, including:
 - a. description of the classes of dangerous goods
 - b. labelling, marking and placarding
 - c. packaging

There are a wide range of stakeholders who must be trained appropriately for the safe and compliant shipment of infectious substances including:

- the persons or organizations undertaking the responsibilities of the shipper;
- staff of transport operators (e.g. drivers, pilots, captains);
- ground handling agencies, which perform, on behalf of the operators/carriers, the accepting, handling, loading, and unloading of dangerous goods packages;
- individuals involved in the transferring, processing or screening of cargo or mail, such as security staff:
- freight forwarders; and
- designated postal operators.

The **ICAO Technical Instructions** provide a more detailed overview of the various aspects of dangerous goods transport that various types of personnel should be familiar with to be considered competent to ship dangerous goods.

-
- d. segregation
 - e. compatibility of dangerous goods
 - f. purpose and content of dangerous goods documentation
 - g. descriptions of available emergency response documents.
2. **Function-specific training.** Personnel must be competent to perform any functions for which they are responsible prior to performing any of these functions. For example, a shipper of a public health institution may need to be trained on the details of classification, packing, labelling, marking and documenting dangerous goods, while a carrier may require more training on acceptance, handling, loading, stowing and logistics procedures. Function-specific competencies should be appropriately supervised until competency is assured, which may require the completion of approved training courses and/or passing examinations, and for on-the-job assessment.
3. **Safety training.** This includes:
- a. methods and procedures for avoiding accidents (e.g. proper use of package handling equipment and appropriate methods for the stowage of dangerous goods);
 - b. emergency response information and how to use it;
 - c. general dangers and hazards of the various dangerous goods classes;
 - d. prevention of exposure to hazards, including the use of personal protective equipment
 - e. procedures to be followed in the event of an unintentional release of, spilling of or exposure to any dangerous goods; and
 - f. conducting a thorough risk assessment for the whole shipment.

It should be noted that most modal agreements include provisions that require the testing and verification of an individual's knowledge and competency in the aforementioned areas for any person involved in dangerous goods transportation. For example, the *UN Model Regulations* stipulate that anyone involved in the shipment of high-consequence dangerous goods, which includes division 6.2 infectious substances of Category A (UN2814 and UN2900) and medical waste of Category A (UN3549), must undertake appropriate training and provide training records on request.

Records of training conducted should be kept by the employer. The employer should be able to make these records available on request by the employee or a national competent authority, as they may need to be verified upon new appointment or the acquisition of new responsibilities. Training should be periodically supplemented with retraining, as deemed necessary by the competent authority. Typically, training and competency testing should be repeated at least every two years (24 months) but may vary for different modes of transport. Dangerous goods training programmes may be subject to review and approval by the relevant national competent authorities.

For comprehensive technical guidance on the safe and compliant shipping of infectious substances, eligible stakeholders can take the World Health Organization's digital Infectious Substances Shipping Training (e-ISST) and e-ISST refresher course (please see eligibility criteria for enrolment to the course on the webpage). This training program provides an overview of international and domestic regulations, packaging requirements, and best practices to ensure the safe transportation of infectious substances. WHO e-ISST and refresher e-ISST serves as an invaluable resource for professionals involved in the shipping, handling, and receiving of infectious materials, offering theoretical insights to mitigate risks to public health and safety. For more information, please visit the World Health Organization's Health Security Learning platform webpage¹.

1 Health Security Learning Platform. Geneva: World Health Organization (WHO Emergency Preparedness Division) (<https://extranet.who.int/hslp/training/course/search.php?search=cours&perpage=10&page=1>).



SECTION 4.

Defining a material for transport

For the purpose of transport, materials or products, which are known to contain, or are reasonably expected to contain, biological agents that cause disease in humans or animals (i.e. pathogens), are known as infectious substances. Pathogens are defined as microorganisms (including bacteria, viruses, parasites, fungi) and other agents, such as prions, which can cause disease in humans or animals. In this context, the terms infectious substances, infectious materials or infectious products are considered to be synonymous.

Before beginning the transportation process, it is important to define what is being shipped and whether this is, in fact, an infectious substance. Provided below are several products which may fall under the definition of infectious substances, under certain circumstances. A classification system outlined in Section 5 supports the shipper in deciding which UN number and proper shipping name will be assigned to which substance. This UN number and the proper shipping name will be used in all aspects of the package preparation, including its packaging composition, marking, and labelling, and for documentation purposes.

4.1 Cultures

Culture is a method by which biological agents are intentionally propagated, under controlled laboratory conditions, inside a designated medium or in animals. This results in a concentrated collection of cultivated biological agents known as cultures, which may be used in research or diagnostics or stored in culture collections. Any cultured biological agent capable of causing disease in humans or animals will fall under the definition of infectious substances.

Infected live animals:

Live animals (including those which have been genetically modified), which have been infected with an infectious substance, must be transported in accordance with appropriate regulations in the live animals' country of origin, transit and/or destination. Such regulations are usually associated with proper animal care, and as such, infectious substances transport regulations will not generally be applicable. Live animals must NOT be used as a means to transport infectious substances unless such substances cannot be consigned by any other means.

A live animal that has been intentionally infected and is known or suspected to contain an infectious substance may only be transported by air under terms and conditions approved by the appropriate national authority of the states of origin, transit, destination and operator.

4.2 Patient specimens

Products or materials that are collected directly from humans or animals for the purpose of research and/or diagnostic investigations are known as patient specimens. These may be referred to as patient samples, diagnostic specimens, or diagnostic samples. This includes, but is not limited to, body fluids (i.e. excreta, secreta, blood/blood products), tissues or body parts collected in containers, on swabs, or submerged in preservative medias. As with cultures, if the patient specimen contains biological agents capable of causing disease in humans or animals, they will be defined as infectious substances.

4.3 Biological products

Substances or materials that are derived from living organisms (e.g. bacteria, fungi, vaccines, animals, humans) and are extracted and/or purified for use as a preventative, therapeutic or diagnostic tool are known as biological products. This may include, but is not limited to, antitoxins, vaccines or vaccine components. It is important to note that, due to their importance in disease treatment and prevention, some biological products may be governed by special requirements or licensing agreements set out by national authorities. In this case, their manufacture and distribution could be subject to regulations that differ from, or be in addition to, those set out for infectious substances.

4.4 Medical or clinical wastes

In treating patients (humans or animals) and conducting laboratory activities, consumables are used, and waste is generated that is contaminated by reagents, liquids, tissues, cultures and other products. If this waste contains biological agents, capable of causing disease in humans or animals, then this medical or clinical waste is an infectious substance.

The following refers to medical or clinical wastes containing infectious substances.

- Category A infectious substances must be assigned to UN 2814, UN 2900, or UN 3549, as appropriate and stated in the *UN Model Regulations*. Solid medical waste containing Category A infectious substances generated from the medical treatment of humans or veterinary treatment of animals may be assigned to UN 3549. The UN 3549 entry must not be used for waste from bioresearch or liquid waste.
- Category B infectious substances must be assigned to UN 3291.

Medical or clinical wastes which are reasonably believed to have a low probability of containing infectious substances must be assigned to UN 3291. For the assignment, international, regional, or national waste catalogues may be taken into account.

“n.o.s.” is an abbreviation meaning “not otherwise specified”. Other proper shipping names for medical or clinical wastes may be applicable to shipments for other modes of transport. Applicable regulations should be consulted to establish the correct proper shipping name to use.

This is not the same as “Nos.”, which is an abbreviation meaning “Numbers” (e.g. UN Nos. 2814, 3291, 2900) often used in the UN Model Regulations for stating more than one UN number.

Note: The proper shipping name for UN 3291 is *Biomedical waste, n.o.s.; Clinical waste, unspecified, n.o.s.; Medical waste, n.o.s.; or Regulated medical waste, n.o.s.*

Decontaminated medical or clinical wastes which previously contained infectious substances are not subject to the *UN Model Regulations* unless they meet the criteria for inclusion in another class of dangerous goods.

4.5 Medical devices or equipment

Similar to medical or clinical wastes, medical devices or equipment, which have been contaminated by biological agent during patient treatment or laboratory processes, may be defined as infectious substances if the biological agents contained within them are capable of causing disease in humans or animals.

Note: Genetically modified organisms (GMOs) or microorganisms (GMMOs) are animals, plants, biological agents, or cellular materials, which have been subject to a genetic modification, which is different from their natural state.

GMOs and GMMOs, which do not meet the definition of toxic or infectious substances, must be assigned to UN 3245.

COVID-19 vaccines containing GMOs or GMMOs, including those in clinical trials, are not subject to the *Dangerous Goods Regulations*.

For an introduction to UN numbers and other dangerous goods classes, consult the section below on classification. For more detailed information on non-infectious GMOs/GMMOS, please consult the *UN Model Regulations*.

4.6 Exceptions

There are some circumstances where, although the material or product being shipped falls under one of the definitions above, it will not meet the definition for an infectious substance due to the confirmed absence of biological agents, or because any biological agents present are known to be incapable of causing disease in humans or animals (i.e. they are non-pathogenic or inactivated or neutralized through a decontamination process).

In such cases, the materials or products are NOT considered to pose a health risk and are therefore not subject to transport regulations providing certain provisions are followed, unless it meets the criteria for “dangerous goods” in another class. Specific examples of these complete exceptions include:

- cultures where the biological agent is non-pathogenic to humans or animals;
- patient specimens for faecal occult blood screening samples, or testing using a dried blood spot;
- biological products, such as blood/blood products for transfusion, or body parts for transplant;
- medical or clinical waste, which has been appropriately decontaminated using inactivation methods, such as autoclaving or incineration;
- medical equipment, which has been drained and confirmed to be free of any contaminated liquid; and
- environmental samples (e.g. food, soil, water) shipped for investigational purposes, but which are not thought to pose a risk of infection to humans or animals, which also fall under this definition.

However, in the cases when these exempted goods are transported by air, modal regulations stipulate that they must be transported using a basic triple packaging system consisting of three components: a leak-proof primary receptacle, a leak-proof secondary packaging, and an outer packaging of adequate strength for its capacity, mass and intended use, with at least one surface having minimum dimensions of 100 mm × 100 mm.

For liquids, absorbent material in sufficient quantity to absorb the entire contents must be placed between the primary receptacle(s) and the secondary packaging, so that, during transport, any release or leak of a liquid substance will not reach the outer packaging and will not compromise the integrity of the cushioning material. Once contained in an appropriate triple packaging system, exempt specimens are not subject to any other infectious substances regulations. For more detailed information on the components of an appropriate triple packaging system, please refer to Section 6.1 on packaging.

4.6.1 Exempt human or exempt animal specimens

Exempt human specimens and exempt animal specimens are patient specimens for which there is a minimal likelihood that pathogenic biological agents are present. This special type of exemption includes specimens being transported for testing that is unrelated to infectious disease, such as blood or urine markers (e.g. cholesterol, glucose, hormones, pregnancy, drug and alcohols), biopsies (e.g. antigenic markers for certain cancers) or immunological investigations (e.g. vaccine-induced immunity or auto-immune responses) where infection is not suspected. Sound, professional judgement is required to determine whether a patient specimen may be exempted under this definition, based on known medical history, symptoms, individual circumstances of the source (human or animal), and endemic local conditions.

Note: This definition does not apply to medical or clinical wastes with a low likelihood of pathogenic biological agents being present, which should continue to be sub-classified as infectious substances under the applicable nomenclature described in Section 5.2.2.

Samples, which have been professionally defined as exempt human specimens or exempt animal specimens, must be contained in a basic triple packaging system. More information on the basic triple packaging system may be found in Section 6.1. of the UN Model Regulations. Exempt substances are not assigned to any UN number.

The outermost layer of the package must be marked with the words “Exempt human specimen” or “Exempt animal specimen”, as appropriate. Exempt human specimens and exempt animal specimens, which have been appropriately marked and labelled, would then be considered safe for transport and not subject to further infectious substance regulations.

4.6.2 Used medical devices or equipment

Medical devices or equipment potentially contaminated with or containing infectious substances, which are being transported for disinfection, cleaning, sterilization, repair or evaluation, must be packaged in such a way that, under normal transport conditions, they cannot break, be punctured or leak their contents.

Packagings must be marked with the words “USED MEDICAL DEVICE” OR “USED MEDICAL EQUIPMENT”, as appropriate.

This exception does not apply to:

- a. medical waste (UN 3291 and UN 3549);
- b. medical devices or equipment contaminated with or containing infectious substances in Category A (UN 2814 or UN 2900); and
- c. medical devices or equipment contaminated with or containing other dangerous goods that meet the definition of another hazard class.

SECTION 5.

Classification of infectious substances

If professional judgement finds that the material to be shipped is reasonably expected to contain biological agents capable of causing disease in humans or animals, and cannot be defined as an exemption, it is an infectious substance. Classification of an infectious substance must therefore be made according to the materials composition and the level of risk it poses to human or animal health. It is this classification that will be used to assign the substance a proper shipping name and a UN number that will be used in all aspects of the package preparation, including its packaging composition, marking and labelling, and for documentation purposes.

5.1 Dangerous goods classes and divisions

The first step of classification is to assign a class and division. These classes and divisions can be found in the *UN Model Regulations*. An overview of all the different dangerous goods classes is shown in Table 2.

Table 2. Overview of dangerous goods classes and divisions

Dangerous goods class
Class 1: Explosives
Class 2: Gases
Class 3: Flammable liquids
Class 4: Flammable solids; Substances liable to spontaneous combustion; Substances which, in contact with water, emit flammable gases
Class 5: Oxidising substances and organic peroxides
Class 6: Toxic and infectious substances Division 6.1: Toxic substances Division 6.2: Infectious substances
Class 7: Radioactive material
Class 8: Corrosive substances
Class 9: Miscellaneous dangerous substances and articles, including environmentally hazardous substances

Note: Divisions for classes other than Class 6 are not listed in this table. For more detailed information on other dangerous goods classes and divisions, please refer to the *UN Model Regulations*.

All infectious substances are assigned to Dangerous Goods Division 6.2 Infectious Substances are “substances which are known or are reasonably expected to contain pathogens. Pathogens are defined as micro-organisms (including bacteria, viruses, parasites, fungi) and other agents such as prions, which can cause disease in humans or animals.”

Toxins from plant, animal or bacterial sources, which do not contain any infectious substances or toxins that are not contained in substances which are per definition infectious substances, should be considered for classification in Division 6.1 and assigned to UN 3172.

For transport purposes, infectious substances should never be packaged together with goods from other classes. However, in some cases, substances from other classes may be employed for cooling and/or preservation purposes. This includes flammable liquids (included in Class 3, such as ethanol, methanol, and pyridine), or dry ice (a carbon dioxide solid included in Class 9). More details about how to treat these substances when shipped together with an infectious substance is discussed later in Sections 6.5 and 6.6.

5.2 Infectious substance categories

Once classified as a dangerous good under Division 6.2 of the *UN Model Regulations*, the material must then be further sub-classified, based on the material composition, type of biological agent present, and severity or harm that may be caused by that biological agent. The following sections provide an overview of the various sub-classifications of infectious substances, including the official nomenclature (proper shipping name and UN number) that should be assigned to them for transport purposes. A simplified summary of how to classify and sub-classify infectious substances is also provided in Fig. 3.

5.2.1 Category A

“An infectious substance which is transported in a form that, when exposure to it occurs, is capable of causing permanent disability, life-threatening or fatal disease in otherwise healthy humans or animals.”

In other words, if the substance were released from the craft carrying it and/or protective packaging used during the transportation, it could have severe consequences on the health of any human or animal that came in contact with it.

Any of the material definitions from the above paragraphs 4.1 to 4.5 in this document may be sub-classified as Category A if it is known, or is reasonably expected, to contain a biological agent that meets the criteria above. Indicative lists of the biological agents that may meet the criteria for a Category A infectious substance are provided in many transport regulations and modal agreements. A copy of the indicative list from the *UN Model Regulations* is provided in Annex 3 of this document. It is important to note, however, that many biological agents in this list will only meet the definition for a Category A infectious substance when being transported as cultures.

It should be noted that not all “forms” of an infectious substance render it capable of causing infection in exposed individuals, even when the same biological agent is present. For example, *Mycobacterium tuberculosis* is only considered capable of causing severe harm to exposed individuals if it is transported as cultures.

There are two different UN numbers in the *UN Model Regulations* and proper shipping names associated with Category A infectious substances. The proper shipping name is shown below in bold (dark) type or in uppercase (capital) letters, whereas the descriptive text is shown in light type or lowercase letters within the respective dangerous goods regulations.

- Infectious substances capable of causing disease in humans, or both humans and animals, are assigned to UN 2814, and a proper shipping name of **INFECTIOUS SUBSTANCE, AFFECTING HUMANS**.
- Infectious substances capable of causing disease only in animals are assigned to UN 2900, with the proper shipping name of **INFECTIOUS SUBSTANCE, AFFECTING ANIMALS** only.

The technical name of the hazardous biological agent present contained within the infectious substance must be provided in parentheses () after the proper shipping name on the dangerous goods transport document, if known, but need not be shown on the package. An example is UN 2814, Infectious substance affecting humans (*Mycobacterium tuberculosis* cultures).

If the biological agent is unknown but is thought to meet the definition for Category A infectious substance, “*suspected Category A infectious substance*” must be provided in parentheses () after the proper shipping name on the dangerous goods transport document but need not be shown on the package.

Ultimately, accurate sub-classification of an infectious substance as Category A, and assignment of the appropriate UN number and proper shipping name, requires sound professional judgement. New or emerging pathogens may not appear in indicative lists although their biological characteristics are similar to those associated with Category A.

A pathogen risk assessment must be performed to determine whether the unknown biological agents within the infectious substance are capable of causing severe harm to humans and/or animals, and be based on known medical histories, symptoms, endemic local conditions and the source or origins of the infectious substance. If there is any uncertainty around whether the infectious substance meets the criteria for Category A, a cautious approach should be taken, and Category A assigned.

Medical or clinical wastes with Category A infectious substances must be assigned to UN 2814, UN 2900 or UN 3549, as appropriate. The proper shipping names are **MEDICAL WASTE, CATEGORY A, AFFECTING HUMANS** solid or **MEDICAL WASTE, CATEGORY A, AFFECTING ANIMALS** only, solid. Infectious substances generated from the medical treatment of humans or veterinary treatment of animals may be assigned to UN 3549. The UN 3549 entry must not be used for waste from bioresearch or liquid waste. This UN number is forbidden as cargo in air transport, unless prior approval is obtained from the appropriate authority of the state of origin and the state of the operator under the written conditions established by those authorities.

Wastes should be transported under the requirements of the appropriate class considering their hazards and the criteria presented in the *UN Model Regulations*. Wastes not otherwise subject to these Regulations but covered under the Basel Convention may be transported under Class 9 of the *UN Model Regulations*.

5.2.2 Category B

Infectious substances are sub-classified as Category B when they contain biological agents capable of causing infection in humans or animals, but NOT meeting the criteria for Category A (i.e. the consequences of an infection are not considered severely disabling or life-threatening).

With the exception of substances containing high risk biological agents, in forms listed in Annex 3, most shipments of infectious substances can be transported under Category B.

- The UN number and proper shipping name for most shipments of Category B infectious substances is UN 3373, BIOLOGICAL SUBSTANCE, CATEGORY B.

Regarding medical or clinical wastes, if the infectious substances are defined as clinical or medical wastes, and contain an infectious biological agent (even a minimal likelihood), which does not fit the criteria for Category A, they must be assigned to UN 3291 and given a proper shipping name, which reflects their contents and/or origin. According to the *UN Model Regulations*, proper shipping names may include:

- BIOMEDICAL WASTE, N.O.S.
- CLINICAL WASTE, UNSPECIFIED, N.O.S.
- MEDICAL WASTE, N.O.S.
- REGULATED MEDICAL WASTE, N.O.S.

Fig. 3. A simplified overview of the process of defining and classifying infectious substances

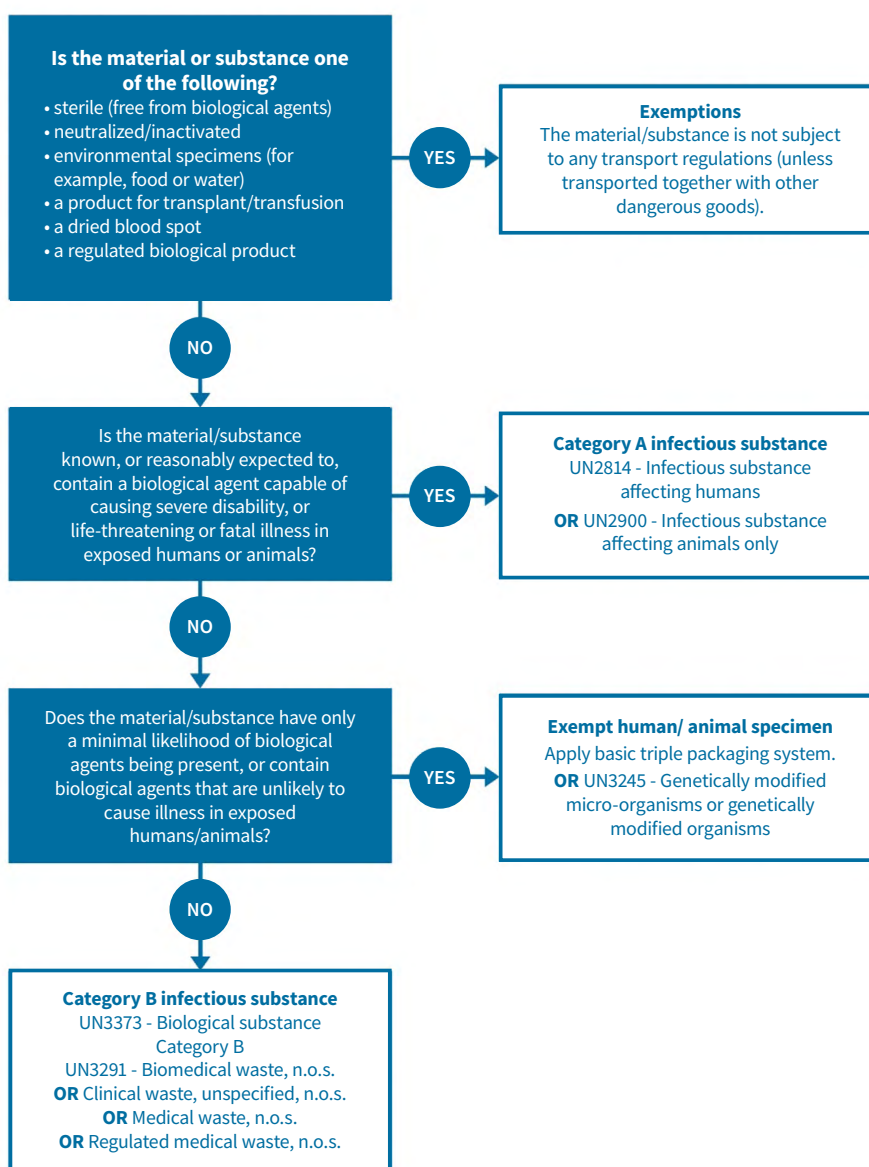

SECTION 6.

Preparing packaging requirements

When moved between the point of origin, cargo transport units, warehouses and its destination, a package of infectious substances can be subject to challenges, including movement, vibrations, changes of temperature, humidity and pressure. It is therefore essential that the packaging used to contain infectious substances during transport is of good quality and strong enough to withstand the challenges that could be faced. For this reason, infectious substances must be contained in a triple-layered packaging system, where redundant layers of packaging and sufficient amounts of absorbent material can be used to control leakages and/or breaches of containment.

A basic triple packaging system, as described in Section 6.1, can be used to transport exempt human specimens or exempt animal specimens by all modes of transport. These additional requirements not only ensure safe containment in various modes of transport, but also help stakeholders in being able to verify that the packaging material used is of an appropriate strength and quality. Further specifications for the triple packaging system may also be required if other dangerous goods are present, such as when dry ice is used as a coolant.

The *UN Model Regulations*, as well as other modal agreements, produce information sheets that outline the detailed packaging requirements for various classifications and sub-classifications of dangerous goods. These instruction sheets are generally referred to as packing instructions, of which four may be applicable to the shipment of infectious substances. These include:

- P620 for Category A infectious substances, affecting humans (UN 2814) and affecting animals (UN 2900);
- P650 for Category B infectious substances assigned to UN 3373;
- P621 for Medical or Clinical Wastes containing a Category B infectious substance (assigned to UN 3291); and

The carriage of infectious substances as hand carriage on passenger aircraft – even in diplomatic pouches – is strictly prohibited.

For the purpose of transport, any material defined that falls under the definition of “exempt human specimen” or “exempt animal specimen” can be transported in a triple-layer packaging system, such as the one described here, without being subject to any further infectious substance regulations.

There is no limit to the quantity of exempt human or animal specimen that may be carried per package, on any mode of transport.

- P622 for Medical waste, Category A, affecting humans or Medical waste, Category A, affecting animals (assigned to UN 3549).

A packing instruction, PI954, is also provided in the *ICAO Technical Instructions* for the use of dry ice as a coolant, which may be applicable to infectious substances being transported by air.

An overview of the contents of some of these packing instruction requirements are provided in the following section, with additional information relating to the marking and labelling requirements in Section 7.

6.1 A basic triple packaging system

As the name suggests, any package used to contain an infectious substance must be comprised of three layers. A picture of a basic triple packaging is shown in Fig. 4.

1. The primary receptacle, containing the infectious substance, must be watertight, and impermeable to the substance held within (i.e. leakproof – for liquid, or sift-proof – for solids). The primary receptacle should be appropriately labelled as to content.

The primary receptacle must not become punctured, broken, weakened, or affected by contact with the infectious substance. For example, the primary receptacle should not be corroded by preservation media used to hold a patient specimen.

If the infectious substance contains a liquid, or semi-liquid substance, the primary receptacle must be wrapped in enough absorbent material to absorb all the fluid in the rare event of a breakage or leakage.

2. A second watertight, leakproof or sift-proof container should then be used to enclose and protect the primary receptacle and its absorbent material.

Several primary receptacles may be placed in a single secondary container, provided they are all infectious substances of the same class. If the primary receptacle is fragile, each must be wrapped and placed in the secondary container individually, or in a way that prevents contact between them. Cushioning material may be required to secure the primary receptacles within the secondary container.

3. A third, outer layer of packaging is used to protect the secondary container from physical damage while in transit. It must therefore be of an appropriate strength for the weight, size, and composition of the inner packages to be protected. At least one surface of the outer packaging must have a minimum dimension of 100 mm × 100 mm.

Fig. 4. Examples of basic triple packaging materials



Specimen data forms, letters, supplementary documentation, and other types of information that identify or describe the infectious substance should be placed between the secondary container and outer layers of packaging. If necessary, these documents may be taped to the secondary container.

6.2 Packing instruction P650 (Category B infectious substance requirements)

Packing instruction P650 provides a slightly more detailed set of triple packaging requirements than that of the basic triple packaging system. Infectious substances sub-classified as Biological Substance, Category B (UN3373) and packaged in accordance with P650 may be considered safe and compliant for all modes of transportation and are not subject to any other packaging requirement outlined in the *UN Model Regulations*, such as for the more detailed testing and approval processes, which will be required for the packaging of Category A infectious substances. For this reason, it is generally feasible to source P650-compliant packaging materials from local manufacturers and suppliers. In this case, the manufacturer/supplier should provide clear instructions for the user (e.g. shipper, sender, or consignee) on how to correctly fill and close the package ensuring full compliance with P650.

It should be noted that there is no comprehensive list of suppliers of packaging that complies with packing instructions P650. However, an Internet search using a suitable international or national search engine usually provides appropriate information, as well as access to national regulations. Search phrases such as “UN packaging” and “UN infectious substance packaging” produce extensive results. Carriers and forwarding agents (e.g. couriers or logistics companies) should also be able to supply details of local suppliers or local companies that can provide such information.

In addition to the basic triple packaging system, additional stipulations outlined in P650 include the following.

- For surface transport, either the secondary or outer packaging must be rigid (i.e. the secondary packaging must be rigid if the outer packaging is soft, or the outer packaging must be rigid if the secondary container is soft). The latter is the most commonly applied arrangement, as a rigid outer packaging is always required for air transport.
- The complete triple package must be capable of passing a 1.2m “drop test” to prove that is of an appropriate strength and quality.
- The primary receptacle OR the secondary packaging must be capable of withstanding internal pressure of 95kPa (0.95 bar). This must be tested using an appropriate methodology, which is based on the receptacle or packaging type being used (e.g. internal hydraulic or pneumatic pressure gauges, or external vacuum testing).
- An itemized list of contents shall be enclosed between the secondary container and outer packaging (for air transports).

Quantity limits (Category B)

For shipments being carried by air (passenger or cargo aircraft), the primary inner receptacle must not contain more than **1L** and the outer packaging must not contain more than **4L** of material. This excludes any quantity of coolants used, such as dry ice or liquid nitrogen.

For shipments being carried via surface transport (road, rail or maritime), there are no quantity limits per package.

Further details on test requirements, such as for drop-testing and pressure differential testing, are outlined in Chapter 6.3 (6.3.5.3) of the *UN Model Regulations*.

Please find below in Fig. 5 an example of triple packaging.

Fig. 5. Example of triple packaging materials that may be used to comply with P650 for Category B infectious substances

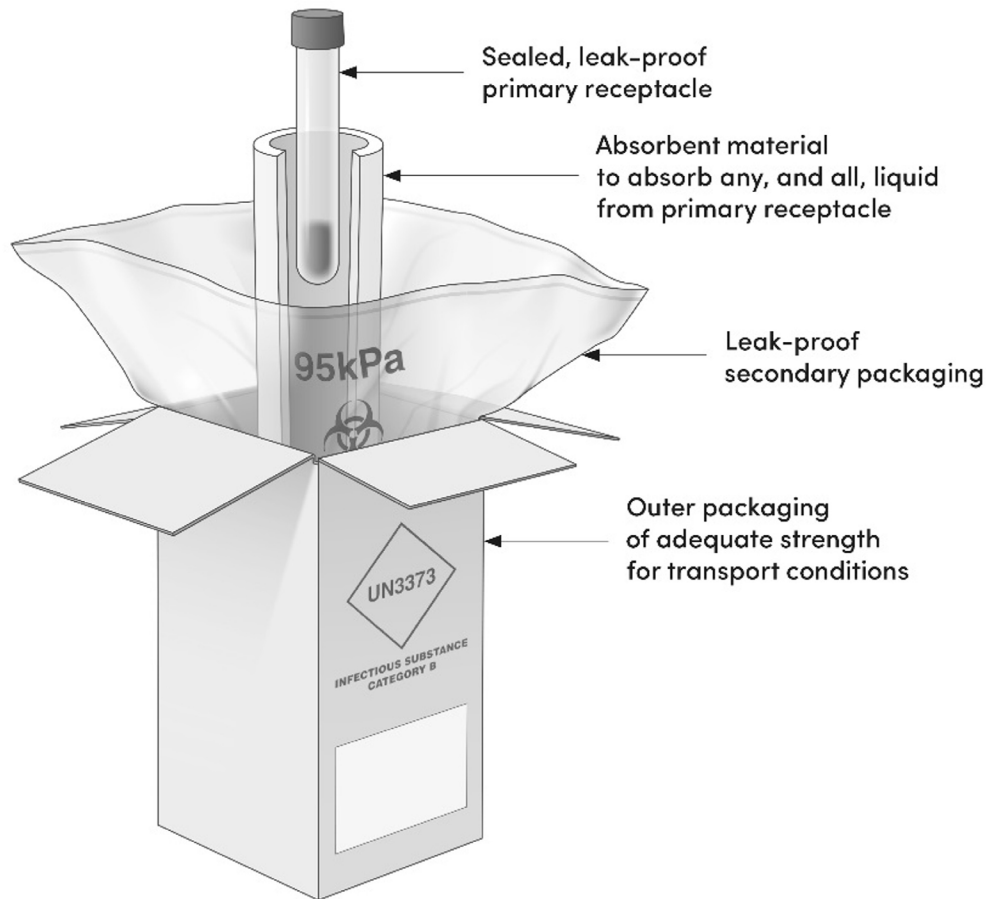

6.3 Packing instruction P620 (Category A packaging requirements)

Packing instruction P620 outlines the requirements and special packaging provisions that must be met for approval for use with Category A infectious substances. In addition to the components of a basic triple packaging system, packaging for Category A infectious substances must include the following. A picture of an example for Category A infectious substances is shown in Fig. 6.

1. Primary receptacle

- Whatever the intended temperature of the consignment, the primary receptacle OR the secondary packaging must be capable of withstanding a pressure differential of not less than 95kPA (0.95 bar) as well as temperatures in the range of -40°C to +55°C.
- When the shipment is being carried at ambient temperature (or above), the primary receptacle must be glass, metal or plastic. A leakproof seal should be provided (e.g. heat seal, skirted stopper, or metal crimp seal). If screw caps are used, they must be secured (e.g. paraffin sealing tape, tape, or manufactured locking closure).
- Lyophilized substances may also be transported in primary receptacles that are flame-sealed glass ampoules or rubber-stopped glass vials fitted with metal seals.

2. Secondary container

- a. As already stated above, either the primary receptacle or this secondary container must be capable of withstanding a pressure differential of not less than 95kPA (0.95 bar) and temperatures in the range of -40°C to +55°C.

3. Third, outer packaging

- a. This must be rigid.
- b. The smallest external dimension shall be not less than 100 mm.
- c. An itemized list of contents shall be enclosed between the secondary container and outer packaging, including the proper shipping name and technical name, in parentheses, of the biological agent present in the infectious substance. When the infectious substance to be transported is unknown but suspected of meeting the criteria for inclusion in Category A, the words “suspected Category A infectious substance” must be shown in parentheses following the proper shipping name.

Fig. 6. An example of triple packaging materials that may be used for Category A infectious substances

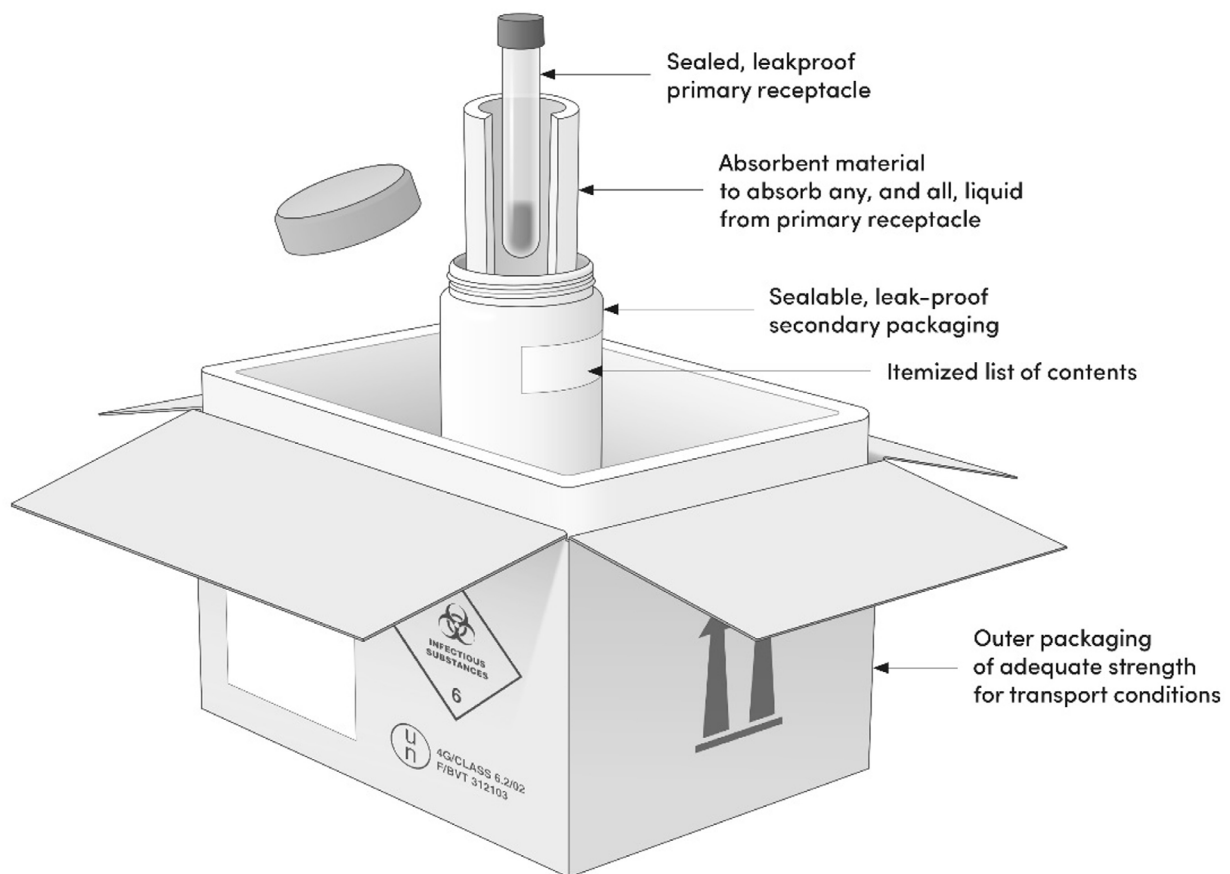

The ability of packagings for Category A infectious substances to meet the requirements above must also be properly verified. The *UN Model Regulations* stipulate that Category A infectious substances must only be transported in a triple packaging system, which has been tested according to the “Requirements for the Construction and Testing of Packagings for Division 6.2 Infectious Substances of Category A”, which detail the challenges and conditions that must be applied to the complete triple packaging system in order to verify the material quality. The tests described include dropping, stacking and puncture tests, and the application of pressure, water spray and cold/high temperatures. For more details on the specific testing requirements, please consult Chapter 6.3 (6.3.5.3) of the *UN Model Regulations*.

Given the detailed and technical nature of the testing required, the manufacture of Category A approved packagings is generally performed by dedicated packaging specialists and governed by a quality assurance program, overseen by a competent authority. Manufacturers should be able to demonstrate compliance with the requirements by providing documentation and evidence of the methods used, and results obtained from package testing. Packagings, which have been manufactured (and approved) in accordance with the UN Model Regulations requirements, are then to be marked with the United Nations packaging symbol, followed by a series of numerals and symbols that provide information on how, when and where the packaging was manufactured and approved. Description of the features of the UN specification mark for Category A infectious substances can be Found in Fig. 7.

Quantity limits (Category A):

For shipments being carried in the cargo hold of passenger aircraft, no more than 50 mL or 50 g of Category A infectious substance per package is allowed.

For shipments being carried on a cargo-only aircraft, no more than 4 L or 4 kg of Category A infectious substance per package is allowed.

For shipments being carried via surface transport (e.g. road, rail or maritime), there are no quantity limits per package.

Fig. 7. Description of the features of the UN specification mark for Category A infectious substances packaging (for UN 2814 and UN 2900)

	4	G	/	Class	6.2	/	21	/	GB	/	2470
1	2	3	4	5	6	7	8	9	10	11	12

This mark comprises:

1. the United Nations packaging symbol;
2. an indication of the type of packaging (in this example, a fibreboard box (4G));
3. an indication that the packaging has been specially tested to ensure that it meets the requirements for Category A infectious substances (Class 6.2);
4. the last two digits of the year of manufacture (in this example, 2021);
5. the competent state authority that has authorized the allocation of the mark (in this example, GB, signifying United Kingdom of Great Britain and Northern Ireland); and
6. the manufacturer’s code specified by the competent authority (in this example, 2470).

6.4 Packing instruction P621 (medical or clinical waste requirements)

Medical or clinical waste, which contains biological agents consistent with the classification of Category B infectious substances, is assigned to UN 3291. UN 3291 is then subject to the packaging P621 requirements outlined in the UN Model Regulations.

Medical or clinical waste classified under UN 3291 does not have to conform to a triple layer of packaging. Packagings for UN 3291 may comprise various types, including drums, boxes or jerricans, provided that these packagings conform to the general provisions outlined in the *UN Model Regulations* for a “Packing group II” (substances presenting medium danger) level of performance. Packing group II performance levels may differ for liquid or solid infectious substances. It should be noted that infectious substances containing liquid must be packed with sufficient absorbent material to absorb all liquid present.

Finally, packagings for UN 3291 (e.g. Biomedical Waste, n.o.s.; Clinical Waste, Unspecified, n.o.s.; Medical Waste, n.o.s.; and Regulated Medical Waste, n.o.s.) intended to contain sharp objects, such as broken glass and needles, must be resistant to puncture and retain liquids under the performance test conditions for the packaging.

6.5 Packing with coolants

A coolant (also known as a refrigerant) is a substance used to maintain a cool temperature around the dangerous goods, to preserve its integrity until it reaches its final destination. Many of the most commonly used coolants are themselves dangerous goods of other classes. Therefore, in addition to following the requirements of the relevant packing instructions for infectious substances (i.e. P620, P621 and P650), other packing requirements specific to these substances may need to be observed.

Some of the general requirements for packaging used to contain infectious substances together with a coolant material include the following:

- Packaging used must be capable of maintaining integrity at the temperature afforded by the coolant.
- The coolant must be placed between the secondary container and outer packaging, or in an overpack used to transport multiple packages together (for more information on overpacks, see Section 6.7).
- Persons handling the packages should be appropriately trained on the coolants in use.
- Coordination between the shipper and carrier should ensure that the cargo transport unit being used to carry the packages is well ventilated for the coolants in use. This is especially important in the case of air transport, to ensure ventilation safety procedures are followed. The carrier may also need to ensure cargo transport units are appropriately marked with warning and hazard labels.

Special provisions applicable to the use of dangerous goods as coolants may be found in Chapter 5.5.3 of the *UN Model Regulations*.

An overview of some of the more specific packing requirements for the commonly used coolants is provided in the following section. Additional requirements necessary for the marking, labelling and documentation of packages containing coolants will be briefly described in Section 7. However, for detailed information, the relevant chapters of the *UN Model Regulations* should be consulted.

6.5.1 Wet ice

Wet Ice is the term used to describe frozen, solid water. Wet ice is not considered a dangerous good and is therefore not assigned a proper shipping name or UN number. If wet ice is used, the outer packaging must be leak-proof to prevent water leakage, as ice will melt over time.

6.5.2 Dry ice

Dry Ice is one of the most commonly used coolants for the transport of infectious substances. Dry ice belongs to Dangerous Goods Class 9: Miscellaneous Dangerous Substances and Articles, Including Environmentally Hazardous Substances. It is assigned the proper shipping name “Dry Ice” or “Carbon Dioxide, Solid” and the UN number UN 1845.

Both P620 and P650 include packaging requirements for infectious substances shipped with dry ice. Both packing instructions describe the importance of ensuring that the outer packaging must be comprised of a material which permits the release of carbon dioxide gas, such as Styrofoam. This is because dry ice sublimates over time, turning from a carbon dioxide solid into a carbon dioxide gas, which is heavier than air and can create a build-up of pressure that could lead to an explosion if not effectively released. For this reason, adequate ventilation safety procedures should be followed for the cargo transport unit carrying the package. Inserts or supporting material for the secondary container should be considered, to ensure it remains secure inside the outer package even once the dry ice has dispersed.

The *ICAO Technical Instructions* provides a specific packing instruction, PI954, which describes the necessary requirements for any dangerous goods shipment containing dry ice when transported by air.

6.5.3 Liquid nitrogen

Liquid nitrogen is also commonly used in the transport of infectious substances and belongs to Dangerous Goods Class 2: Gases. It is assigned the proper shipping name “nitrogen, refrigerated liquid” and the UN number UN 1977. Liquid nitrogen is used when extremely low temperatures are required to maintain the integrity of the shipment. For this reason, both the primary and secondary packaging must be able to withstand such a temperature extremity without damage.

Due to their detail and complexity, this document does not provide further guidance on the regulations applicable to shipments of liquid nitrogen (except for the use of liquid nitrogen as part of dry shippers as described in Section 6.5.4). For more detailed information about shipments using free liquid nitrogen as a coolant, please directly consult the *UN Model Regulations* and/or other applicable modal agreements.

6.5.4 Dry shippers

A dry shipper is a specialized outer packaging material, which is insulated with a layer of liquid nitrogen fully absorbed into a porous material. The careful design ensures that liquid nitrogen is kept well contained inside the walls of the outer layer, even when its orientation is changed, and pressure is prevented from building up inside.

Liquid nitrogen contained in a properly manufactured dry shipper is not subject to any other dangerous goods requirements. This means that the package would not be subject to the detailed requirements of free liquid nitrogen while still maintaining the extremely low temperatures liquid nitrogen can afford.

The dry shipper must be appropriately marked and labelled to indicate the presence of infectious substances inside. For more information, please refer to Section 7 on marking and labelling. The use of a dry shipper also needs to be indicated appropriately in shipment documentation, which is described in more detail in Section 8.

6.6 Packing with stabilizers

A stabilizer is a chemical substance placed together with the infectious substance in the primary receptacles, and is used for maintaining viability, preventing degradation or preserving antigen integrity. Stabilizers commonly used with infectious substances include sorbitol, fetal bovine serum (FBS), alcohols, alcohol solutions or formaldehydes.

As with coolants, stabilizers may themselves be dangerous goods assigned to different dangerous goods classes.

Subject to the susceptibility of each biological agent, some stabilizers may cause inactivation of the biological agent, removing its ability to cause infection in humans or animals. In this case, sound professional judgement may be used to reclassify the substance under the definition of an exemption.

Other dangerous goods must not be packed in the same packaging as Division 6.2 infectious substances unless they are necessary for maintaining the viability, stabilizing or preventing degradation, or neutralizing the hazards of the infectious substances. A quantity of 30 mL or less of dangerous goods included in classes 3 (e.g. alcohols), 8 (e.g. formaldehydes) or 9 (e.g. GMOs), permitted as “Dangerous Goods in Excepted Quantities”, may be packed in each primary receptacle containing infectious substances. When these small quantities of dangerous goods are packed with infectious substances in accordance with packing instruction P620 or P650, no other requirements in the *UN Model Regulations* need to be met. For more detailed information on accepted quantities of dangerous goods, please refer to Chapter 3.5 of the *UN Model Regulations*.

6.7 Packing in overpacks

An overpack is an enclosure used by a single shipper to contain one or more packages and to form one handling unit for the convenience of handling and stowage. If dry ice is being used to protect contents, the overpacks may be comprised of insulated vessels or flasks to allow dissipation of carbon dioxide gas.

Whenever an overpack is used, the required marks and labels shown on the packages of infectious substance inside must be repeated on the outermost layer of the overpack (unless already clearly visible, for example, through a clear plastic wrapping). Overpacks must be marked with the word “OVERPACK” in lettering at least 12mm high.

6.8 Re-cycling packaging

Before an empty packaging is returned to the consignor, or sent elsewhere, it must be disinfected or sterilized to nullify any hazard, and any label or mark indicating that it contained an infectious substance must be removed or obliterated. If the packaging is being re-used, the shipper must ensure that all marks and labels reflect the substances actually being shipped and not the substance it was used for previously.

Re-used packaging must maintain its ability to comply with relevant quality testing procedures outlined in later sections on Category A and Category B packaging requirements in the *UN Model Regulations*. If packaging material becomes damaged or reduced in strength, it should no longer be used.

SECTION 7.

Marking and labelling

Once the correct packaging materials have been assembled, they must be properly marked and labelled to provide information about the contents of the package, the nature of the hazard, and the packaging standards that have been applied. All marks and labels must be placed in a way that is clearly visible and not covered by any other label or mark.

7.1 Marks

Examples of all marks that may be applicable to infectious substances shipments are provided in Table 3.

The following marks must be provided on the outer package of all infectious substances:

- shipper's (e.g. sender's, consignor's) name and address;
- receiver's/consignee's name and address;
- UN number of the infectious substance, followed by the proper shipping name of the substance – technical names need not be shown on the package, and exempt substances do not have a UN number; and
- when a coolant is used (e.g. dry ice), the UN number and the proper shipping name of the coolant must be provided, followed by the words 'AS COOLANT'. In addition, the net quantity of coolant present should be provided.

In addition, the following marks may apply, depending on the infectious substance classification.

The term “net quantity” refers to the weight or volume of the dangerous goods contained in a package, excluding the weight or volume of any packaging material.

The net quantity of dry ice may be particularly important for handling of the shipment as, along with the thermal capabilities of the packaging, it will determine how long a cool temperature can be maintained for preserving or stabilizing the infectious substance in transit. In some cases, the net quantity of dry ice may need to be replenished while in transit to maintain cold chain through a long journey.

The net quantity of the infectious substance is also important for biosecurity and chain of custody purposes, as well as providing information for assessing biosafety risks if a spillage or leakage were to occur.

Fig. 8. The UN Specification Mark

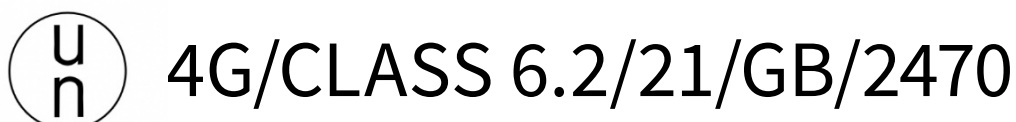

For Category A infectious substances, the following applies.

- The UN packaging symbol and certification marks (numerals and letters) must be displayed. An example of such a packaging mark is shown in Fig. 8. If an overpack is being used, the UN packaging symbol and certification marks will not appear on the overpack.
- The name and telephone number of a person responsible, who is knowledgeable about the shipment, must be provided.

For Category B infectious substances, the mark shown below in Fig. 9 must be used.

- **Specifications.** The width of the line forming the square must be at least two mm, and the letters/numbers must be at least six mm high. For air transport, each side of the square shall have a minimum dimension of 50 mm x 50 mm.
- **Colour.** No colour is specified, however, the mark must be displayed on the outer packaging, on a background of contrasting colour, and be clearly visible and legible.
- **Proper shipping name.** This name (BIOLOGICAL SUBSTANCE, CATEGORY B) in letters at least six mm high must be displayed adjacent to the mark.

Fig. 9. An example of the mark that must be used for Category B infectious substances



Table 3 below shows different marks that are used in the shipment of infectious substance.

Table 3. Marks associated with infectious substances shipments

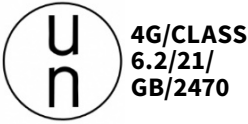
<p>SHIPPER PETER SMITH TIMELY LOGISTICS BP 102 I-0956666 NOLAND Netherlands</p> <p>RECEIVER AB JONES STONE LAB RUE DE L'ESSAI F-9867 ADIEU France</p>	<p>'To' and 'From' marks required for all packages, showing the name and address of the shipper and receiver</p>	<p>UN2814 Infectious Substance Affecting Humans</p>	<p>The UN number and Proper Shipping Name marks (for Category A packages)</p>
	<p>The UN number and Proper Shipping Name marks (for Category B packages sub-classified as UN3373)</p>	<p>EMERGENCY CONTACT 24H/7 Dr RED PEPPER: +67 56 45 34 23</p>	<p>A 24-hour emergency contact person must be marked on all Category A infectious substance packages.</p>
	<p>Marking of UN specification packagings, indicating outer packaging has been tested according to UN standard, is required for all Category A infectious substance packages.</p>	<p>UN1845 CARBON DIOXIDE, SOLID AS COOLANT Net 3 kg</p>	<p>The UN number and proper shipping name followed by the words "AS COOLANT". The net quantity of coolant present should also be provided.</p>

7.2 Labels

There are two types of labels (hazard and handling labels) that may need to be used for packages of infectious substances.

Special provisions for the labelling of infectious substances packages, require that in addition to the primary hazard label (model No. 6.2, shown in Table 4), infectious substances packages shall bear any other label required by the nature of the contents.

7.2.1 Hazard labels

Hazard labels are always presented in the form of a square set at an angle of 45° (i.e. diamond-shaped).

The minimum dimensions are 100 mm x 100 mm. If the package is very small, the label size may be reduced proportionately (minimum dimensions 50mm x 50mm), provided all elements of the label are easily visible. Fig. 10 shows the template for hazard labels.

One hazard label(s) for each dangerous good in the package (unless specifically exempted) must be affixed. This means there may be more than one hazard label required if the infectious substance is being shipped with a coolant (e.g. dry ice).

Examples of hazard labels that may be applicable to infectious substances shipments may be seen in Table 4.

Fig. 10. Template for hazard labels

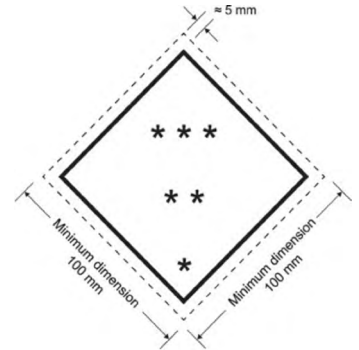

Table 4. Hazard labels applicable to infectious substances shipments

<p>The label is a white diamond with a black border. At the top is a biohazard symbol. Below it, the text reads: 'INFECTIOUS SUBSTANCE', 'IN CASE OF DAMAGE OR LEAKAGE', 'IMMEDIATELY NOTIFY PUBLIC HEALTH AUTHORITY'. At the bottom is the number '6'.</p>	<p>Label. Infectious substances hazard label</p> <p>Required for. Compulsory for all packages containing Category A infectious substances</p> <p>Specifications. The upper half of the diamond must display three crescents superimposed on a black circle. The lower half of the diamond may bear the inscriptions: “INFECTIOUS SUBSTANCE” and “In case of damage or leakage immediately notify Public Health Authority” in black colour. The number ‘6’ must be displayed in the bottom corner.</p> <p>Colour. White background, black writing</p>
<p>The label is a white diamond with a black border. The top half contains seven vertical black stripes. The bottom half contains the number '9'.</p>	<p>Label. Miscellaneous dangerous good hazard label</p> <p>Required for. Infectious substance packages containing Class 9 substances, namely dry ice, as coolant</p> <p>Specifications. The upper portion must contain 7 vertical stripes and an underlined number ‘9’ must appear in the bottom corner.</p> <p>Colour. White background, black writing</p>
<p>The label is a green diamond with a white border. It features a white gas cylinder symbol. At the bottom is the number '2'.</p>	<p>Label. Non-flammable, non-toxic gas hazard label</p> <p>Required for. Infectious substances packages containing a Class 2, Division 2.2 compressed gas as a coolant, namely liquid nitrogen</p> <p>Specifications. The label must show a symbol of a gas cylinder with the number ‘2’ in the bottom corner.</p> <p>Colour. Green, with writing in black or white</p>

7.2.2 Handling labels

Handling labels may be found in various shapes, either alone or in addition to hazard labels, depending on the nature and quantity of dangerous goods present. Some of these labels are found in the *ICAO Technical Instructions* and are only obligatory for air transport. Table 5 provides an overview of the most common handling labels.

Table 5. Handling labels that may be applicable to infectious substances shipments

	<p>Label. Orientation arrows</p> <p>Required for. This indicates the presence of a liquid in the package, requiring the packages only be handled in the upright position to prevent leakage. For infectious substances, orientation arrows are required when material in primary receptacles exceeds 50 mL.</p> <p>Specifications. The label must show two arrows pointing in the correct upright direction. They shall be rectangular and of a size that is clearly visible, commensurate with the size of the package. The label must appear on two opposite vertical sides of the package (minimum dimensions 74mm x 105mm). A rectangular border around the arrows is optional.</p> <p>Colour. Black or red arrows on a white, or suitably contrasting, background</p>
	<p>Label. Cargo aircraft only (CAO) label</p> <p>Required for. This indicates that a package of infectious substances contains more than the quantity limits for passenger aircraft and is therefore eligible for transport by cargo aircraft only.</p> <p>Specifications. The minimum dimensions of the label are 120 mm on the horizontal axis and 110 mm on the vertical axis. These dimensions may be halved for small packages of Division 6.2 infectious substances.</p> <p>Colour. Orange background, black writing</p>
	<p>Label. Cryogenic liquid warning label</p> <p>Required for. This is for Infectious substances packages, being transported by air, which contain cryogenic liquids (e.g. deeply refrigerated liquefied gases) as a coolant (e.g. liquid nitrogen). This label must be used in addition to the hazard label for non-flammable, non-toxic gases. This label is NOT required for specialized insulated packagings for liquid nitrogen, known as dry shippers.</p> <p>Specifications. The minimum dimensions are 74 mm on the horizontal axis and 105 mm on the vertical axis. The words "<i>Caution – may cause cold burn injuries if spilled or leaked</i>" are optional and may be included.</p> <p>Colour. Green background, with white writing</p>

SECTION 8.

Documenting shipments

In most cases, the person preparing the infectious substance for shipment (i.e. the shipper, sender or consignor) will not be the person who transports and delivers the package to the final destination. Therefore, it is important that this person prepares any documentation required by applicable regulations to inform those who will be transporting the package (i.e. the carrier, courier or logistician) about how the package was prepared and the dangerous goods that it contains.

Any information provided in transport documents should be easy to read and resilient (i.e. permanent ink that cannot be easily removed). The page number and total number of pages or “Page 1 of 1 pages”, if there is no extension list, must appear on the dangerous goods transport document. Copies of any transport documents must be retained by the sender for a minimum period of three months following the shipment, though different time periods may be required under certain modal agreements or variations.

In some instances, certificates of approval are required from national competent authorities to ship an infectious substance. Generally, these do not need to accompany a shipment, but the shipper must be able to make them available on request.

The following sections describe some of the most commonly required documents for the shipment of infectious substances.

In some cases, electronic data processing (EDP) or electronic data interchanges (EDI) may be used as an alternative to paper documentation but must be done only with the pre-approval of the carrier. Electronic signatures and initials for certifications or declarations in this case will be acceptable. However, the shipper must always be able to produce a paper document copy of all information upon request.

8.1 Dangerous Goods Transport Document (DGTD)

As outlined in the *UN Model Regulations*, a certain minimum set of information should be recorded for any infectious substance in the form of a “Dangerous Goods Transport Document” (DGTD). A DGTD is required for all shipments of Category A infectious substances (UN2814 and UN2900) and for medical or clinical wastes (UN3291 and UN3549). However, Category B infectious substances assigned to UN3373, which are packaged according to packing instruction P650, are said to no longer be subject to these requirements of the *UN Model Regulations*, meaning a DGTD is NOT required.

According to the *UN Model Regulations*, the DGTD may take any form, as long as the minimum information requirements (as outlined in the section below) are met. However, modal agreements or national regulations may also stipulate their own formats for this document, such as the commonly used “Dangerous Goods Declaration (DGD)” form used for air transport. Equivalent variations may be required for shipments by road, sea or rail as described in the relevant modal agreements.

The following information is considered the minimum to meet the *UN Model Regulations* requirements for a DGTD for documenting a shipment of infectious substances. However, it is important to ensure that other regulations for documentation applicable to the shipment are also consulted to ensure any other essential information stipulated by these are also included. For example, shipments by air require additional information, such as departure and arrival airport information, and reference numbers for other transport documents, such as an air waybill. Shippers should check with their carrier/operator to ensure the correct form of the document is used, and for any special instructions that must be followed to ensure it is filled in correctly.

1. **Sender and receiver information.** The name and address of the shipper/consignor and the receiver/consignee of the dangerous goods shall be included.
 - For infectious substances packages, the name and contact phone number for a person responsible, and knowledgeable about the infectious substance, must also be provided (who may be the same or different to the shipper or receiver), and should be available for contact at all times throughout the shipment process. Fig. 11 is an example of how emergency contact information is shown.

Fig. 11. An example of emergency contact information to be provided on a DGTD

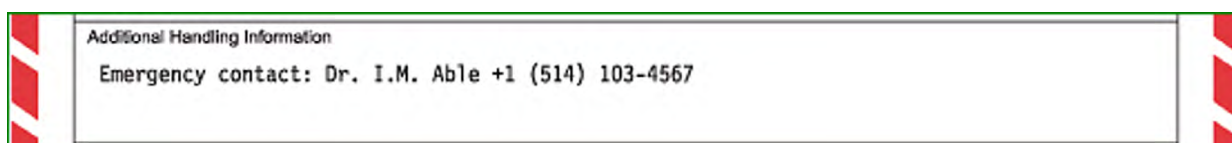

2. **Date.** This is for when the transport document (or electronic copy of it) was signed.
3. **Description of the dangerous goods.** This should include information in the following order:
 - a. UN number (e.g. UN 2814, UN 2900);
 - b. proper shipping name (e.g. INFECTIOUS SUBSTANCE, AFFECTING HUMANS.). For Category A infectious substances, the technical name must follow the proper shipping name in parentheses. When the infectious substances to be transported are unknown but suspected of meeting the criteria for inclusion in Category A and assigned to UN 2814 or UN 2900, the words “suspected category A infectious substance” must be shown, in parentheses, following the proper shipping name on the Shipper’s Declaration for Dangerous Goods, but not on the outer packagings;
 - c. primary hazard class and/or division (i.e. Division 6.2);
 - d. subsidiary hazard class (Note: infectious substances do not have subsidiary hazards. However, this may be applicable to other dangerous goods, which present multiple hazards. For example, methanol is class 3, and subsidiary hazard class is 6.1);

e.g. UN2814, INFECTIOUS SUBSTANCE, AFFECTING HUMANS (Dengue virus), DIVISION 6.2

- e. If applicable, the packing group for the substance or article, which may be preceded by “PG” (e.g. “PG II”) (Note: infectious substances are not assigned packing groups); and
- f. any other descriptive information required under other applicable national or international regulations.

A description of each dangerous good present in the package is required. Therefore, if a coolant, such as dry ice, is present, two entries will be required under this description.

4. Type and NET quantity of dangerous goods for each package.

- The number of packages, the type/material of outer packaging used (e.g. fibreboard box, plastic drum) and the net quantity of the dangerous goods in each package must be provided. Quantity should be given by volume (e.g. mL, L) or mass (e.g. g, kg) as appropriate.
- If more than one dangerous good is present (e.g. dry ice), then this information for each dangerous good must be provided. If a dry shipper or an overpack is used, this should also be indicated here, following the type and quantity of the individual packages contained within.

e.g. 150 mL
each packed in
3 solid plastic
boxes (3 plastic
boxes x 150 ml)

“NET” refers to the total quantity of the dangerous good alone (e.g. 40 mL net quantity of a bacterial culture).

“GROSS” refers to the total mass of the package (e.g. 50 g (0.05 kg) of culture in 1 kg of dry ice wrapped in 1 kg of packaging materials = gross quantity of 2.05 kg).

5. **Handling requirements.** These are actions, if any, that are required to be taken by the carrier in the treatment of the package. This may be stipulated by the carrier or national/international authorities, but should include as a minimum:

- supplementary requirements for handling (e.g. loading, stowing, unloading); if none are required, a statement saying ‘No such requirements are necessary’ should be provided;
- any restrictions that apply on the mode of transportation that can/must be used;
- whatever the routing used, transport must be made by the quickest possible routing; if transshipment is necessary, precautions must be taken to ensure special care, expeditious handling and monitoring of the substance in transit; and
- emergency arrangements applicable to the package.

6. **Emergency response information.** All shipments of infectious substances in Category A must have the name and telephone number of a person responsible for the shipment marked on the package(s) and on the shipper’s declaration (in the “additional handling information” section). For infectious substances in Category B, UN 3373, the name and telephone number of a person responsible must be provided on the air waybill or on the package.

In addition to emergency contact information, appropriate information should be immediately available for carriers to use in emergency response to accidents or incidents involving infectious substances packages during transport.

This may include contact information for public health authorities, medical or first aid requirements (e.g. prophylaxis for exposed persons) or procedures for spill clean-up.

7. Certification (Shipper's Declaration).

A statement should be given on the document from the shipper, acknowledging that the package has been prepared according to the applicable requirements. This statement must be signed and dated. For air transport the following additional statement is required: "I declare that all of the applicable air transport requirements have been met." Only trained persons are allowed to fill in and sign the Shipper's declaration. An example of a signed and dated shipper's declaration can be found in Fig. 12.

"I hereby declare that the contents of this consignment are fully and accurately described above by the proper shipping name, and are classified, packaged, marked and labelled/placarded, and are in all respects in proper condition for transport according to applicable international and national government regulations."

Fig. 12. An example of a signed and dated shippers declaration

I hereby declare that the contents of this consignment are fully and accurately described above by the proper shipping name, and are classified, packaged marked and labelled/placarded, and are in all respects in proper condition for transport according to applicable international and national governmental regulations. I declare that all of the applicable air transport requirements have been met.	Name of Signatory B. Smith
	Date 1 Jan 2021 Signature (See warning above) <i>B. Smith</i>

8.2 Air waybill

An air waybill is a commonly requested shipping document that is part of the general condition of carriage for any goods via international air transport. Therefore, an air waybill must accompany all shipments of infectious substances, even if a DGTD has already been filled. It is common industry practice for the shipper or shipper's agent/freight forwarder to be the one to prepare the air waybill.

The format of the air waybill will vary across different operators and countries. Much like the DGTD, the air waybill will contain a number of general sections outlining the various information of the shipment, such as the shipper's and receiver's name and address, carrier information, and quantities and types of packages.

However, there are two main sections pertaining to the nature of the hazard that must be carefully filled for infectious substances:

1. "Handling information" box.

- For Category A infectious substances, the statement "Dangerous Goods as per associated Shippers Declaration" must be provided. If applicable (e.g. the volume of substance is >50

Shipments of all goods by air are accompanied with an air waybill, even if they do not contain dangerous goods.

Even exempt human and exempt animal specimens, exempted from all other regulations, may be accompanied by an air waybill.

For these shipments, the phrase "exempt specimens" should be provided in the nature and quantity of goods box of the air waybill.

If shipped with coolant, the proper shipping name, UN number and net quantity of coolant in the package should also be provided.

mL and ≤ 4 L or the weight is >50 g and ≤ 4 kg) the statement “Cargo Aircraft Only” or “CAO” must also be provided.

- b. For Category B infectious substances, the name and telephone number for a person responsible, knowledgeable about the shipment and available throughout the shipment process must be provided on the air waybill or on the package.

2. **“Nature and quantity of goods” box.**

- a. For Category A infectious substances, a general description of the substance can be provided, such as “laboratory samples”, “pathology samples”, or “infectious substance”.
- b. For Category B infectious substances, the UN number, proper shipping name (e.g. “UN3373” “Biological Substance Category B”) and number of packages must be provided (unless these are the only packages within the consignment). If the substance is being shipped with dry ice, the UN number, proper shipping name and net quantity of dry ice should also be provided.

Fig. 13 is an example of the air waybill filled in for a Category B infectious substance.

Fig. 13. Example of an air waybill filled for a Category B infectious substance

Airport of Destination		Requested Flight/Date		Amount of Insurance		INSURANCE – If carrier offers insurance, and such insurance is requested in accordance with the conditions thereof, indicate amount to be insured in figures in box marked “Amount of Insurance”.	
Handling Information							
Responsible Person: Dr. Smith Smithy, Labstreet 1, 4090 Labcity, US Tel. +01 34 5234593437, smith.g@email.com							SCI
No. of Pieces RCP	Gross Weight	kg lb	Rate Class Commodity Item No.	Chargeable Weight	Rate Charge	Total	Nature and Quantity of Goods (incl. Dimensions or Volume)
							BIOLOGICAL SUBSTANCES CATEGORY B UN 3373 Dry Ice, Class 9 UN1845, 1 x 3 Kg

8.3 Contractual arrangements between shipper and receiver

When shipping infectious substances, it is important to have a contractual arrangement in place between the shipper and the receiver. This arrangement should outline the responsibilities and obligations of both parties regarding the safe and secure transportation of the infectious substance. Some key elements that may be included in a contractual arrangement for the shipment of infectious substances can be regulated in a material transfer agreement (MTA) or mutually agreed terms (MAT).

Having a well-defined contractual arrangement can help ensure that the transportation of infectious substances is carried out safely and efficiently, and it can help mitigate the risks associated with transporting potentially hazardous materials.

Material Transfer Agreement

An MTA is a legal contract that governs the transfer of materials, such as infectious substances, between two parties. The purpose of an MTA is to define the terms and conditions of the transfer and to ensure that the recipient agrees to use the material only for the intended purposes.

In the context of transporting infectious substances, an MTA may be required if the substance is being transferred between different institutions – private or public, or between countries. An MTA outlines the terms and conditions under which the infectious substance is being transferred, including any restrictions on its use, handling, or disposal, which can play an important role for the legal control of any access and benefit-sharing legislation requirements.

Some key elements that may be included in an MTA for the transfer of infectious substances are the following.

- Description of material. This should include a detailed description of the infectious substance being transferred, including its scientific name, strain, and any special handling requirements.
- Purpose of transfer. This should specify the intended use of the infectious substance and any restrictions on its use or distribution.
- Intellectual property rights. This should address any intellectual property rights associated with the infectious substance, such as patents or copyrights.
- Liability and indemnification. This should specify the liability of both the sender and the recipient for any damage or loss related to the transfer of the infectious substance and include provisions for indemnification.
- Confidentiality. This should include provisions for maintaining the confidentiality of any information related to the infectious substance.
- Governing law and jurisdiction. This should specify the governing law and jurisdiction that will apply to the agreement.

Having an MTA in place can help ensure that the transfer of infectious substances is conducted safely and in compliance with applicable laws and regulations. It can also help protect the intellectual property rights of the sender and ensure that the infectious substance is used only for its intended purposes.

SECTION 9.

Incidents and accidents

9.1 Spill clean-up procedure

As part of the minimum information to be recorded on a DGTD, emergency response information should be available for relevant personnel in the event of a breach of packaging taking place. The following spill clean-up procedure has been adapted from information present in the *Laboratory biosafety manual*, 4th ed. (8), and represents an example of information that could be helpful for emergency response to an infectious substance spill.

The appropriate response in the event of exposure to any infectious substance is to wash or disinfect the affected area as soon as possible, regardless of the nature of the agent.

Even if an infectious substance comes into contact with broken skin, washing of the affected area with soap and water or with an antiseptic solution can reduce the risk of infection.

Medical advice should be obtained whenever a suspected exposure to an infectious substance resulting from a damaged package occurs.

The following procedure for clean-up can be used for spills of all infectious substances, including blood. The person must be trained in such a procedure before performing these steps.

1. Wear gloves and protecting clothing, including face and eye protection, if indicated.
2. Cover the spill with a cloth or paper towels to contain it.
3. Pour an appropriate disinfectant over the cloth or paper towels and the immediate surrounding area (5% bleach solutions are generally appropriate, but for spills on aircraft, quaternary ammonium disinfectants should be used).
4. Apply the disinfectant concentrically, beginning at the outer margin of the spill area and working towards the centre.
5. After about 30 minutes, clear away the materials. If there is broken glass or other sharps are involved, use a dustpan or a piece of stiff cardboard to collect the materials and deposit them into a puncture-resistant container for disposal.
6. Clean and disinfect the area of the spillage (if necessary, repeat steps 2–5).
7. Dispose of contaminated materials into a leak-proof, puncture-resistant waste disposal container.
8. After successful disinfection, report the incident to the competent authority and inform them that the site has been decontaminated.

Detailed information on disinfectants and their recommended use can be found in *Laboratory biosafety manual*, 4th ed. (8).

9.2 Reporting of accidents and incidents

Relevant national and international organizations should establish provisions for the reporting of accidents and incidents involving dangerous goods in transport. Reporting mechanisms for dangerous goods incidents and accidents involve a structured protocol to ensure timely and adequate response to minimize risks and manage the situation effectively. Note that precise procedures might vary depending on the country, mode of transportation (e.g. air, sea, road, or rail), and governing bodies. Immediate notification of relevant emergency services (e.g. fire, police, medical) to ensure a rapid and coordinated response to the situation is important.

There are two types of reporting: internal and obligatory due to regulatory requirements.

Internal reporting. Employees and stakeholders involved should immediately report the incident to designated internal entities within their organization, such as safety officers or incident management teams.

Regulatory reporting. Incidents involving dangerous goods often need to be reported to relevant regulatory bodies. This might include national transport safety boards or authorities (e.g. ADR-competent authority, aviation authority), environmental protection agencies, and occupational safety and health administrations. Regulatory bodies typically have specific reporting forms and channels (such as online portals or hotline numbers) to facilitate this process.

The specific steps and the detailed procedures might be more elaborated based on specific international conventions, national laws, and organizational policies related to the transportation of dangerous goods.

9.3 Legal and compliance

Shippers must adhere to legal requirements, which may include further reporting, compliance checks, and potential penalties. Where applicable, initiating and managing insurance claims is a crucial step. Findings from investigations should inform a review of existing protocols and, where necessary, lead to adjustments to prevent recurrence. Communications with external stakeholders, including customers, the general public, and possibly the media, to inform them about the incident and the steps being taken, shall be appropriately managed.

References

1. Recommendations on the transport of dangerous goods: model regulations, 23rd revised edition. New York, Geneva: United Nations; 2023 (<http://www.unece.org/trans/danger/danger.html>, accessed 11 October 2023).
2. Technical instructions for the safe transport of dangerous goods by air (Doc 9284), 2023–2024 edition. Montreal: International Civil Aviation Organization; 2023 (<https://www.icao.int/safety/DangerousGoods/Pages/Doc9284-Technical-Instructions.aspx>, accessed 11 October 2023).
3. Dangerous Goods Regulations. International Air Transport Association (<https://www.iata.org/en/publications/dgr/>, accessed 11 October 2023).
4. Regulation concerning the international carriage of dangerous goods by rail (RID). Berne: Intergovernmental Organisation for International Carriage by Rail; 2023 (http://otif.org/en/?page_id=1105, accessed 11 October 2023).
5. Directive 2008/68/EC of the European Parliament and of the Council of 24 September 2008 on the inland transport of dangerous goods (Council Directive 2008/68/EC) (<https://eur-lex.europa.eu/legal-content/EN/ALL/?uri=CELEX%3A32008L0068>, accessed 11 October 2023)
6. ADR, applicable as from 1 January 2023. About the ADR. Agreement concerning the international carriage of dangerous goods by road, Volumes I and II. New York and Geneva: United Nations; 2023 (<https://unece.org/transport/standards/transport/dangerous-goods/adr-2023-agreement-concerning-international-carriage>, accessed 11 October 2023).
7. IMDG code. International maritime dangerous goods code (inc. Amendment 41-22), 2022 edition. London: International Maritime Organization; 2022 (<https://www.imo.org/en/publications/Pages/IMDG%20Code.aspx>, accessed 11 October 2023).
8. Laboratory biosafety manual, fourth edition. Geneva: World Health Organization; 2020 (<https://www.who.int/publications/i/item/9789240011311>, accessed 11 October 2023).
9. List of Human and animal pathogens and toxins for export control. The Australia Group; 2022 (https://www.dfat.gov.au/publications/minisite/theaustraliagroupnet/site/en/human_animal_pathogens.html, accessed 12 October 2023).

Annex 1: International regulations and modal agreements

Please note that all websites are current as of 11 October 2023.

The UN dangerous goods website provides comprehensive detail concerning the UN *Recommendations on the Transport of Dangerous Goods*. It also provides links to the modal agencies. Visit: <http://www.unece.org/trans/danger/danger.html>.

The website below provides the full text of the *UN Model Recommendations (Rev. 23)*, which can be downloaded in PDF format. Visit: <https://unece.org/transport/dangerous-goods/un-model-regulations-rev-23>.

The website below provides the full text of the *Agreement concerning the International Carriage of Dangerous Goods by Road (ADR)* of 2023, including corrigendas. Visit: <https://unece.org/transport/standards/transport/dangerous-goods/adr-2023-agreement-concerning-international-carriage>.

Country specific information and competent authorities for the enforcement of the ADR can be found at <https://unece.org/transport/dangerous-goods/country-information-competent-authorities-notifications>.

Compliance with the below conventions, treaties, protocols, and guidelines is essential to ensure the facilitation, as well as safe and secure transport, of infectious substances, and to promote the sustainable use of genetic resources and biodiversity. Failure to comply can result in significant penalties and legal consequences, as well as hinder the transport of the infectious substance.

Convention on Biological Diversity

The Convention on Biological Diversity (CBD) is an international treaty that aims to conserve and sustainably use the world's biological diversity. The Cartagena Protocol on Biosafety is a supplementary agreement to the CBD that was established to address the safe handling, transport, and use of living modified organisms (LMOs) that may have adverse effects on the environment or human health.

The Access and Benefit-Sharing (ABS) and the Nagoya Protocol are two complementary legal instruments that were developed to ensure the fair and equitable sharing of benefits arising from the utilization of genetic resources. ABS legislation seeks to regulate access to genetic resources, while the Nagoya Protocol provides a framework for implementing ABS measures at the international level.

In relation to the transport of infectious substances, the Cartagena Protocol and ABS legislation may apply to the transport of genetically modified pathogens or microorganisms, which are subject to regulatory controls to ensure their safe handling, use, and transfer. The Nagoya Protocol may also be relevant to the transport of infectious substances that contain genetic resources obtained from unique sources, as it seeks to ensure the fair and equitable sharing of benefits arising from their utilization.

Convention on International Trade in Endangered Species of Wild Fauna and Flora

The Convention on International Trade in Endangered Species of Wild Fauna and Flora (CITES) is an international treaty that regulates the trade in certain species of wild animals and plants to ensure their survival. CITES aims to prevent the over-exploitation of endangered species and to promote their conservation and sustainable use.

In the context of the transport of infectious substances, CITES may be relevant to the transport of wildlife specimens that may be carriers of (potential) infectious diseases. CITES regulates the trade in certain wildlife species that may pose a risk to human health, such as primates or bats, which are known to carry disease causing pathogens.

Biological Weapons Convention and international Dual-Use Regimes

The Biological Weapons Convention (BWC) is an international treaty that prohibits the development, production, and stockpiling of biological weapons. The BWC aims to promote peaceful uses of biology and to prevent the use of biological agents as weapons of mass destruction.

The BWC is particularly relevant in this context, as it seeks to regulate the handling and transport of biological agents that could be weaponized. Due to the dual-use nature of some infectious substances, organizations and governments exercise extreme caution in their transport, handling, and usage. Special permits, risk assessments, and stringent security protocols are often required to ensure these materials are not diverted for malicious purposes. The BWC obligates signatory countries to enact measures that prevent the misuse of biological agents, which includes restrictions on the transport of infectious substances. Countries often adopt international accepted dual-use lists from international dual-use regimes (e.g. Australia Group) to harmonize their transport requirements with other countries. Therefore, in the realm of transporting infectious substances, compliance with BWC provisions becomes crucial, not just for biosafety but also for biosecurity reasons.

Basel Convention on the Control of Transboundary Movements of Hazardous Wastes

The Basel Convention on the Control of Transboundary Movements of Hazardous Wastes aims to regulate the international transport of hazardous materials to protect human health and the environment. Although the convention primarily focuses on waste materials, such as toxic chemicals, its scope can extend to infectious substances under certain conditions. If infectious substances are categorized as hazardous waste due to their potential for environmental harm or public health risks, they may fall under the Basel Convention's regulatory framework. In such cases, exporters are required to secure informed consent from the importing country before initiating transport. Both parties must also adhere to stringent packaging, labelling, and documentation requirements to ensure safe handling and disposal. The Convention advocates for the minimization of hazardous waste production and encourages the treatment and disposal of such waste as close to the source of generation as possible.

Terrestrial Animal Health Code

The World Organisation for Animal Health (WOAH, formerly known as OIE) has guidelines on the handling and transport of animal pathogens. These guidelines aim to prevent the spread of animal diseases and protect public health.

In relation to the transport of infectious substances, the OIE (now WOAH) guidelines may apply to the transport of animal pathogens that have the potential to cause disease in animals or humans. The guidelines require that animal pathogens and infectious substances be handled and transported in a way that minimizes the risk of spreading infectious diseases. Please find the modal agreements available for purchase below in Table 6, by accessing the following websites.

Table 6. Modal agreements available for purchase

Air	<p>ICAO Technical Instructions may be sought from: http://www.icao.int/safety/DangerousGoods/Pages/technical-instructions.aspx.</p> <p>Copies of state variations may be found at: http://www.icao.int/safety/DangerousGoods/Pages/StateVariationPage.aspx.</p>
Rail	<p>Regulations concerning the International Carriage of Dangerous Goods by Rail (RID) 2021 can be found at: http://otif.org/en/?page_id=1105.</p> <p>RID is primarily for the countries of Europe, North Africa and Middle East. There are a number of countries (mainly Eastern Europe and Asia that apply RID through the Organization for Cooperation of Railways (OSJD). Details of RID membership can be found at: http://otif.org/en/?page_id=51.</p>
Sea	<p>Please contact the International Maritime Organization at: https://www.imo.org/en/publications/Pages/IMDG%20Code.aspx.</p>
Post	<p>Please contact the Universal Postal Union at: https://www.upu.int/en/Contact-us.</p>

Annex 2: Special provisions

“Special Provisions” is a term used to describe certain circumstances or procedures that are not covered in standard regulations. These provisions are therefore needed to supplement or modify the original regulations to appropriately ship the dangerous goods to which it applies.

The following special provisions (as listed in the UN Model Regulations) may be applicable to some shipments of infectious substances. A together with a number in parentheses (e.g. A58) indicate an equivalent special provision number for shipments being carried by air (as listed in the ICAO Technical Instructions and IATA DGR). Air specific provisions are listed at the end.

144 (A58) An aqueous solution containing not more than 24% alcohol by volume is not subject to Dangerous Goods Regulations.

395 (A218) This entry must only be used for solid medical waste of Category A transported for disposal.

219 (A47) Genetically modified microorganisms (GMMOs) and genetically modified organisms (GMOs) packed and marked in accordance with packing instruction P904 (PI959) are not subject to any other requirements in these Regulations.

If GMMOs or GMOs meet the definition in chapter 2.6 of a toxic substance or an infectious substance and the criteria for inclusion in Division 6.1 or 6.2 the requirements (instructions) in these Regulations for transporting toxic substances or infectious substances apply.

223 (A3) If the chemical or physical properties of a substance covered by this description are such that when tested it does not meet the established defining criteria for the class or division listed in Column 3 of the Dangerous Goods List of chapter 3.2, or any other class or division, it is not subject to these Regulations (instructions).

-
- 276 (A27)** This includes any substance which is not covered by any of the other classes but which has narcotic, noxious or other properties such that, in the event of spillage or leakage on an aircraft, extreme annoyance or discomfort could be caused to crew members so as to prevent the correct performance of assigned duties.
- 279 (A113)** The substance is assigned to this classification or packing group based on human experience rather than the strict application of classification criteria set out in the Dangerous Goods Regulations (instructions).
- 318 (A140)** For the purposes of documentation, the proper shipping name shall be supplemented with the technical name (see 3.1.2.8). Technical names need not be shown on the package. When the infectious substances to be transported are unknown, but suspected of meeting the criteria for inclusion in category A and assignment to UN 2814 or UN 2900, the words “suspected category A infectious substance” shall be shown, in parentheses, following the proper shipping name on the transport document, but not on the outer packagings.

Air Transport specific special provisions applicable to some infectious substances shipments may include (the ICAO Technical Instructions):

- A2** This article or substance (applies to **UN3539 MEDICAL WASTE, CATEGORY A, AFFECTING HUMANS** or **MEDICAL WASTE, CATEGORY A, AFFECTING ANIMALS**) may be transported on cargo aircraft, only with the prior approval of the appropriate authority of the State of origin and the State of the operator under the written conditions established by those authorities.

Where States, other than the State of origin and the State of the operator, have lodged a variation advising that they require prior approval of shipments made under this Special Provision, approval must also be obtained from the States of transit, overflight and destination, as appropriate.

In each case, a copy of the document(s) of approval, showing the quantity limitations and the packing requirements, must accompany the consignment.

- A48** Packaging tests are not considered necessary.
- A81** The quantity limits shown in columns 11 and 13 do not apply to body parts, organs or whole bodies.

Note: *Blood, urine and other body fluids are not considered “body parts” for the purposes of this special provision.* Transport in accordance with this Special Provision must be noted on the Shipper’s Declaration for Dangerous Goods.

- A117** Wastes containing Category A infectious substances must be assigned to UN 2814 or UN 2900 or UN 3549, as applicable. Wastes transported under UN 3291 are wastes containing infectious substances in Category B or wastes that are reasonably believed to have a low probability of containing infectious substances. Decontaminated wastes, which previously contained infectious substances may be considered as not subject to these Instructions unless the criteria of another Class or Division are met.
- A151** When dry ice is used as a refrigerant for other than dangerous goods loaded in a unit load device or other type of pallet, the quantity limits per package shown in columns

11 and 13 of Table 3-1 for dry ice do not apply. In such case, the unit load device or other type of pallet must be identified to the operator and must allow the venting of the carbon dioxide gas to prevent a dangerous build-up of pressure.

A152 Insulated packagings conforming to the requirements of Packing Instruction 202 containing refrigerated liquid nitrogen fully absorbed in a porous material are not subject to Dangerous Goods Regulations provided the design of the insulated packaging would not allow the build-up of pressure within the container and would not permit the release of any refrigerated liquid nitrogen irrespective of the orientation of the insulated packaging and any outer packaging or overpack used is closed in a way that will not allow the build-up of pressure within that packaging or overpack. When used to contain substances not subject to this instructions, the words “not restricted” and the special provision number A152 must be provided on the air waybill when an air waybill is issued.

A180 Non-infectious specimens, such as specimens of mammals, birds, amphibians, reptiles, fish, insects and other invertebrates containing small quantities of UN 1170 (Ethanol), UN 1198 (Formaldehyde solution, flammable), UN 1987 (Alcohols, n.o.s.) or UN 1219 (Isopropanol) are not subject to this instructions provided the following packing and marking requirements are met:

- a. specimens are:
 1. wrapped in paper towel and/or cheesecloth moistened with alcohol or an alcohol solution and then placed in a plastic bag that is heat-sealed. Any free liquid in the bag must not exceed 30 mL; or
 2. placed in vials or other rigid containers with no more than 30 mL of alcohol or an alcohol solution;
- b. the prepared specimens are then placed in a plastic bag that is then heat-sealed;
- c. the bagged specimens are then placed inside another plastic bag with absorbent material then heat-sealed;
- d. the finished bag is then placed in a strong outer packaging with suitable cushioning material;
- e. the total quantity of flammable liquid per outer packaging must not exceed 1 litre; and
- f. the completed package is marked “scientific research specimens, not restricted. Special Provision A180 applies”.

The words “not restricted” and the special provision number A180 must be included in the description of the substance on the air waybill when an air waybill is issued.

A220 Packages containing COVID-19 vaccines accompanied by data loggers and/or cargo tracking devices containing lithium batteries are not subject to the marking and documentation requirements of Section II of Packing Instruction 967 or 970, as applicable. This same package configuration, when consigned without the COVID-19 pharmaceutical for the purpose of use or reuse, is also not subject to the marking and documentation requirements of Section II of Packing Instruction 967 or 970, as applicable, provided prior arrangements have been made with the operator.

Annex 3: Indicative list of infectious substances sub-classified as Category A

Indicative examples of infectious substances included in Category A in any form unless otherwise indicated	
UN number and Proper Shipping Name	Microorganism
UN 2814 Infectious substance, affecting humans	<i>Bacillus anthracis</i> (cultures only)
	<i>Brucella abortus</i> (cultures only)
	<i>Brucella melitensis</i> (cultures only)
	<i>Brucella suis</i> (cultures only)
	<i>Burkholderia mallei</i> – <i>Pseudomonas mallei</i> – Glanders (cultures only)
	<i>Burkholderia pseudomallei</i> – <i>Pseudomonas pseudomallei</i> (cultures only)
	<i>Chlamydia psittaci</i> – avian strains (cultures only)
	<i>Clostridium botulinum</i> (cultures only)
	<i>Coccidioides immitis</i> (cultures only)
	<i>Coxiella burnetii</i> (cultures only)
	Crimean-Congo haemorrhagic fever virus
	Dengue virus (cultures only)
	Eastern equine encephalitis virus (cultures only)
	<i>Escherichia coli</i> , verotoxigenic (cultures only)
	Ebola virus
	Flexal virus
	<i>Francisella tularensis</i> (cultures only)
	Guanarito virus
	Hantaan virus
	Hantaviruses causing haemorrhagic fever with renal syndrome
	Hendra virus
	Hepatitis B virus (cultures only)
	Herpes B virus (cultures only)
	Human immunodeficiency virus (cultures only)
	Highly pathogenic avian influenza virus (cultures only)
	Japanese Encephalitis virus (cultures only)
	Junin virus
	Kyasanur Forest disease virus
	Lassa virus
	Machupo virus
	Marburg virus
	Monkeypox virus (cultures only)
<i>Mycobacterium tuberculosis</i> (cultures only)	
Nipah virus	
Omsk haemorrhagic fever virus	
Poliovirus (cultures only)	
Rabies virus (cultures only)	

	<i>Rickettsia prowazekii</i> (cultures only)
	<i>Rickettsia rickettsii</i> (cultures only)
	Rift Valley fever virus (cultures only)
	Russian spring-summer encephalitis virus (cultures only)
	Sabia virus
	<i>Shigella dysenteriae type 1</i> (cultures only)
	Tick-borne encephalitis virus (cultures only)
	Variola virus
	Venezuelan equine encephalitis virus (cultures only)
	West Nile virus (cultures only)
	Yellow fever virus (cultures only)
	<i>Yersinia pestis</i> (cultures only)
UN 2900	African swine fever virus (cultures only)
infectious substance, affecting animals	Avian paramyxovirus Type 1 – Velogenic Newcastle disease virus (cultures only)
	Classical swine fever virus (cultures only)
	Foot and mouth disease virus (cultures only)
	Goatpox virus (cultures only)
	Lumpy skin disease virus (cultures only)
	<i>Mycoplasma mycoides</i> – Contagious bovine pleuropneumonia (cultures only)
	Peste des petits ruminants virus (cultures only)
	Rinderpest virus (cultures only)
	Sheep-pox virus (cultures only)
	Swine vesicular disease virus (cultures only)
	Vesicular stomatitis virus (cultures only)

Annex 4: Packing Instructions

The following annex provides the four packing instructions that may be relevant to the transport of infectious substances. Please note for Annex 4.1 – 4.3 (P620, P650 & P621) these are as provided in the UN Model Regulations. Additional requirements may exist in equivalent packing instructions in modal agreements, or other relevant conventions (e.g. ICAO-TI PI620, PI650 for air transport).

Annex 4.4 is as provided in the ICAO technical instructions. There is no equivalent for this packing instruction in the UN Model Regulations.

A4.1 Packing Instruction P620

P620	Packing instruction	P620
This instruction applies to UN 2814 and UN 2900.		
<p>The following packagings are authorized provided the special packing provisions described below are met: Packagings meeting the requirements of Chapter 6.3 and approved accordingly consisting of:</p> <p>A. Inner packagings comprising:</p> <ol style="list-style-type: none">1) leakproof primary receptacle(s);2) a leakproof secondary packaging;3) other than for solid infectious substances, an absorbent material in sufficient quantity to absorb the entire contents placed between the primary receptacle(s) and the secondary packaging; if multiple fragile primary receptacles are placed in a single secondary packaging, they shall be either individually wrapped or separated so as to prevent contact between them; <p>B. A rigid outer packaging.</p> <p>Drums (1A1, 1A2, 1B1, 1B2, 1N1, 1N2, 1H1, 1H2, 1D, 1G); Boxes (4A, 4B, 4N, 4C1, 4C2, 4D, 4F, 4G, 4H1, 4H2); Jerricans (3A1, 3A2, 3B1, 3B2, 3H1, 3H2).</p> <p>The smallest external dimension shall be not less than 100 mm (4 in).</p>		
Additional requirements:		
<p>A. Inner packagings containing infectious substances shall not be consolidated with inner packagings containing unrelated types of goods. Complete packages may be overpacked in accordance with the provisions of 1.2.1 and 5.1.2; such an overpack may contain dry ice. When dry ice or other refrigerants presenting a risk of asphyxiation are used as a coolant, the requirements of 5.5.3 shall apply.</p> <p>B. Other than for exceptional consignments, e.g. whole organs which require special packaging, the following additional requirements shall apply:</p> <ol style="list-style-type: none">1) Substances consigned at ambient temperatures or at a higher temperature. Primary receptacles shall be of glass, metal or plastics. Positive means of ensuring a leakproof seal shall be provided, e.g. a heat seal, a skirted stopper or a metal crimp seal. If screw caps are used, they shall be secured by positive means, e.g., tape, paraffin sealing tape or manufactured locking closure;2) Substances consigned refrigerated or frozen. Ice, dry ice or other refrigerant shall be placed around the secondary packaging(s) or alternatively in an overpack with one or more complete packages marked in accordance with 6.3.3. Interior supports shall be provided to secure secondary packaging(s) or packages in position after the ice or dry ice has dissipated. When dry ice or other refrigerants presenting a risk of asphyxiation are used as a coolant, the requirements of 5.5.3 shall apply. If ice is used, the outer packaging or overpack shall be leakproof. If dry ice is used, the outer packaging or overpack shall permit the release of carbon dioxide gas. The primary receptacle and the secondary packaging shall maintain their integrity at the temperature of the refrigerant used;		

3) Substances consigned in liquid nitrogen. When liquid nitrogen is used as a coolant, the requirements of 5.5.3 shall apply. Plastics primary receptacles capable of withstanding very low temperature shall be used. The secondary packaging shall also be capable of withstanding very low temperatures, and in most cases will need to be fitted over the primary receptacle individually. Provisions for the consignment of liquid nitrogen shall also be fulfilled. The primary receptacle and the secondary packaging shall maintain their integrity at the temperature of the liquid nitrogen;

4) Lyophilized substances may also be transported in primary receptacles that are flame-sealed glass ampoules or rubber-stoppered glass vials fitted with metal seals.

C. Whatever the intended temperature of the consignment, the primary receptacle or the secondary packaging shall be capable of withstanding without leakage an internal pressure producing a pressure differential of not less than 95 kPa and temperatures in the range -40 °C to +55 °C (-40 °F to +130 °F).

D. Other dangerous goods shall not be packed in the same packaging as Division 6.2 infectious substances unless they are necessary for maintaining the viability, stabilizing or preventing degradation or neutralizing the hazards of the infectious substances. A quantity of 30 ml or less of dangerous goods included in Classes 3 (flammable liquids), 8 (corrosive substances) or 9 (miscellaneous dangerous substances and articles, including environmentally hazardous substances) may be packed in each primary receptacle containing infectious substances. These small quantities of dangerous goods of Classes 3, 8 or 9 are not subject to any additional requirements of these Regulations when packed in accordance with this packing instruction.

E. Alternative packagings for the transport of animal material may be authorized by the competent authority in accordance with the provisions of 4.1.3.7.

Special packing provisions

Shippers of infectious substances shall ensure that packages are prepared in such a manner that they arrive at their destination in good condition and present no hazard to persons or animals during transport.

An itemized list of contents shall be enclosed between the secondary packaging and the outer packaging. When the infectious substances to be transported are unknown but suspected of meeting the criteria for inclusion in category A, the words "suspected category A infectious substance" shall be shown, in parenthesis, following the proper shipping name on the document inside the outer packaging.

Before an empty packaging is returned to the shipper, or sent elsewhere, it must be disinfected or sterilized to nullify any hazard and any label or mark indicating that it had contained an infectious substance must be removed or obliterated.

A4.2 Packing Instruction P650

P650

Packing instruction

P650

This packing instruction applies to UN3373

A. The packaging shall be of good quality, strong enough to withstand the shocks and loadings normally encountered during transport, including trans-shipment between cargo transport units and between transport units and warehouses as well as any removal from a pallet or overpack for subsequent manual or mechanical handling. Packagings shall be constructed and closed to prevent any loss of contents that might be caused under normal conditions of transport by vibration or by changes in temperature, humidity or pressure.

B. The packaging shall consist of at least three components:

- 1) a primary receptacle,
- 2) a secondary packaging, and
- 3) an outer packaging

of which either the secondary or the outer packaging shall be rigid.

C. Primary receptacles shall be packed in secondary packagings in such a way that, under normal conditions of transport, they cannot break, be punctured or leak their contents into the secondary packaging. Secondary packagings shall be secured in outer packagings with suitable cushioning material. Any leakage of the contents shall not compromise the integrity of the cushioning material or of the outer packaging.

D. For transport, the mark illustrated below must be displayed on the external surface of the outer packaging on a background of a contrasting colour and must be clearly visible and legible. The mark must be in the form of a square set at an angle of 45° (diamond-shaped) with each side having a length of at least 50 mm; the width of the line must be at least 2 mm and the letters and numbers must be at least 6 mm high. The entire mark must appear on one side of the package. The proper shipping name "BIOLOGICAL SUBSTANCE, CATEGORY B" in letters at least 6 mm high must be marked on the outer packaging adjacent to the diamond-shaped mark.



E. At least one surface of the outer packaging must have a minimum dimension of 100 mm × 100 mm.

F. The completed package shall be capable of withstanding a 1.2 m drop in any orientation without leakage from the primary receptacle(s), which shall remain protected by absorbent material, when required, in the secondary packaging.

NOTE: Capability may be demonstrated by testing, assessment or experience.

G. For liquid substances

- 1) The primary receptacle(s) shall be leakproof;
- 2) The secondary packaging shall be leakproof;
- 3) If multiple fragile primary receptacles are placed in a single secondary packaging, they shall be either individually wrapped or separated to prevent contact between them;
- 4) Absorbent material shall be placed between the primary receptacle(s) and the secondary packaging. The absorbent material shall be in quantity sufficient to absorb the entire contents of the primary receptacle(s) so that any release of the liquid substance will not compromise the integrity of the cushioning material or of the outer packaging; and
- 5) The primary receptacle or the secondary packaging shall be capable of withstanding, without leakage, an internal pressure of 95 kPa (0.95 bar).

NOTE: Capability may be demonstrated by testing, assessment or experience.

H. For solid substances

- 1) The primary receptacle(s) shall be siftproof;
- 2) The secondary packaging shall be siftproof;
- 3) If multiple fragile primary receptacles are placed in a single secondary packaging, they shall be either individually wrapped or separated to prevent contact between them; and
- 4) If there is any doubt as to whether or not residual liquid may be present in the primary receptacle during transport then a packaging suitable for liquids, including absorbent materials, shall be used.

- I. Refrigerated or frozen specimens: Ice, dry ice and liquid nitrogen
 - 1) When dry ice or liquid nitrogen is used as a coolant, the requirements of 5.5.3 shall apply. When used, ice shall be placed outside the secondary packagings or in the outer packaging or an overpack. Interior supports shall be provided to secure the secondary packagings in the original position. If ice is used, the outside packaging or overpack shall be leakproof; and
 - 2) The primary receptacle and the secondary packaging shall maintain their integrity at the temperature of the refrigerant used as well as the temperatures and the pressures which could result if refrigeration were lost.
- J. When packages are placed in an overpack, the package marks required by this packing instruction shall either be clearly visible or be reproduced on the outside of the overpack.
- K. Infectious substances assigned to UN 3373 which are packed and marked in accordance with this packing instruction are not subject to any other requirement in these Regulations.
- L. Clear instructions on filling and closing such packages shall be provided by packaging manufacturers and subsequent distributors to the consignor or to the person who prepares the package (e.g. patient) to enable the package to be correctly prepared for transport.
- M. Other dangerous goods must not be packed in the same packaging as Division 6.2 infectious substances unless they are necessary for maintaining the viability, stabilizing or preventing degradation or neutralizing the hazards of the infectious substances. A quantity of 30 ml or less of dangerous goods included in Classes 3 (flammable liquids), 8 (corrosives) or 9 (miscellaneous dangerous substances and articles, including environmentally hazardous substances) permitted as excepted quantities may be packed in each primary receptacle containing infectious substances. When these small quantities of dangerous goods are packed with infectious substances in accordance with this packing instruction no other requirements in these Regulations need be met.

Additional requirement:

Alternative packagings for the transport of animal material may be authorized by the competent authority in accordance with the provisions of 4.1.3.7.

A4.3 Packing Instruction P621

P621	Packing instruction	P621
------	---------------------	------

This packing instruction applies to UN3291.

The following packagings are authorized provided that the general provisions of 4.1.1 except 4.1.1.15 and 4.1.3 are met:

- A. Provided that there is sufficient absorbent material to absorb the entire amount of liquid present and the packaging is capable of retaining liquids:
 - Drums (1A1, 1A2, 1B1, 1B2, 1N1, 1N2, 1H1, 1H2, 1D, 1G);
 - Boxes (4A, 4B, 4N, 4C1, 4C2, 4D, 4F, 4G, 4H1, 4H2);
 - Jerricans (3A1, 3A2, 3B1, 3B2, 3H1, 3H2).
 Packagings shall conform to the packing group II performance level for solids.
- B. For packages containing larger quantities of liquid:
 - Drums (1A1, 1A2, 1B1, 1B2, 1N1, 1N2, 1H1, 1H2, 1D, 1G);
 - Jerricans (3A1, 3A2, 3B1, 3B2, 3H1, 3H2);
 - Composites (6HA1, 6HB1, 6HG1, 6HH1, 6HD1, 6HA2, 6HB2, 6HC, 6HD2, 6HG2, 6HH2, 6PA1, 6PB1, 6PG1, 6PD1, 6PH1, 6PH2, 6PA2, 6PB2, 6PC, 6PG2 or 6PD2).
 Packagings shall conform to the packing group II performance level for liquids.

Additional requirement:

Packagings intended to contain sharp objects such as broken glass and needles must be resistant to puncture and retain liquids under the performance test conditions in chapter 6.1.

A4.4 Packing Instruction PI954

PI954	Packing instruction	PI954
--------------	----------------------------	--------------

Packing Instruction 954

Passenger and cargo aircraft for UN 1845 only

General requirements

Part 4, Chapter 1 requirements must be met, including:

- A. Compatibility requirements
 - Substances must be compatible with their packagings as required by 4;1.1.3.
- B. Closure requirements
 - Closures must meet the requirements of 4;1.1.4.

<i>UN number and proper shipping name</i>	<i>Quantity — passenger</i>	<i>Quantity — cargo</i>
UN 1845 Carbon dioxide, solid or Dry ice	200 kg	200 kg

Additional packing requirements

In packages:

- A. must be packed in accordance with the general packing requirements of 4;1 and be in packaging designed and constructed to permit the release of carbon dioxide gas to prevent a build-up of pressure that could rupture the packaging;
- B. the shipper must make arrangements with the operator(s) for each shipment, to ensure that ventilation safety procedures are followed;
- C. the dangerous goods transport document requirements of 5;4 are not applicable provided alternative written documentation is provided describing the contents. The information on the document must be shown in the location provided for the description of the goods. Where an agreement exists with the operator, the shipper may provide the information by electronic data processing (EDP) or electronic data interchange (EDI) techniques. The information required is as follows and should be shown in the following order:
 - 1) UN 1845;
 - 2) **Carbon dioxide, solid or Dry ice**;
 - 3) the number of packages and the net quantity of dry ice in each package; and
- D. the net mass of the **Carbon dioxide, solid or Dry ice** must be marked on the outside of the package.

Dry ice may be shipped in a unit load device prepared by a single shipper provided that:

- A. the shipper has made prior arrangements with the operator;
- B. the unit load device must not contain dangerous goods other than UN 3373, Biological substance, Category B or ID 8000, Consumer commodity. Where the unit load device contains UN 3373 or ID 8000, the provisions of these Regulations that apply to those substances must be met in addition to the provisions set out in this packing instruction;
- C. the unit load device must allow the venting of the carbon dioxide gas to prevent a dangerous build-up of pressure (the marking requirement of 5.2 and the labelling requirements of 5.3 do not apply to the unit load device); and
- D. the shipper must provide the operator with written documentation or, where agreed with the operator, information by EDP or EDI techniques, stating the total quantity of the dry ice contained in the unit load device.

Annex 5: Additional regulations affecting the import and export of infectious substances

A5.1 Relevant regulations for export

Convention on International Trade in Endangered Species of Wild Fauna and Flora

If you are exporting infectious substances that are potentially CITES (Convention on International Trade in Endangered Species of Wild Fauna and Flora) material, you must obtain a CITES export permit from the relevant governmental authority responsible for wildlife conservation in your country. This usually involves proving that the material was legally obtained and that its export will not detrimentally affect the survival of the species in question. Both the exporting and importing countries usually need to issue permits for CITES-listed materials.

Nagoya Protocol and Access and Benefit-sharing legislation

If you are exporting infectious substances that are potentially covered under the Convention on Biological Diversity (CBD) and its subsequent Nagoya Protocol, you need to adhere to the regulations laid down by both your country's domestic laws and the CBD's international framework. The CBD aims to ensure the conservation of biological diversity, the sustainable use of its components, and the fair and equitable sharing of benefits arising from the use of genetic resources.

Specifically, you may need to obtain prior informed consent, as outlined in the Nagoya Protocol, from the country providing the genetic resources that yielded the infectious substances. This process typically involves negotiating a Material Transfer Agreement (MTA), which outlines how the benefits arising from the use of the genetic resources will be shared. The MTA must be compliant with the CBD's Access and Benefit-sharing (ABS) framework, designed to provide a fair distribution of benefits.

Domestically, an export permit from the governmental authority overseeing biodiversity is granted, given that all required documentation and information concerning the infectious substance, its intended use, and the recipient, is provided.

Cartagena Protocol on Biosafety

The Cartagena Protocol on Biosafety, as a supplementary Protocol to the CBD, regulates certain aspects of living modified organisms (LMOs). Shipments of LMOs are subject to rigorous labelling standards, and the associated shipping documents must minimally include details about the LMO's identity, as well as information about the sender and recipient.

The specific regulations for transporting LMOs vary depending on their intended application, whether it be for market distribution with marketing authorization, for controlled release in experiments, or for use in genetic engineering labs. Compliance with all pertinent legal mandates is obligatory throughout the shipping process.

Basel Convention on the Control of Transboundary Movements of Hazardous Wastes

From an exporting standpoint, the country is required to initiate the Prior Informed Consent (PIC) process by notifying the competent authorities in both the importing nation and any transit countries.

This involves providing specific details about the infectious waste, including its composition, volume, and intended method of disposal or treatment. Packaging and labelling must adhere to international guidelines, and the waste must be accompanied by a tracking document and the necessary export permits. Once the waste reaches its destination, the exporting country must ensure that it is managed in an environmentally sound manner, in line with the Convention's provisions.

A5.2 Relevant regulations for import

Dual-use and strategic goods regulation

When importing dual-use infectious substances, the process involves a stringent regulatory framework aimed at both biosafety and biosecurity. Usually, dual-use legislation aims at regulating the export of such goods and related knowledge, but in some countries dual-use goods are also strictly regulated from the import perspective. An essential part of the application process is a comprehensive risk assessment, which evaluates both biosafety and biosecurity risks. Once the application is submitted, agencies will review your application and may inspect your facilities to ensure compliance with safety and security measures. After approval, ensure that the imported material is securely packaged and labelled according to regulations. Post-import, adhere to any reporting and monitoring requirements and have an emergency response plan in place. Due to the sensitive nature of dual-use substances, strict security protocols must be implemented to prevent unauthorized access. Always consult with the relevant regulatory agencies to ensure full compliance with all legal requirements.

Convention on International Trade in Endangered Species of Wild Fauna and Flora

When importing infectious substances that may also contain material regulated by the Convention on International Trade in Endangered Species of Wild Fauna and Flora (CITES), a multifaceted approach is essential. Start by identifying the characteristics of the infectious substance and ascertain if it contains materials from species listed under CITES. Consult the national agencies responsible for both biosafety and CITES to determine the types of permits and certificates needed. A comprehensive risk assessment must be conducted, conforming to public health or biosecurity guidelines. Ensure that your shipping documentation clearly indicates the presence of both infectious substances and CITES-regulated material, if applicable. The packaging should meet the stringent requirements for both categories. Be prepared for inspections at both the point of export and import, as authorities will verify the necessary permits and correct packaging. Post-import, expect to adhere to any conditions or reporting requirements stipulated in your permits, and maintain detailed records for audit purposes. Consult with relevant agencies and legal experts to navigate the intricacies of this complex regulatory landscape.

Nagoya Protocol and Access and Benefit-sharing legislation

Importing infectious substances that also potentially fall under the scope of the Nagoya Protocol or other Access and Benefit-sharing (ABS) legislation adds an additional layer of complexity to an already challenging regulatory landscape. First, identify the biological material in question and determine if it originates from a country that is a Party to the Nagoya Protocol or other ABS agreements. If so, you'll need to establish whether Prior Informed Consent (PIC) and a Material Transfer Agreement (MTA) are necessary for accessing the genetic resources in question. These must be obtained from the competent national authority of the provider country.

Upon importation, be prepared for multiple layers of inspection, both to confirm that you've met biosafety requirements and to validate compliance with ABS provisions. Documentation will be essential throughout this process; keep meticulous records for auditing and adhere to any post-import reporting requirements. In many cases, non-compliance with ABS agreements can result in penalties and may affect future research collaborations. Always consult with experts familiar with both biosafety and ABS regulations to navigate this complex and often nuanced legal environment.

Cartagena Protocol on Biosafety

The Cartagena Protocol on Biosafety deals primarily with the transboundary movement of living modified organisms (LMOs), which include many GMOs (genetically modified organisms). Importing GMOs under the framework of the Cartagena Protocol involves several steps to ensure biosafety and compliance with international and national regulations. When importing GMOs in compliance with the Cartagena Protocol, you will first need to engage in an Advanced Informed Agreement (AIA) with the exporting country, including a detailed risk assessment. The importing nation's competent authority will then review the application and decide on approval. If approved, a permit specifying conditions will be issued. The imported GMOs must be clearly labeled and may require post-import monitoring. Throughout the process, it is crucial to also comply with any national regulations and to have an emergency response plan in place for accidental releases. Always consult with authorities in both exporting and importing countries to ensure full legal compliance.

Registration or notification of infectious substances

In some jurisdictions, the importation of infectious substances requires a specific registration or notification process, particularly if the material falls under the UN hazard classifications UN 2814, UN 2900, or UN 3373. The shipper and in some cases the receiver are responsible for registering these substances with the relevant authorities. A risk assessment may require laboratory analysis and must be documented. Following the risk assessment, an application for registration/notification is usually submitted to the governing agency, including details, such as the nature of the substance, its intended use, and the safety measures in place for its storage, handling, and transport. Once the registration is approved, the shipper receives a permit or identification number, which should accompany the material during shipment.

Basel Convention on the Control of Transboundary Movements of Hazardous Wastes

From the importing perspective, a country must confirm its ability to receive and appropriately manage infectious waste. This involves granting or denying the Prior Informed Consent (PIC) request, based on whether the country possesses the technical capacity and requisite permits to handle the waste. Once the shipment arrives, it is incumbent upon the importing nation to validate its receipt and confirm that the waste has been treated or disposed of in accordance with environmentally sound procedures. The importing country must also keep precise records of the transaction, as mandated by the Basel Convention.

Meticulous record-keeping is obligatory for a specified period to ensure compliance with international and domestic regulations, thereby safeguarding public health and environmental integrity.

For more information, contact:

World Health Organization
Emergency Preparedness (WPE)
Epidemic and Pandemic Preparedness and Prevention (EPP)
Biosecurity and Health Security Protection (BSP)

20 avenue Appia
1211 Geneva 27
Switzerland

E-mail: e-ISST@who.int

<https://www.who.int/activities/safeguarding-biosafety-and-biosecurity-in-laboratories>

