

# **ELECTRICAL ISSUES IN MINING**

V Fowler HMPIEEIM

All Island Seminar - October 2016

# Introduction



---

Going to talk about three electrical issues in mining which have harmed, or had the potential to harm.

- counterfeiting/substandard equipment
- variable speed drive risks
- arc flash risks

# The link - Asset Integrity



---

Asset lifecycle is in 4 stages;

- specification of plant and equipment and its **Procurement**
- initial integrity and its **Commissioning**
- through life integrity and its **Maintenance**
- end of life or extension to life and its **Decommissioning**

# Counterfeiting/Substandard

---



A growing problem ????



# Fake caplamps for use in potentially explosive atmospheres



Front view of KL2.5LM (B) & HL



Rear view of KL2.5LM (B)



Rear view of KL2.5LM (B) HL



CE Marked, marked as suitable for mines and label shows ATEX certificate detail and number of a UK notified body

# Atex assessment certificate



**1 EC TYPE-EXAMINATION CERTIFICATE**

2 Equipment intended for use in Potentially Explosive Atmospheres Directive 94/9/EC

3 Certificate Number: **Sira 11ATEX2273X** Issue: **0**

4 Equipment: **LED Cordless Mining Lamps  
KL2.5LM(A), KL2LM(A), KL1.4LM(A), KL1.4LM(B), and KL1.4LM(C)**

5 Applicant: **WUXI JIEBO Electrical Technology Co. Ltd**

6 Address: **35# Jingsheng Road  
Qianqiao Development Area  
Wuxi, Jiangsu  
China**

7 This equipment and any acceptable variation thereto is specified in the schedule to this certificate and the documents therein referred to.

8 Sira Certification Service, notified body number 0518 in accordance with Article 9 of Directive 94/9/EC of 23 March 1994, certifies that this equipment has been found to comply with the Essential Health and Safety Requirements relating to the design and construction of equipment intended for use in potentially explosive atmospheres given in Annex II to the Directive.

The examination and test results are recorded in the confidential reports listed in Section 14.2.

9 Compliance with the Essential Health and Safety Requirements, with the exception of those listed in the schedule to this certificate, has been assured by compliance with the following documents:  
EN 60079-0:2006 EN 60079-11:2007  
EN 60079-0:2009 (used for guidance in respect of marking)

10 If the sign 'X' is placed after the certificate number, it indicates that the equipment is subject to special conditions for safe use specified in the schedule to this certificate.

11 This EC type-examination certificate relates only to the design and construction of the specified equipment. If applicable, further requirements of this Directive apply to the manufacture and supply of this equipment.

12 The marking of the equipment shall include the following:  
 I M1  
Ex ia I Ma

  
C Ellaby  
Deputy Certification Manager

Project Number 22962

This certificate and its schedules may only be reproduced in its entirety and without change.

Form 9400 Issue 2 Page 1 of 2

**Sira Certification Service**  
Rake Lane, Eccleston, Chester, CH4 9JN, England  
Tel: +44 (0) 1244 670900  
Fax: +44 (0) 1244 681330  
Email: [info@siracertification.com](mailto:info@siracertification.com)  
Web: [www.siracertification.com](http://www.siracertification.com)

**1 EC TYPE-EXAMINATION CERTIFICATE**

2 Equipment intended for use in Potentially Explosive Atmospheres Directive 94/9/EC

3 Certificate Number: **Sira 11ATEX2273X** Issue: **0**

4 Equipment: **LED Cordless Mining Lamps  
KL2.5LM(A), KL2LM(A)HL, KL1.4LM(A), KL2.5LM(B), and KL2.5LM(B)HL**

5 Applicant: **WUXI JIEBO Electrical Technology Co. Ltd**

6 Address: **35# Jingsheng Road  
Qianqiao Development Area  
Wuxi, Jiangsu  
China**

7 This equipment and any acceptable variation thereto is specified in the schedule to this certificate and the documents therein referred to.

8 Sira Certification Service, notified body number 0518 in accordance with Article 9 of Directive 94/9/EC of 23 March 1994, certifies that this equipment has been found to comply with the Essential Health and Safety Requirements relating to the design and construction of equipment intended for use in potentially explosive atmospheres given in Annex II to the Directive.

The examination and test results are recorded in the confidential reports listed in Section 14.2.

9 Compliance with the Essential Health and Safety Requirements, with the exception of those listed in the schedule to this certificate, has been assured by compliance with the following documents:  
EN 60079-0:2006 EN 60079-11:2007  
EN 60079-0:2009 (used for guidance in respect of marking)

10 If the sign 'X' is placed after the certificate number, it indicates that the equipment is subject to special conditions for safe use specified in the schedule to this certificate.

11 This EC type-examination certificate relates only to the design and construction of the specified equipment. If applicable, further requirements of this Directive apply to the manufacture and supply of this equipment.

12 The marking of the equipment shall include the following:  
 I M1  
Ex ia I Ma

  
C Ellaby  
Deputy Certification Manager

Project Number 22962

This certificate and its schedules may only be reproduced in its entirety and without change.

Form 9400 Issue 2

**Sira Certification Service**  
Rake Lane, Eccleston, Chester, CH4 9JN, England  
Tel: +44 (0) 1244 670900  
Fax: +44 (0) 1244 681330  
Email: [info@siracertification.com](mailto:info@siracertification.com)  
Web: [www.siracertification.com](http://www.siracertification.com)

## Certificate detail

---

- SIRA assessment for lamp types
  - KL2.5LM(A), KL2LM(A), KL1.4LM(A),  
KL1.4LM(B) and KL1.4LM(C)
- Faked certificate
  - KL2.5LM(A) ✓ KL1.4LM(A) ✓
  - KL2LM(A) HL ✗
  - KL2.5LM(B) ✗
  - KL2.5LM(B) HL ✗

# The tip of the iceberg?



**COUNTERFEIT KILLS**  
**BE SAFE**  
DON'T ELECTROCUTE YOUR CUSTOMERS



The Electrical Installation Industry Charter

It's YOUR responsibility... only buy genuine quality electrical products... NOT counterfeits...  
**Blow the whistle.**  
Report counterfeit and non-complying electrical products to:  
[www.counterfeit-kills.com](http://www.counterfeit-kills.com)

EDA members sell only genuine products



News story  
**Report on counterfeiting and copyright piracy summit published**  
From:  
[Intellectual Property Office](#) and [The Rt Hon Dr Vince Cable MP](#)  
First published:  
1 October 2014  
Part of:  
[Business and enterprise](#)



**Big brands get ready to fight counterfeit goods**



Major manufacturers are preparing to combat the growing problem of counterfeit goods, which are estimated to cost the global economy billions of dollars each year.

The article discusses the challenges faced by brands in identifying and removing counterfeit products from the market, and the role of governments and industry groups in addressing the issue.





# Variable speed drives

---



## Benefits

- Eliminate fluid couplings/fire risks
- Soft start
- Energy saving
- Reduced wear and tear

# Variable speed drives

---



## Problems

- reduced motor speed can lead to overheating insulation failure and fire from ineffective cooling
- issues with bearings
- raised potentials/electric shock risks
- harmonics/insulation failures

# Basic Inverter

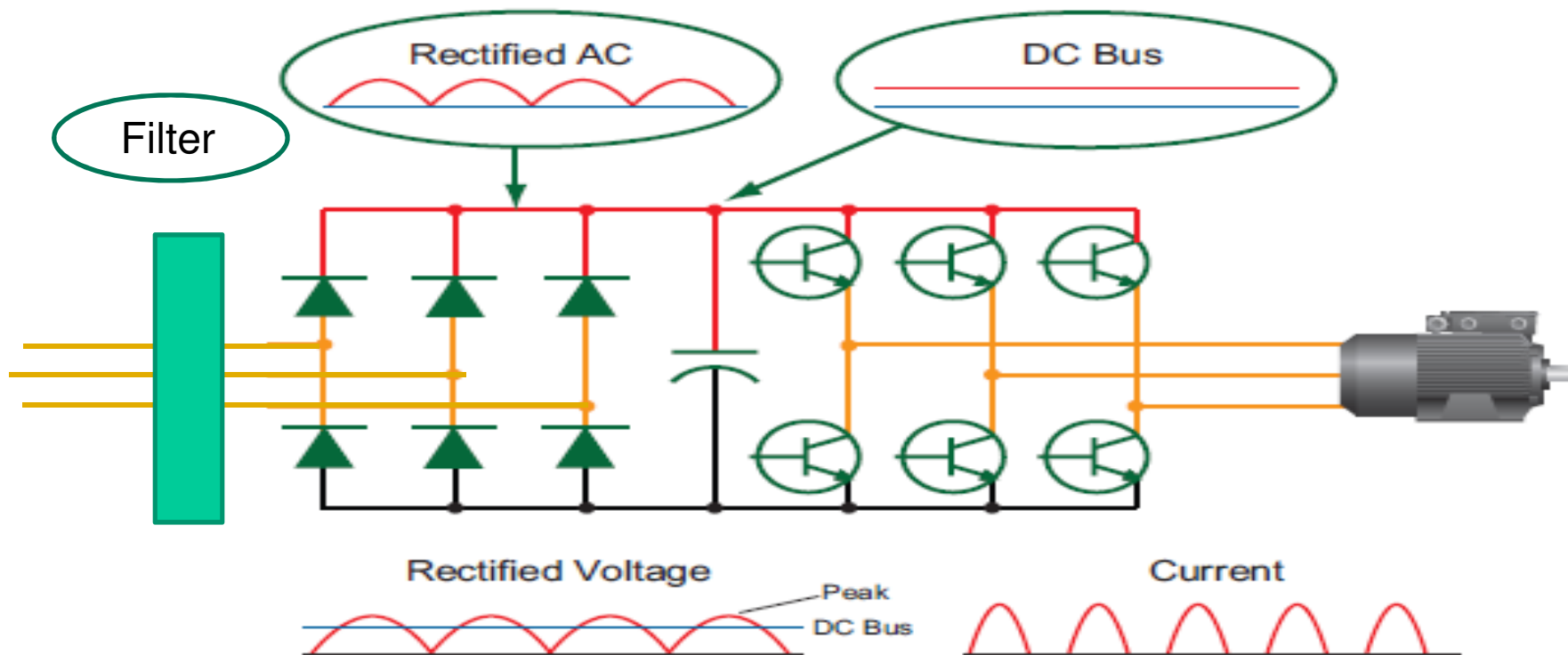

# Basic Inverter

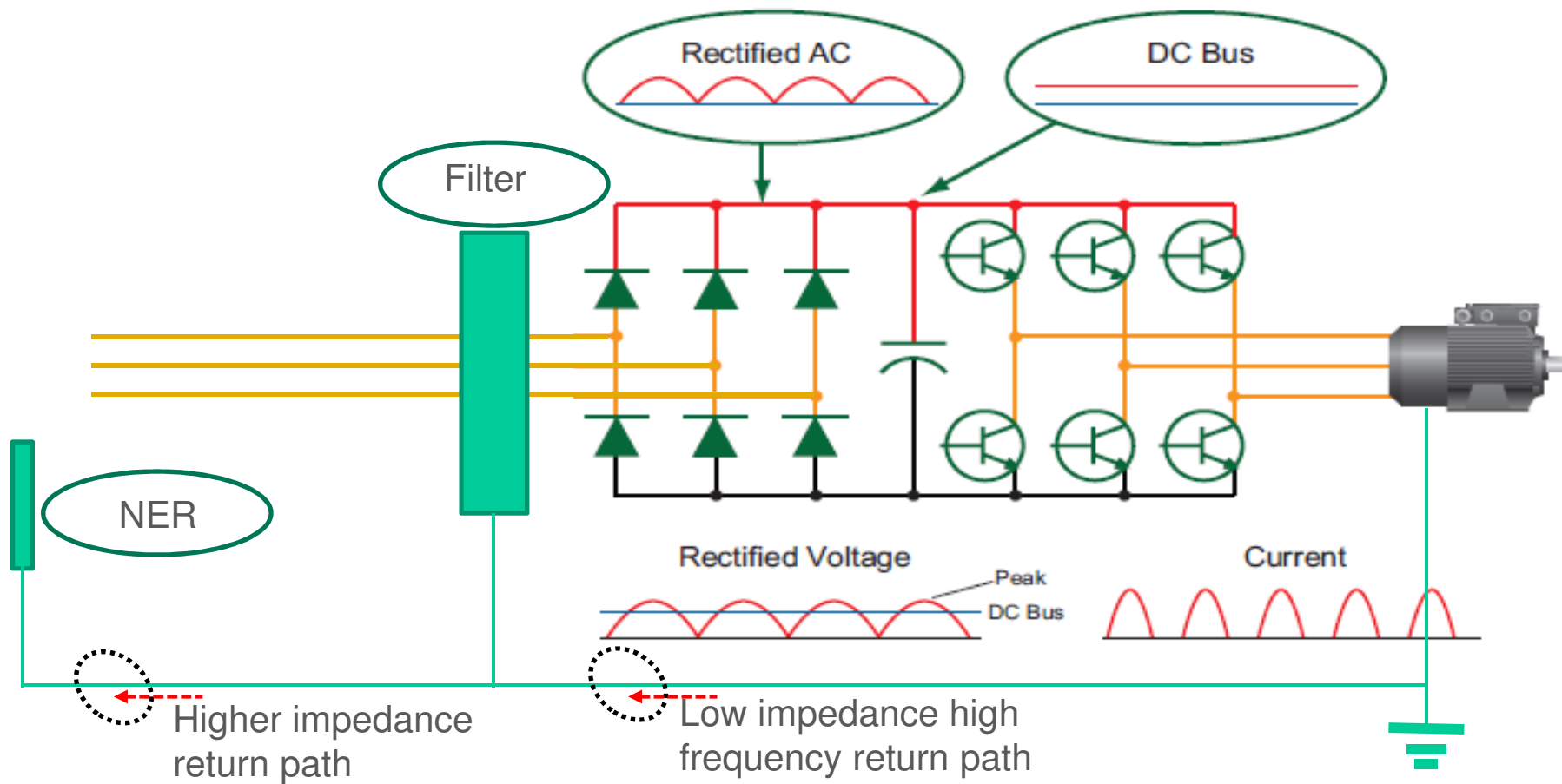

# Basic Invertor

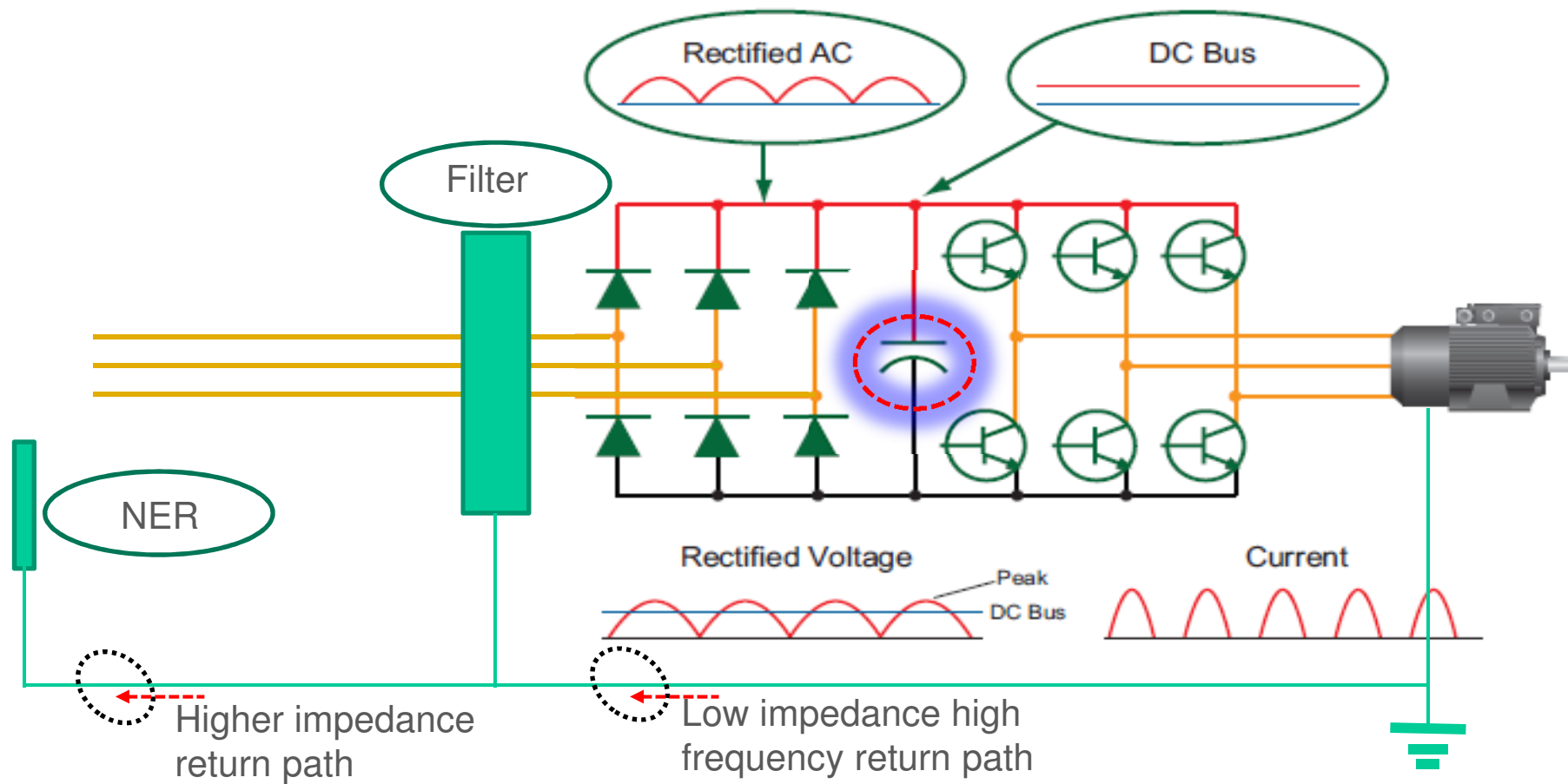

# Arc flash



---

## Arc Flash what it is

- where can it be present
- how can it be determined
- how to control the risks

# Arc flash

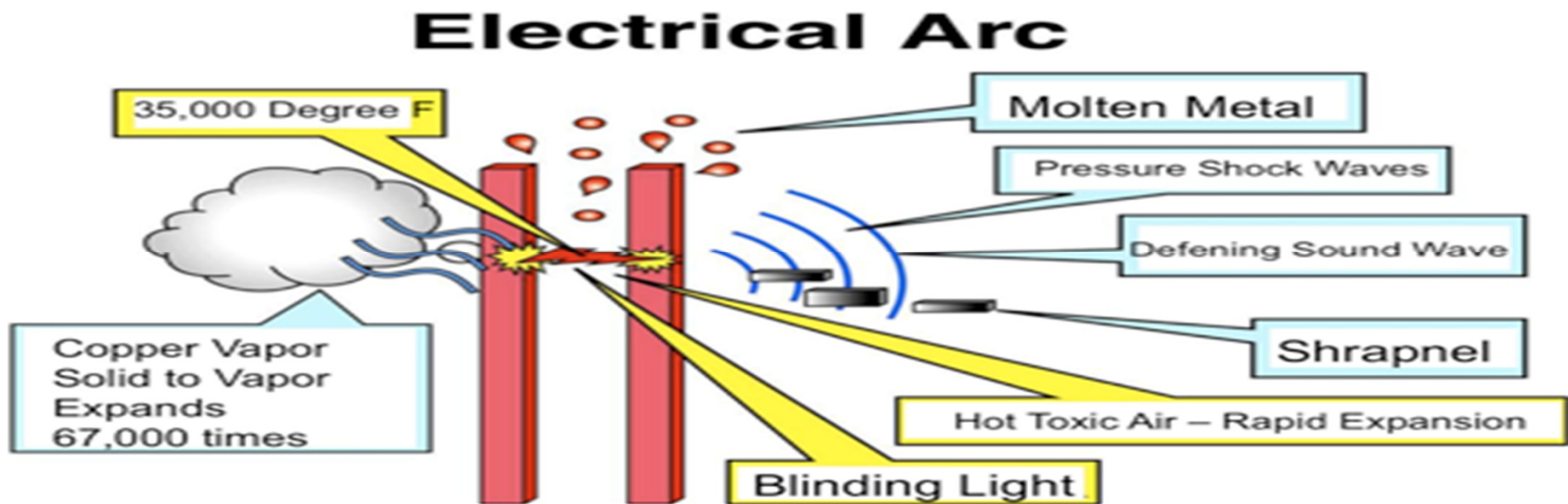

Arc Flash is the result of a rapid release of energy due to an arcing fault between a phase bus bar and another phase bus bar, neutral or earth. During an arc fault the air is the conductor

# Arc Flash – Slow Motion



- 
- <https://www.youtube.com/watch?v=P35HRYHFz7c>



# Arc Flash - when is it present?

---



Arcs are produced when load bearing contacts are opened or closed, when any live phases are shorted together and when any live phase is connected to earth or neutral – so why don't they produce effects like those just seen

Due to the level of energy available – systems where the energy isn't enough, or there is some form of current limitation – known as the fault level.

# Arc flash calculations

---

Establish energy levels – many free software tools are available, input elements include

- available energy based on supply
- fault clearance from protections
- working distance (Proximity to fault)

= answers in **XX** cal/cm<sup>2</sup>

# Determining the energy available

---



- energy exposure to a worker in calories per square centimeter.
- risk high enough - then consider alternatives
- Arc-rated flame resistant clothing and other PPE shall be used by the worker based upon the incident energy exposure
- overreggging may not be appropriate

# Controlling risks - hierarchy

---



Eliminate



Substitute

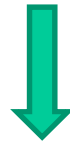

Reduce inventory



Engineering controls

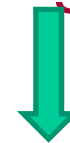

PPE

# Arrangements

---



- determine where Arc Flash potential exists
- post notices to warn of dangers
- inform, instruct and check competencies for all who operate equipment
- eliminate switching live wherever possible if arc flash risk is present
- new equipment specify Arc Flash protection built in
- last resort use PPE

# Summary

---



## Areas covered

- Counterfeiting/substandard
- Variable Speed Drives/benefits and concerns
- Arc flash hazards

The link to all these issues - Failure of asset integrity arrangements.

Have you got it adequately covered?



---

# Questions?

Contact V Fowler at

[vincent.fowler@hse.gov.uk](mailto:vincent.fowler@hse.gov.uk)